

# **TEC***gt200*

*DIRECT MANAGEMENT SYSTEM*



***ELECTRO*****MOTIVE**  
*ENGINE CONTROLS*

**TECgt200**

**Product Installation Manual  
& User's Guide**

**v0.3**

Electromotive, Inc.  
9131 Centreville Road  
Manassas, VA 20110

703-331-0100  
703-331-0100 fax  
[support@electromotive.com](mailto:support@electromotive.com)

# Table of Contents

<b>1</b>	<b>Terms and Conditions</b>	<b>7</b>
1.1	ELECTROMOTIVE, INC. PRODUCT WARRANTY	7
<b>2</b>	<b>Forward</b>	<b>8</b>
2.1	Improvements of the TECgt200 over the TECgt	9
2.2	Fundamentals of the System	10
<b>3</b>	<b>Installing the Hardware</b>	<b>11</b>
3.1	Pre-Installation Checklist	11
3.2	Mounting the Main Computer and DFU	12
3.3	Trigger Wheel and Sensor Installation	13
3.3.1	Crankshaft Trigger Installation for 60(-2) Tooth Wheel	14
3.3.2	Hall Effect or Magnetic Crank Sensors	14
3.3.3	Crank Sensor Installation	15
3.3.4	Wiring a Magnetic Trigger Sensor	16
3.3.5	Verifying Trigger Wheel Timing	17
3.3.6	Camshaft- & Distributor-Mounted Trigger Setups	19
3.3.7	Full Sequential Applications – Cam Synchronization	19
3.3.8	TDC Tooth Setup Software Adjustment Parameters	21
<b>4</b>	<b>Wiring the System</b>	<b>24</b>
4.1	Introduction	24
4.1.1	Suggestions on Crimp Terminals	24
4.2	Wiring ECU & Main Power	25
4.2.1	Power Harness Installation	25
4.3	Wiring the Fuel Injectors	26
4.3.1	High vs. Low Impedance Injectors	27
4.3.2	Injector Firing Schemes	28
4.3.3	Staged Injection	28
4.3.4	Phase-Sequential Injection	29
4.3.5	Full Sequential Injection	30
4.3.6	Rotary Engine Injection	31
4.3.7	Injector Channel Pinout	31
4.4	Wiring Ignition Coil Primary Sides	32
4.4.1	Introduction	32
4.4.2	Standard Direct Fire Units, DFU's	32
4.4.3	Wiring Standard DFU's Coils	32
4.4.4	Spark Plug Wiring High Voltage Side	34
4.5	Ignition Firing Order	37
4.5.1	Common Engine Sparkplug Wiring	37
4.6	Coil and Injector Firing Schemes	38
4.6.1	Injector and Coil Firing Patterns for EVEN-FIRE Engines	38
4.6.2	Injector and Coil Firing Patterns for ROTARY Engines	39
4.6.3	Injector and Coil Firing Patterns for 2-CYCLE Engines	39
4.6.4	Injector and Coil Firing Patterns for ODD-FIRE Engines	40
4.6.5	Examples of Typical Engine Setups	40
4.6.6	Common Firing Orders	43
4.6.7	How to find the TDC Event Order	44
4.6.8	TDC Tooth for DFU "2" needed for an Odd-Fire Engine:	44

4.6.9	Harley-Davidson Applications .....	44
4.6.10	Rotary Engines.....	44
4.6.11	Dual Plug Engines.....	45
4.7	Spark Plug Wire Selection .....	45
4.8	Spark Plug Selection .....	46
4.9	Driver on Coil Logic Driven Coils .....	48
<b>5</b>	<b>Wiring Sensors &amp; Other Inputs .....</b>	<b>49</b>
5.1	The Manifold Air Pressure (MAP) Sensor.....	49
5.1.1	MAP Sensor Data .....	50
5.2	Throttle Position Sensor .....	50
5.3	TPS Functionality and Wiring .....	51
5.4	Coolant Temperature Sensor .....	52
5.5	Manifold Air Temperature Sensor .....	54
5.6	The Exhaust Gas Oxygen Sensor .....	55
5.6.1	Mounting the EGO Sensor .....	55
5.6.2	Wiring the EGO Sensor.....	55
5.6.3	EGO Functionality .....	56
5.6.4	About One-Wire EGO Sensors .....	57
5.7	Wideband O2 Sensor .....	57
5.7.1	Wideband EGO Information and Installation Instructions.....	57
5.8	Secondary EGO sensor input.....	58
5.8.1	EGO FAQ's and Troubleshooting Tips:.....	58
5.9	Knock Sensor .....	59
5.10	Auxillary Temperature Sensor Input.....	60
5.11	General Purpose Inputs (GPI's) .....	60
5.11.1	Available General Purpose Input (GPI) Functons .....	61
5.11.2	Wiring the GPI's .....	62
<b>6</b>	<b>Wiring Outputs.....</b>	<b>64</b>
6.1	Idle Air Control Motor.....	64
6.1.1	Wiring a 2-wire IAC: .....	65
6.1.2	Wiring a 3-wire IAC: .....	66
6.2	Tachometer Output.....	68
6.3	Fuel Pump Relay Output .....	68
6.4	General Purpose Output (GPO) functions : .....	69
6.4.1	Outputs .....	70
6.4.2	Available GPO Functions .....	70
6.4.3	Wiring the GPO's: .....	71
<b>7</b>	<b>Communications Ports on the TECgt200.....</b>	<b>73</b>
7.1.1	PC communications, USB port.....	73
7.1.2	PC communications, RS232 Serial port .....	73
7.1.3	CAN bus serial port .....	73
<b>8</b>	<b>Tuning Guide.....</b>	<b>74</b>
8.1	Introduction.....	74
8.2	Adjusting the Timing Advance .....	74
8.3	Establishing Proper Starting Enrichments .....	75
8.4	Getting the Engine to Idle .....	76
8.5	Establishing Proper Acceleration Enrichments .....	76
8.6	Adjusting the VE Table .....	77

8.7	Using TPS/MAP Blend.....	78
8.8	Tuning for Cold Engines and Cold Weather .....	78
8.9	Tuning the Idle Air Control Motor.....	79
8.9.1	Configuring the New Electromotive Idle Speed Control .....	79
8.9.2	Idle Speed primer.....	80
8.9.3	Getting the IAC Started .....	80
8.9.4	Error Sensitivity .....	81
8.9.5	RPM Rate-of-Change Sensitivity.....	81
8.10	Tuning Tips: .....	82
8.10.1	Other tips: .....	82
<b>9</b>	<b>Fuel Injection.....</b>	<b>83</b>
9.1	Fuel Injector Pulse Width Derivation.....	83
9.1.1	TOG, IOT, and the Raw Fuel Curve .....	83
9.1.2	Load Percentage.....	83
9.1.3	Volumetric Efficiency Corrections.....	84
9.1.4	TPS/MAP Blend .....	84
9.1.5	Alpha-N Fuel Calculation .....	85
9.1.6	Other Corrections.....	85
9.1.7	Time on for One Gama (TOG) .....	85
9.1.8	Injector Offset Time (IOT) .....	89
9.1.9	Volumetric Efficiency Table Corrections.....	91
9.1.10	TPS/MAP Blend Corrections.....	92
9.1.11	Oxygen Sensor Corrections .....	94
9.1.12	Warm-Up Enrichments (Coolant Temperature-Based) .....	96
9.1.13	Manifold Air Temperature Enrichments.....	97
9.1.14	Throttle Position Sensor and MAP Enrichments .....	98
9.1.15	Starting Enrichments.....	99
9.1.16	Battery Voltage Compensation.....	100
9.1.17	Deceleration Fuel Cut-Off .....	101
9.1.18	Summary.....	102
<b>10</b>	<b>Fuel System .....</b>	<b>102</b>
10.1	Injector Sizing.....	103
10.2	Fuel Pump Selection .....	107
10.3	Fuel Pressure Regulator Selection.....	107
10.3.1	Absolute vs. Gage Pressure .....	108
10.3.2	Units of Measurement .....	108
<b>11</b>	<b>Diagnostics .....</b>	<b>110</b>
11.1	Trouble Codes from the LED's Mounted on the TECgt200 .....	110
11.2	Trouble Codes from the Check Engine Output .....	111
11.3	Trouble Code Descriptions.....	112
11.3.1	Using the Trouble Codes .....	113
11.3.2	Wiring the Check Engine Light.....	114
11.4	Tuning the Knock Control.....	115
11.5	Using the Injector Trims .....	115
11.6	Using the Ignition Advance Trims.....	115
11.7	Tuning the EGO Sensor.....	115
<b>12</b>	<b>Data logging with the TECgt200.....</b>	<b>116</b>
12.1	PC-Based Data logging.....	116

12.2	On-Board Data logging .....	117
<b>13</b>	<b>Rev Limiters .....</b>	<b>117</b>
13.1	Valet Mode Rev Limiter .....	117
13.2	Secondary Rev Limiter : .....	118
13.3	Primary Rev Limiter : .....	118
13.4	Zero degree advance .....	118
13.5	3-stage coil cut .....	118
13.6	Full coil cut .....	118
13.7	FUEL CONTROL REV LIMITING .....	119
13.7.1	No Fuel Cut .....	119
13.7.2	Fuel Cut .....	119
13.7.3	Progressive Fuel Cut .....	119
<b>14</b>	<b>Troubleshooting .....</b>	<b>120</b>
14.1.1	Air, Fuel, and Spark .....	120
14.2	Starting Problems .....	120
14.2.1	Air-Related Starting Problems .....	120
14.2.2	Fuel-Related Starting Problems .....	120
14.2.3	Spark-Related Starting Problems .....	121
14.3	Idling Problems .....	121
14.3.1	Air-Related Idling Problems .....	122
14.3.2	Fuel-Related Idling Problems .....	122
14.3.3	Spark-Related Idling Problems .....	122
14.4	Low-, Medium-, and High-Load Problems .....	122
14.4.1	Air-Related Load Problems .....	122
14.4.2	Fuel-Related Load Problems .....	122
14.4.3	Spark-Related Load Problems .....	123
<b>15</b>	<b>Appendix I. ECU Specifications .....</b>	<b>124</b>
15.1	OUTPUTS .....	124
15.1.1	Fuel Injector Drivers .....	124
15.1.2	Coil Outputs .....	124
15.1.3	Idle Air Control (IAC) Motor .....	124
15.1.4	General Purpose s (GPO's) .....	124
15.1.5	Fuel Pump Control .....	124
15.1.6	Tachometer Output .....	124
15.1.7	Check Engine Light Output .....	124
15.1.8	ECU Diagnostic Check engine Lamp .....	124
15.2	INPUTS .....	124
15.2.1	General Purpose Inputs (GPI's) .....	124
15.2.2	Engine Sensor Inputs .....	124
15.2.3	Angle Based Timing Control .....	125
15.2.4	Feedback Charging Control .....	125
15.3	Tuning Features .....	125
15.3.1	Ignition Timing Map .....	125
15.3.2	Fuel Map .....	125
15.3.3	Load Sensing – Three Options .....	125
15.3.4	Rev Limiters .....	125
15.3.5	On-Fly Tuning .....	126
15.3.6	Compensation Features .....	126
1.1	Supported Engine Configurations .....	126

15.3.7	4-Stroke .....	126
15.3.8	2-Stroke .....	126
15.3.9	Rotary .....	126
15.4	Data logging Features.....	126
15.4.1	Laptop Data logging .....	126
15.5	Physical Dimensions .....	127
15.6	Environmental Considerations .....	127
15.7	PC Requirements.....	127
<b>16</b>	<b>Appendix II. Trigger Wheel Availability .....</b>	<b>127</b>
<b>17</b>	<b>Appendix III. Secondary Coil Polarity for Redundant Ignition Applications .....</b>	<b>129</b>
<b>18</b>	<b>Software &amp; Firmware Support .....</b>	<b>130</b>
18.1.1	Software Coding Information.....	130
18.1.2	Firmware Coding Information .....	130
18.1.3	Software Upgrade Procedure.....	130
18.1.4	Firmware Upgrade Procedure.....	131
<b>19</b>	<b>Appendix IV. ECU Connector Pin Out List .....</b>	<b>132</b>
<b>20</b>	<b>Appendix V. ECU Connector Drawing .....</b>	<b>134</b>
<b>21</b>	<b>Appendix VII. Driver on Coil Schematic .....</b>	<b>135</b>
<b>22</b>	<b>Glossary of Terms .....</b>	<b>136</b>

# 1 Terms and Conditions

## 1.1 ELECTROMOTIVE, INC. PRODUCT WARRANTY

Products manufactured by Electromotive (XDi Ignitions and TEC ECUs) are built to last. Many of our products have been in service for multiple decades. Products sold, but not manufactured, by Electromotive are warranted as described under **Other Products and Parts We Sell**.

Should your product not be functioning properly during the warranty period, please first check **Tech Support** information available at [www.electromotive-inc.com](http://www.electromotive-inc.com) under the **Support** tab. You may find that the issue is due to something other than unit malfunction.

Our warranty period is 1 year effective January 1, 2017.

### **Product Warranty:**

With a **1 year limited warranty**, Electromotive offers, by far, one of the best warranties in the business on all new XDi and TEC units, for the original purchaser only, from the original purchase date. We warrant our products to be free of defects in materials and workmanship during the warranty period. The replacement product will, in turn, be warranted for 1 year from the date of replacement. Electromotive will pay for standard shipping to return the repaired/replacement unit to the customer, if a defect covered under warranty is found.

Note: At Electromotive's discretion, products that show evidence of tampering, abuse, accident damage, or other unusual wear and tear conditions may not be eligible for warranty coverage.

See details under **Warranty Exclusions**.

### **If You Need Warranty Service:**

Notify us at [support@electromotive-inc.com](mailto:support@electromotive-inc.com) or 703/ 331-0100 M-F 8:30 to 5:00 EST. Then, send (1) a note with a summary of the issues you are experiencing, (2) a copy of your sales receipt, and (3) the XDi or TEC unit. Ship to: Electromotive Repairs, 9131 Centreville Road, Manassas, VA 20110. **You must include the purchase receipt and it must clearly show name of the seller, date of purchase and purchase amount.**

Our policy is to provide a new or factory refurbished replacement unit rather than repair units under warranty, at our discretion. If the issue is something very minor, we may opt to repair rather than replace. Replacement products may include remanufactured or refurbished products or components.

**If your product is shown to be in complete working order when we receive it, you may be charged a small fee for handling and return shipping.**

### **Out-of-Warranty Product Repair**

Should your product be out of warranty, we offer factory diagnosis and repair services. There is a small fee for diagnosis and estimation of repair costs. Check with us for the current diagnosis fee. You will have options including (1) repair, (2) (if available) purchasing a refurbished unit, or (3) trading your old unit for a discount off a new unit. We strive to keep our repair times to within 5 business days, plus shipping days.

### **Other Products And Parts We Sell:**

We make every attempt to source products that live up to our quality standards. In the rare occasion that one of these products/parts fails within 90 days of purchase, return it to us along with a copy of your sales receipt and we will replace it if, at our discretion, the malfunction is not due to the same exclusions listed under **Warranty Exclusions**.

### **Warranty Exclusions:**

Any product, on which the serial number has been defaced, modified or removed or doesn't appear in the Electromotive serial number registry.

Damage, deterioration, or malfunction deemed to be from:

Accident, misuse, neglect, fire, water, lightning, or other acts of nature, unauthorized product modification, tampering, or failure to follow instructions supplied with the product/available for download from [www.electromotive-inc.com](http://www.electromotive-inc.com)

Repair or attempted repair by anyone not authorized by Electromotive.

Any damage due to shipment.

Removal or installation of the product.

Causes external to the product such as electric power fluctuations or failure

Use of supplies or parts not meeting Electromotive specifications.

Any other cause, which does not relate to a product defect.

### **Limitation of Implied Warranties:**

There are no warranties, expressed or implied, which extend beyond the description contained herein including the implied warranty of merchantability and fitness for a particular purpose.

### **Exclusion of Damages:**

Electromotive's liability is limited to the cost of repair or replacement of the product.

Electromotive shall not be liable for:

Any costs for removal, installation, tuning or set up of the unit before or after the malfunction.

Damage to other property caused by any defects in the product.

Damages based upon inconvenience, loss of use of the product, loss of time, loss of profits, loss of business opportunity, loss of goodwill, interference with business relationships, or other commercial loss, even if advised of their possibility of such damages.

Any other damages, whether incidental, consequential or otherwise

Any claim against the customer by another part.

Certain shipping charges.

## **2 Forward**

The **TECgt200** Total Engine Control system is the latest ignition system in the expanded line of ultra-high resolution engine management systems from the company that revolutionized engine management over twenty years ago. The **TECgt200** can be configured to control virtually any 1, 2, 3, 4, 6, 8 or 12 cylinder engine, as well as 1 or 2-rotor rotary engines, and dual plug 4 or 6 cylinders. The heart of the TEC series of engine management systems has always been a high-resolution ignition, which offers incredibly precise ignition timing even at the highest acceleration rates. The **TECgt200** continues this tradition; only what was once done with an analog ignition circuit is now done with a high-speed microprocessor. Direct Fire Units (DFU's) with twin-tower coils are available from Electromotive in 2- and 3-coil versions. Single tower coils are available as well. These DFU's are completely weather proof, and feature sealed electrical connectors. Additionally, the DFU's are impedance matched for optimum performance with our **TECgt200**.

The **TECgt200** has six dedicated fuel injector output channels. This allows up to 12 high impedance injectors to be driven. Staged injector firing is a built-in option on the **TECgt200** for most engine configurations. Sequential operation is also available through the use of a cam



position sensor but sequential operation is not available for the 8 cylinder engine option on the **TECgt200**.

There are Nine dedicated, user-definable, general-purpose inputs / outputs (GP I/O's) included with the **TECgt200** to make your high-tech engine setup a snap. The GP I/O's can be used to control anything from wastegates for turbo setups to simple electric radiator or intercooler fans. The possibilities are nearly limitless.

One of the GPI's has a frequency-based input capability, which can process data from wheel a speed sensor or similar device. The other GPI's are analog inputs only, and do not feature frequency-based capabilities. These channels can perform fuel trims, timing trims, and many other functions.

Besides the GP I/O's, several functions are built-in to the **TECgt200** that are quite useful on most applications. The following outputs are standard on the **TECgt200**:

- Tachometer (configurable to drive most modern tachs)
- Check Engine Light
- Fuel Pump Relay Ground (activated at appropriate times by the **TECgt200**)
- Idle Speed Motor control (stepper motor style or 2-wire style)

The **TECgt200** uses the following inputs to perform engine management:

- Crank Trigger
- Cam Trigger (optional)
- Manifold Air Pressure
- Coolant Temperature Sensor
- Manifold Air Temperature Sensor
- Throttle Position Sensor
- Knock Sensor (optional)
- Exhaust Gas Oxygen Sensor (O<sub>2</sub> sensor)

## 2.1 Improvements of the TECgt200 over the TECgt

The TECgt200 has the added features of:

1. Water resistant case and connector system
2. 6 high current ignition coil drivers to operate 12 cylinder or dual plug 6 cylinder engines.
3. 6 separate ignition coil logic outputs to operate up to 12 Driver On Coil (DOC) coils.
4. User selected fixed coil dwell time or standard coil current control.
5. General Purpose Inputs(GPI) separated from General Purpose Outputs(GPO)
6. On board USB port for direct connection to Laptop PCs.
7. Retained RS232 Serial port like older TECs with same functionality
8. New Second Oxygen sensor input
9. New Third temperature sensor input
10. High power Tach signal driver
11. Two range knock sensor sensitivity
12. Added 2 more GPO outputs
13. Dedicated road speed frequency input
14. Future Twin Variable Valve Timing cam input and output control

## 2.2 Fundamentals of the System

The goal behind Electromotive's Total Engine Control product line is to provide complete, high-resolution control of all functions of the modern engine, and to do so with a user-friendly interface. Consequently, the **TECgt200** is designed to easily control a huge number of complex engine management functions through the hands of a user who is new at the game.

### Engine Speed & Position = Crank Sensor...

What separates our engine management systems from those of our competitors is the fact that our products are all designed around an ultra high-resolution ignition. For this reason, we use a 60(-2) tooth crank trigger wheel to give the computer an extremely accurate engine position input. This is also the reason that we do not support any other types of trigger inputs. Take, for instance, the flying magnet trigger input used by some manufacturers: 8 cylinder engines have 4 magnets mounted to the crank trigger wheel. Our 60(-2) tooth trigger has *15 TIMES MORE RESOLUTION!* From a magnetic sensor aimed at the trigger wheel, the **TECgt200** receives its input for engine speed and position.

### Engine Load = MAP Sensor...

As nice as the 60(-2) tooth trigger wheel is for determining engine speed and position, more is necessary to perform ignition and fuel control; namely a load input. While many OEM's use Mass Airflow (MAF) sensors to determine the airflow (and thus the load) of an engine, Electromotive systems are designed around Manifold Air Pressure (MAP) sensors as the load-determining device. MAP sensors simply plug into the intake manifold of the engine (after the throttle), and are inherently easier to install than MAF sensors since they are not sensitive to vacuum leaks or engine airflow requirements. A 1-Bar MAP sensor is designed for naturally aspirated engines. A 2-Bar sensor is used for turbo/supercharged engines with up to 15psi (about 200kPa absolute) manifold boost. A 3-Bar sensor is good for up to 30psi (300kPa), while a 4-Bar is good for up to 45psi (400kPa). Choose the appropriate sensor for the application, and you are done.

### Ignition Advance Control...

Once the MAP sensor and crank sensor are installed, the **TECgt200** has inputs for RPM and load. Under steady-state conditions on a fully warmed-up engine, these are the only necessary inputs for the **TECgt200** to control the fuel and ignition curves. Control of the ignition advance curve is quite simple: there is a table of RPM vs. MAP in which the desired ignition advance angle is entered for every point. The table can be made in any size from 8x8 to 16x16 data points. Between each data point, there is a 256 point interpolation occurring. This keeps the advance curve from "stepping" from point-to-point. Additionally, it means that the engine can be tuned with only a few input numbers; some other systems on the market rely on the tedious input of hundreds of numbers to obtain an ignition advance curve that is still not as smooth between data points as ours.

### Fuel Injector Control...

Control of the fuel curve is very simple as well. When the user first sets up a calibration, the Tuning Wizard is generally used. The Wizard asks for the engine horsepower, peak RPM, number of injectors, and the amount of manifold boost. From these, a raw fuel curve is established. Most importantly, the User Adjustable Pulse Width (UAP/TOG) is established. UAP/TOG is the fuel injector pulse width when the MAP sensor reading is full-scale (wide-open throttle on a 1-Bar MAP sensor, 15psi boost on a 2-Bar sensor, etc.). The second variable that is established is the Injector Offset Time (IOT). IOT and TOG can be thought of as the idle adjustment screw and the main power jet of a carburetor, respectively. From these two numbers,

a **fundamental fuel curve** is established. However, the fundamental fuel curve only works on a thermodynamically linear engine. A thermodynamically linear engine would have a torque curve that is a flat horizontal line from idle to redline. In reality, engines stray from this straight line, sometimes dramatically, as in the case of motorcycle engines. To compensate for non-linear fuel consumptions, a Volumetric Efficiency (VE) table is included in the software. The VE table is based on RPM and MAP readings (like the Advance Table) to provide fuel injector pulse width offsets for various loads and engine speeds that stray from linear.

### Compensations...

Having a warmed-up engine running under steady-state conditions is all well and good, but in the real world, we must deal with cold weather starting, engine accelerations and decelerations, etc. For these scenarios, engines need fuel and spark *compensations*. The coolant temperature sensor (CLT) provides an input for the **TECgt200** to measure the engine temperature. Since cold engines need more fuel than hot engines, tables are provided in the software to allow fuel flow increases as a function of engine temperature. Other parameters related to the coolant temperature are cold starting (cranking) enrichments and throttle movement enrichments when cold. A Manifold air temperature (MAT) sensor is mounted in the intake tract to measure incoming air temperature. This reading is used to supply additional fuel for cold weather, or to take away some fuel on hot days. The throttle position sensor (TPS) is used for functions similar to the accelerator pump on a carburetor. Also, the TPS reading is used in the TPS-MAP Blend routine, which is very useful for multiple throttle setups and radically-cammed engines.

### Additional Features...

Once all the necessary input sensors are in place, and the software is tuned, the engine will run quite well. However, to further refine the control of the engine, a few additional features are included. The idle air control motor (IAC) is used to meter air into the engine at idle. This helps maintain a smooth idle, regardless of operating conditions. It can also be used to increase the idle for cold temperatures, or air conditioner activation. A fuel pump output is also included, which allows the user to turn on the fuel pump relay for a set amount of time when the ignition is turned on. This primes the fuel system, and powers the fuel pump once the engine is cranked and running. A tachometer output is included, which will drive most modern tachometers, and a check engine output is included to keep track of failed engine sensors. A host of other engine input and output options are included as well, and are outlined in other areas of this manual.

## 3 Installing the Hardware

### 3.1 Pre-Installation Checklist

To perform a complete **TECgt200** installation, the following items are required:

1. **TECgt200** Computer
2. DFU(s) or Driver on Coil Ignition Coils.
3. Resistor Core Spark Plug Wires (see notes on Spark Plug Wires)
4. **TECgt200** Wiring Harness w/ Power Harness
5. Windows-based PC-type Computer (see notes on Computer Requirements)
6. Serial Connector Cable (DB9) for PC or USB Cable
7. Crank Position Sensor (Magnetic Sensor)
8. 60 (-2) Tooth Crank Trigger Wheel or 120 (-4) Tooth Cam Trigger Wheel
9. Coolant Temperature Sensor (CLT)

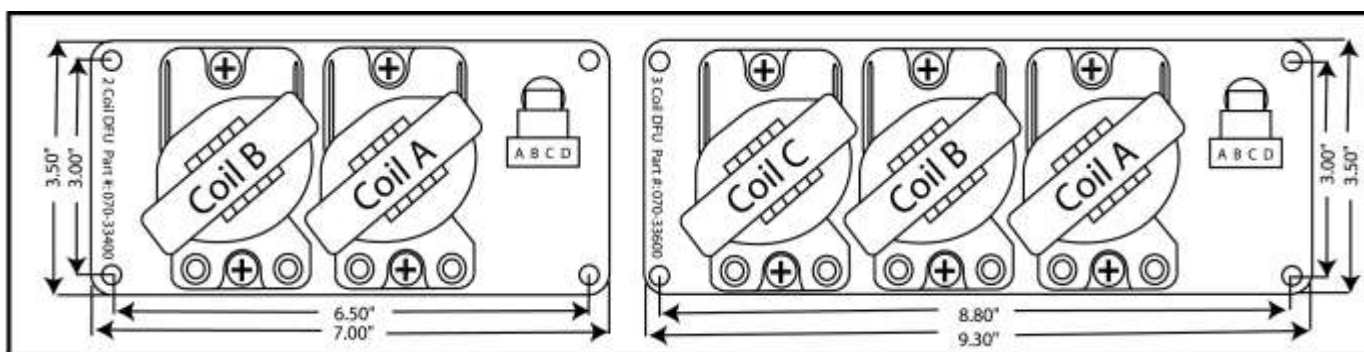
10. Manifold Air Temperature Sensor (MAT)
11. Manifold Air Pressure Sensor (MAP)
12. Throttle Position Sensor (TPS)
13. Exhaust Gas Oxygen Sensor (EGO)
14. Idle Air Control Motor (IAC)
15. Knock Sensor (KNK)
16. Fuel Rail(s) and Fuel Pressure Regulator (see notes on Fuel Pressure Regulator)
17. High Pressure Electric Fuel Pump (see notes on Fuel Pump)
18. Fuel Injectors (see notes on Fuel Injectors)
19. Fuel Injector Wiring Harness
20. Throttle
21. Wire Terminal Crimping Tool (available from Electromotive)
22. Shrink Tubing
23. Assorted Wire Crimp Terminals
24. Drill
25. ¼" Bolts for DFU(s) & **TECgt200** ECU
26. Soldering Gun

### 3.2 Mounting the Main Computer and DFU

For utmost reliability, install the **TECgt200** computer where temperatures will not exceed 150°F (65°C). The **TECgt200** computer should be installed in the passenger compartment of the vehicle where it will not be exposed to the elements. A good location is in the kick panel of a vehicle originally equipped with a factory ECU. As a second choice, the **TECgt200** may be mounted in an area that is partially exposed to the elements. It must not be mounted above or close to any exhaust or oil piping. A well vented area is recommended, particularly in engines utilizing most of the injector channels and operating at sustained high speeds. It should be noted that the **TECgt200** might get hot under prolonged high-rpm operation. As long as air is moving around the ECU, there is no risk of damage to the **TECgt200**; just be careful not to burn yourself on the unit! Secure the **TECgt200** ECU with four ¼" socket head cap screws. If the wiring harness goes through the firewall, a suitable grommet must be used to avoid chafing.

The DFU(s) can be placed nearly anywhere under the hood of the vehicle where the temperatures are below 250°F (120°C). Since they are entirely sealed, exposure to the elements is not an issue. The DFU Ground Wire **MUST** be installed to vehicle ground.

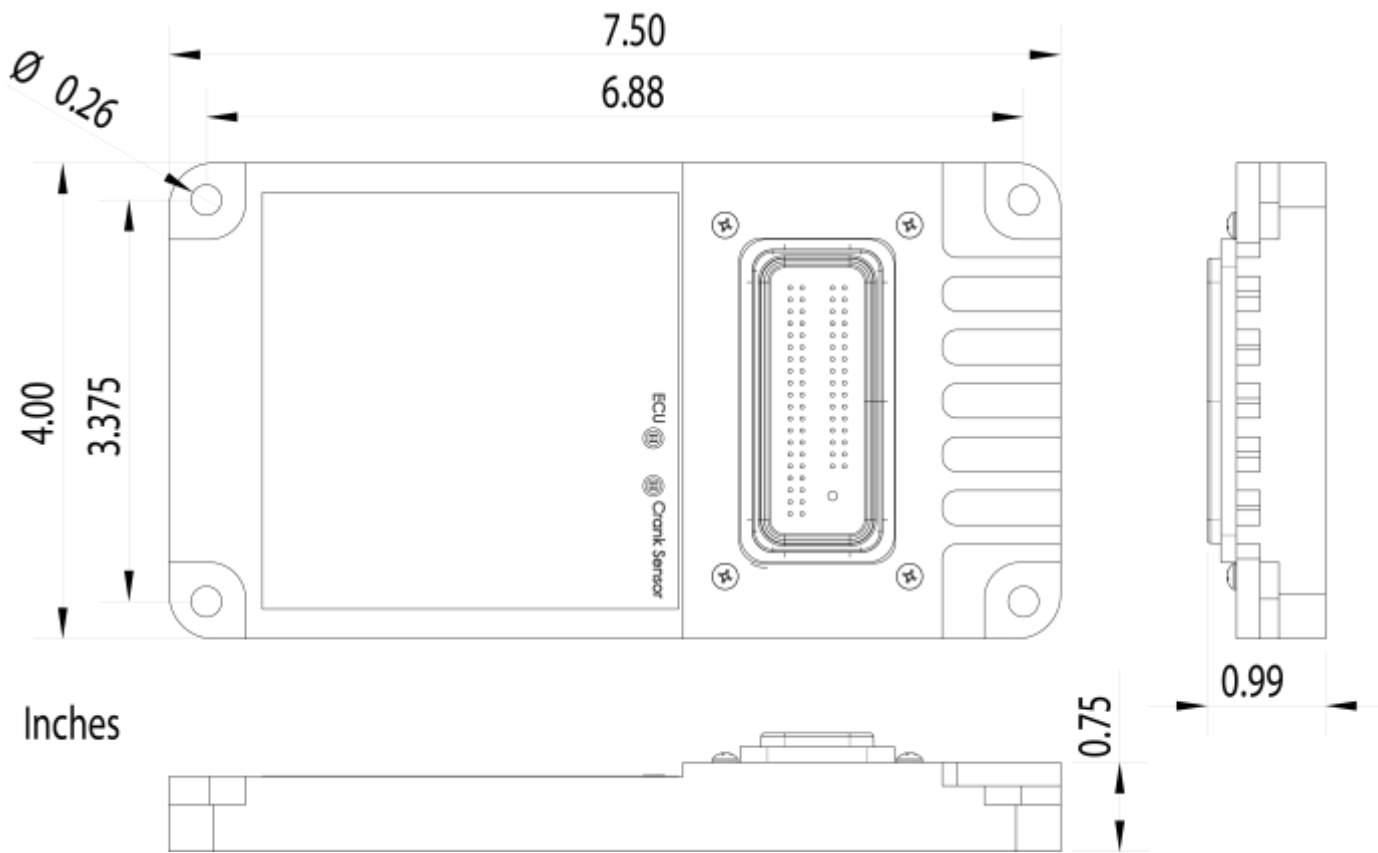
It is recommended that the ECU and DFU be separated by at least six inches for the purpose of reducing electrical noise in the ECU.



2-Coil DFU Dimensions

3-Coil DFU Dimensions

Figure 1. Electromotive Direct Fire Units



**Mounting bolt pattern is 3.375" x 6.88"**

Figure 2. TECgt200 ECU

### 3.3 Trigger Wheel and Sensor Installation

The foundation of the **TECgt200** ultra-high resolution ignition is the 60(-2) tooth trigger wheel. The trigger wheel is designed to give uncompromising timing accuracy at the highest engine acceleration rates. As such, Electromotive does not support other triggering systems, particularly those of the "flying magnet" variety. These systems can lead to vastly inaccurate spark timing, and can contribute to engine damage. For most applications, the 60(-2) tooth trigger wheel is mounted on the crankshaft damper or pulley. Some applications may warrant the use of a camshaft- or distributor-mounted trigger wheel. With this setup, a 120(-4) tooth trigger wheel is necessary, since the camshaft turns at half the speed of the crank.



### 3.3.1 Crankshaft Trigger Installation for 60(-2) Tooth Wheel

For a crankshaft-mounted trigger wheel setup, an appropriate place must be found to mount the wheel and trigger. Typically, the easiest place to mount a trigger wheel is on the harmonic damper or pulley. If it is mounted on a damper, it should be mounted on the inner hub rather than the outer dampening ring. The damper/pulley should be keyed to the crankshaft so that it cannot spin on the crankshaft, as this would cause an ignition timing error. When using a damper that has bolt-on pulleys, the trigger wheel can usually be mounted between the pulleys and the damper. However, the accessory pulleys will need to be shimmed out by 1/8" (the thickness of the trigger wheel). A variety of application-specific trigger wheels are available. See **Appendix II** for a listing of applications. Universal trigger wheels are also available in a variety of sizes, and are listed in **Appendix II** as well. Electromotive can custom-make trigger wheels in nearly any configuration for a one-time tooling fee.

To choose the proper size trigger wheel, find the diameter of the pulley or damper on which the wheel is to be mounted. The trigger wheel diameter should be about 1/2" larger than this diameter. It should also be noted that the trigger wheel should be at least 1/4" from any moving magnetic pieces, such as bolts or other fasteners, to avoid interference and false triggering. It is important that the trigger wheel be perfectly concentric with the crankshaft centerline. To achieve concentricity, a shallow cut can be machined in the front or rear face of the damper to create a centering ledge, and a hole can be created in the trigger wheel to match the ledge diameter. The trigger wheel can then be drilled to bolt it to the damper.

See **Table 1** below to determine the tolerances that must be maintained when mounting the trigger wheel. These tolerances may require the use of a lathe to true the trigger wheel with the crankshaft centerline, which can be accomplished by putting the entire damper/trigger wheel assembly on the lathe. Note that the maximum out-of-round is the distance between the lowest and highest teeth and the crank sensor. That is, if a feeler gauge is used between the sensor and the wheel to measure the out-of-round, the reading between the lowest and highest teeth should not exceed the guidelines in the table.

### 3.3.2 Hall Effect or Magnetic Crank Sensors

The TECgt200 can accept either a magnetic sensor or a Hall Effect sensor. Magnetic sensors can be used for all wheel diameters however, it is recommended to use a magnetic sensors when the Trigger wheel is less than 4 inches in diameter . Hall Effect sensors should not be used for trigger wheels less than 4 inches. Hall effect sensors are preferred because they have better noise rejection. However Hall Effect sensors require adding a +12V power lead to it. Electromotive can supply both Magnetic and Hall Effect sensors.

**Table 1:** Crank Trigger Specifications

Trigger Wheel Size	Air Gap	Maximum Out-of-Round
2.5"	0.025" max	0.002"
3.5"	0.035" max	0.003"
5"	0.050" max	0.005"
6"	0.060" max	0.006"
7.25"	0.070" max	0.007"
8.25"	0.080" max	0.008"

### 3.3.3 Crank Sensor Installation

When installing the crank sensor, an appropriate bracket must be made to aim the sensor at the trigger wheel. A good starting point for a magnetic sensor bracket is Electromotive part number 210-72003, which is our universal sensor bracket (**See Figure 3**). If this part is not used as a starting point, a custom bracket can easily be made. **The most important things to remember when fabricating a bracket are that it should be bolted directly to the engine block, away from rotating steel or magnetic pieces, and should be nonferrous (not**



**Figure 3.** Universal Crank Sensor Bracket

**attracted to magnets).** This will keep the sensor and trigger wheel vibrating together so the gap between the two always stays the same. Variations in sensor gap may cause erratic timing or false triggering of the ignition. (This is the reason for not mounting the trigger wheel to the outer ring of a harmonic damper.) As such, any custom magnetic sensor bracket should be very rigid. The sensor can be secured with either a set screw or a clamping arrangement, as long as the 1/2" sensor is utilized (part number 250-72218). If the smaller 3/8" sensor is used, a clamping arrangement should be employed rather than a setscrew, as the setscrews may crush the sensor. Hall effects sensors are only available in 1/2" diameter. **See Table 2** for the appropriate magnetic sensor/trigger wheel combinations.

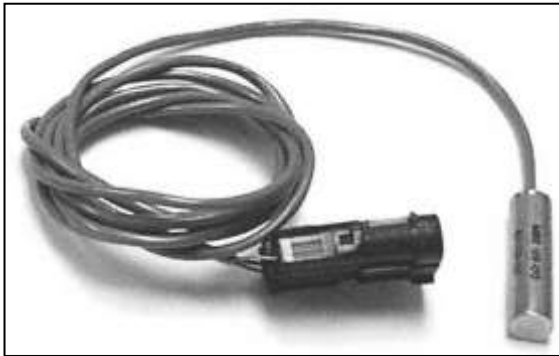
Once a sensor and trigger wheel are installed, they must be aligned such that the **TECgt200** computer knows where to locate Top Dead Center of the #1 cylinder (referred to as TDC #1). **Correct alignment necessitates that the center of the sensor must be aligned with the trailing edge of the 11<sup>th</sup> tooth after the two missing teeth when the engine is at TDC #1 (see the drawing at the end of this section).** Aligning the magnetic sensor with anything other than the 11<sup>th</sup> tooth will cause an ignition timing retard or advance, depending on the direction of the misalignment. Each tooth represents six degrees, so if the sensor is aligned with the trailing edge of the 12<sup>th</sup> tooth, the timing will be advanced by six degrees. Conversely, if the sensor is aligned with the trailing edge of the 10<sup>th</sup> tooth, the timing will be retarded by six degrees. In the event that the sensor is not aligned correctly, the WinTec software can be made to compensate by manipulating the Tooth Offset Parameter, as outlined in **the tuning section** of this manual.

#### **IMPORTANT NOTE :**

**Make sure that the Mag. Sensor harness is NOT routed near battery cables or other high current leads or devices such as cooling fans, starter or alternator. Coil wires, injector leads also should be avoided.**

**Table 2:** Magnetic crank sensor selection. Note: use a clamping arrangement for securing 3/8" sensors, rather than a setscrew. The 1/2" sensors can be secured with any clamping method.

	3/8" Diameter Chisel Point Sensor PN: 250-72212	1/2" Diameter Flat Tip Sensor PN: 255-72218	1/2" Diameter Flat Tip Hall Effect Sensor
All 120 (-4) Tooth 2-3/8" & 2-1/2"	X		
60 (-2) Tooth	X		
3-1/2" 60 (-2) Tooth (below 6000rpm)	X	X	
3-1/2" 60 (-2) Tooth (Above 6000rpm)	X	X	
Greater than 3-1/2" 60 (-2) Tooth wheels	X	X	X
1 tooth Cam Wheel			X



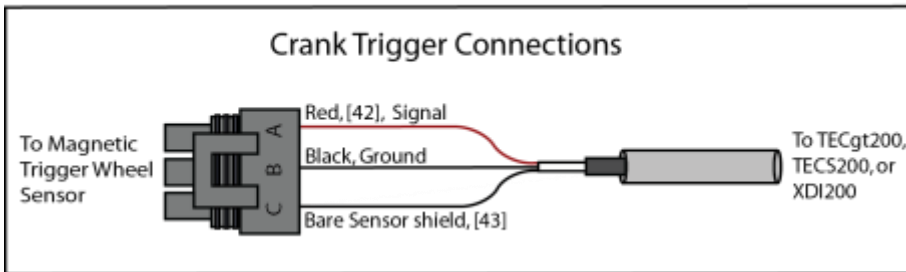
**Figure 4.** Electromotive 1/2" (12.7mm) crank sensor



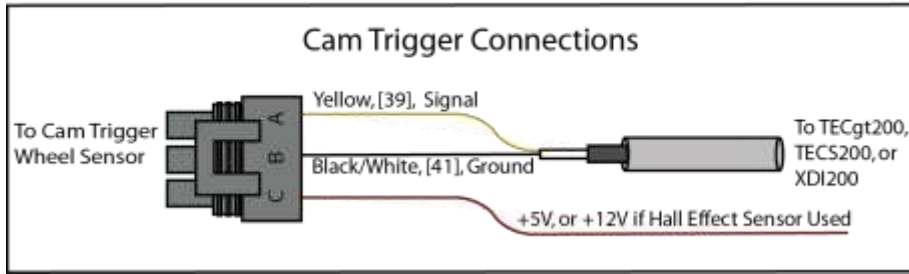
**Figure 5.** Electromotive 3/8" (9.53mm)

### 3.3.4 Wiring a Magnetic Trigger Sensor

The magnetic sensor has three wires. The red wire is the signal from the sensor, the black wire is the signal ground, and the bare wire is the shield. The harness has provisions for both a crank and a cam sensor. **The crank sensor cable must be used for all 60 (-2) or 120 (-4) tooth trigger wheel inputs.** It is not recommended to use a magnetic sensor on the cam trigger wheel.





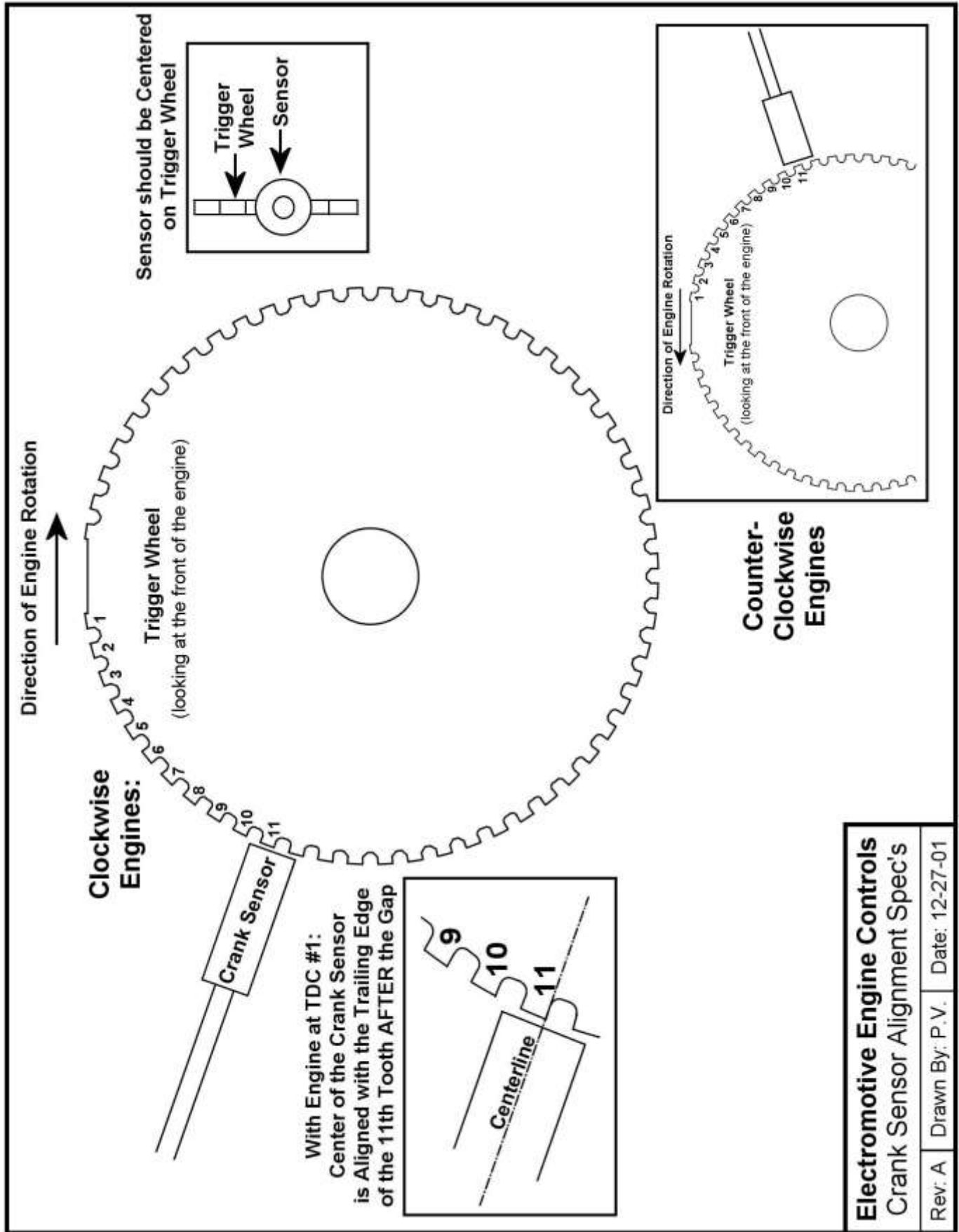


**Figure 6:** Wiring layout for crank and cam sensors. Note that the Cam Sensor is only used on full sequential applications. It is NOT used on applications using the 120(-4) tooth cam trigger wheel with no crank trigger. The wiring is the same if a Hall Effect sensor is used on the crankshaft wheel.

### 3.3.5 Verifying Trigger Wheel Timing

The most important step in the trigger wheel installation process is to check the ignition advance with a timing light. A timing indicator (pointer) should be attached to the engine block, and it should point at a line on the crankshaft pulley or trigger wheel when the engine is at TDC #1. When running the engine, verify that the timing value read by the timing light corresponds to the timing value in the software's engine monitor screen.

Use of a good-quality inductive timing light is recommended. DO NOT use a timing light that goes between the spark plug and spark plug wire with a clamp probe. Dial-Back inductive timing lights can be used, but will need to be dialed to DOUBLE the actual desired timing value due to the waste-spark firing of the DFU coils. They are fooled into thinking that the timing is twice as advanced as it actually is.



### 3.3.6 Camshaft- & Distributor-Mounted Trigger Setups

While crankshaft mounted triggers are preferred, it is sometimes easier to install a camshaft- or distributor-mounted trigger wheel. For these cases in which the trigger wheel is spinning at **half the engine speed**, a 120(-4) tooth trigger wheel is necessary. This wheel has two sets of two missing teeth, spaced 180 degrees apart. As such, the input to the **TECgt200** is identical to that of the crank-mounted 60(-2) tooth trigger wheel. Electromotive offers 120 (-4) tooth wheels in 3.25" and 2.75" diameters.

It is often easy to use an old distributor rotor to serve as the mount for a 120(-4) tooth trigger wheel. A simple nonferrous bracket would need to be fabricated to hold the sensor. The 3/8" chisel point sensor (PN: 250-72219) must be used on 120(-4) trigger wheels. As such, the bracket for the sensor should use a clamping arrangement rather than a setscrew to hold the magnetic sensor. **Just like the crank-mounted trigger, the distributor/cam-mounted triggers require the sensor to be aligned with the trailing edge of the 11<sup>th</sup> tooth after the two missing teeth when the engine is at TDC #1.** The same tolerances that apply to the crankshaft-mounted trigger wheels (**Table 1**) apply to the camshaft-mounted trigger wheels as well.

#### **A Note on Engines with High-Overlap Camshafts:**

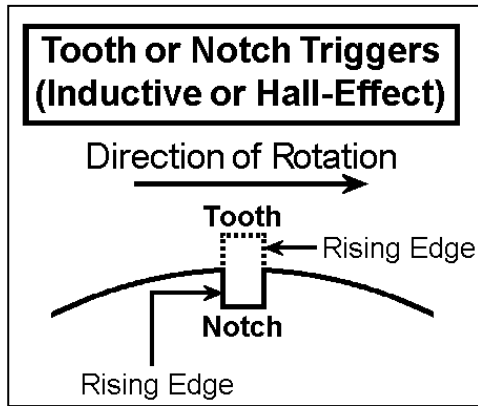
If your engine is equipped with a camshaft that has early intake valve openings or very long duration, you may experience backfiring through the throttle during starting. This is caused by the intake valves beginning to open on the exhaust stroke. Since the spark plugs fire on both the compression and the exhaust strokes, the spark on the exhaust stroke may cause unburned fuel in the intake manifold to ignite, resulting in a backfire.

To remedy this situation, advance the "mechanical" timing by manipulating the **DFU "A" Trigger Wheel TDC** Parameter. If your crank sensor is aligned with the 11<sup>th</sup> tooth of the trigger wheel at TDC #1, setting the Tooth Offset to a number LOWER than 11 will **add** mechanical advance. If the number "10" was set for the Tooth Offset, the mechanical timing would be **ADVANCED** by 6 degrees (6 degrees per tooth). This would require that you subtract 6 degrees from the values in your ignition advance table in WinTec to obtain your desired advance value. That is, the timing table will have to read 30 degrees in order for the engine to operate at 36 degrees advance. See **the Tuning Guide Section** for more details.

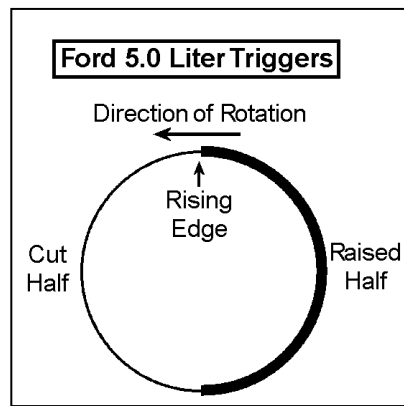
### 3.3.7 Full Sequential Applications – Cam Synchronization

When full sequential fuel operation is desired, a once-per-engine-cycle synchronization, or "sync," pulse must be received by the ECU. Typically, the sync pulse is generated by the installation of a 1-notch (or 1-tooth) trigger wheel onto the camshaft. A Hall effect sensor is used as a triggering method. With this method, the tooth must pass by the magnetic sensor between 180° and 6° before TDC Compression (not exhaust) of the number one cylinder. See **Figure 11** for installation details.

**The TECgt200 will only trigger off a rising voltage during the synchronization period (between 180° and 6° BTDC compression).** A rising edge occurs when the metal on the cam trigger wheel becomes closer to the sensor. See **Figures 8 and 9** for representative examples and different cam trigger wheel designs, and their rising edge location.



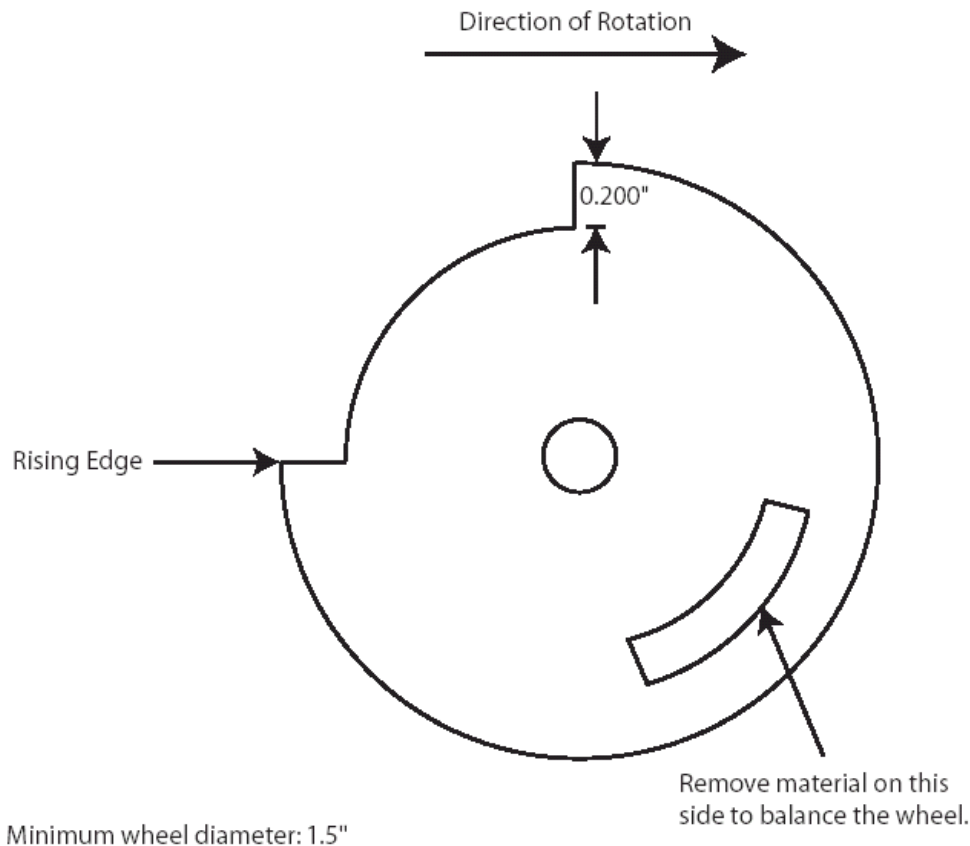
**Figure 8.** Tooth/Notch Triggers



**Figure 9.** Ford “Half-Moon” Trigger

Due to high noise sensitivity of magnetic sensors, it is required to use a Hall Effect sensor are with the **TECgt200's** sync pulse requirement. This would include most Hall effect, flying magnet sensors. As long as the sensor outputs a rising voltage to the **TECgt200** between 180° and 6° before TDC compression for the number one cylinder, it should work perfectly.

Terminal 39 on the ECU is used for cam sync inputs (as shown in **Figure 6**). If using a Hall effect or other sensor type that is powered by +5Volts, be sure that the output signal from the sensor is going into terminal 39. Keep in mind that when adapting an OEM cam trigger setup to a **TECgt200**, the wheel may need to be rotated to place the rising edge in the appropriate degree window for the **TECgt200**.



**Figure 11:** Proper cam trigger installation. This cam trigger occurs approx. 90° BTDC Compression on the #1 cylinder (as measured at the crank). Note the 87 degree (as measured on the cam wheel) “window” in which the rising edge must occur.

### 3.3.8 TDC Tooth Setup Software Adjustment Parameters

So, you took a lot of time to install your trigger wheel, and now you realize that you didn't get the trailing edge of the 11<sup>th</sup> tooth to align with the center of the magnetic sensor with the engine at TDC #1. What to do?

The WinTec4 software features a TDC setup parameter that allows users to manipulate the TDC point for the trigger wheel. There are two adjustable parameters:

**Change DFU “A” Trigger Wheel TDC**

**Change DFU “B” Trigger Wheel TDC**

For all but the odd-fire applications, the adjustment is only present for the DFU “A” TDC. The default setting for DFU “A” TDC is 11, signifying TDC alignments with the 11<sup>th</sup> tooth. If you are aligned with the 13<sup>th</sup> tooth at TDC, change this number to 13. Several late-model Bosch-equipped applications use our 60 (-2) tooth trigger wheel, but come from the factory with a different TDC tooth alignment. Typically, these setups are referenced to the 14<sup>th</sup> tooth for TDC, but you **MUST** confirm this on your application, since Bosch used a few different offsets through the years.

Odd-Fire applications have the ability to move the TDC reference for the second DFU (using the parameter “DFU “B” Trigger Wheel TDC”). This allows the user to define the odd-fire ignition split that is present on the engine. Refer to the Tuning Guide Section to determine the proper settings for this value.

Some applications may require more “mechanical timing” to compensate for large, high-overlap cams. Assuming the crank sensor is aligned with the 11<sup>th</sup> tooth at TDC, this can be done by entering a value for the “Change DFU “A” Trigger Wheel TDC” that is LESS than 11. Each tooth less than 11 represents 6 degrees of advance that is added to the Ignition Advance Table.

Some applications may require less “mechanical timing” (some rotary users may wish to do this). Assuming the crank sensor is aligned with the 11<sup>th</sup> tooth at TDC, this can be done by

entering a value for the “Change DFU “A” Trigger Wheel TDC” that is MORE than 11. Each tooth more than 11 represents 6 degrees of retard that is subtracted from the Ignition Advance Table.

If an odd-fire engine has the trigger wheel installed incorrectly, and the DFU “A” TDC parameter is changed to compensate for the error, the “DFU “B” Trigger Wheel TDC” parameter needs to be manipulated in the same amount. As an example, if the TDC for DFU “A” is at 11 and is moved to 10, the TDC for DFU “B” would need to be moved from 16 to 15.

The following pages outline the various situations that can be addressed through the TDC software parameters.

### **Situation A**

#### **Problem:**

Incorrect trigger wheel alignment results in undesired mechanical timing.

#### **Solution:**

With the engine at TDC #1, find the trigger wheel tooth that is aligned with the crank sensor. Enter the number of this tooth into the TDC Tooth Alignment Parameter. The timing will be shifted to make the Ignition Advance Table accurate.

#### **Method:**

The software will automatically RETARD the timing when a number GREATER THAN 11 is entered into the TDC Tooth Alignment Parameter. The timing will be automatically ADVANCED when a number LESS THAN 11 is entered.

### **Situation B**

#### **Problem:**

The engine needs less mechanical advance, and the crank sensor is aligned with the 11<sup>th</sup> tooth.

#### **Solution:**

Enter in the number “12” to the TDC Tooth Alignment Parameter. The timing values will be automatically RETARDED by 6 degrees. The Ignition Advance Table values will now be incorrect (the displayed values will be 6 degrees higher than the actual advance).

### **Situation C**

#### **Problem:**

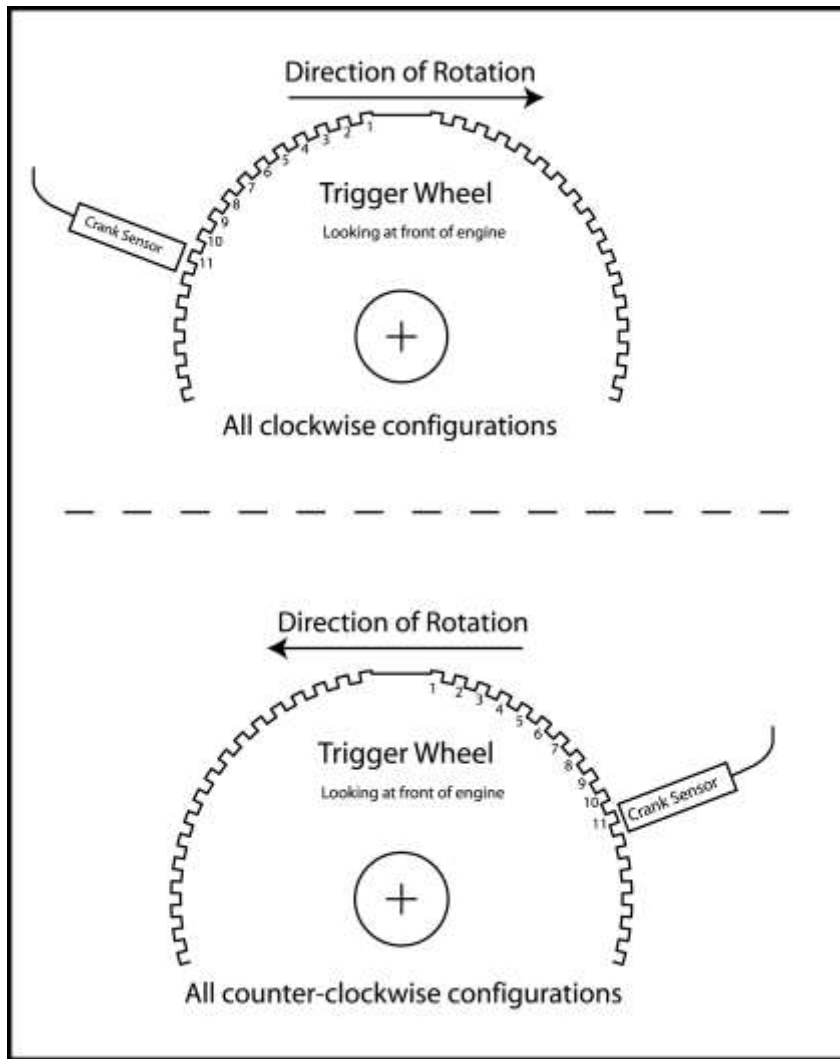
The engine needs more mechanical advance, and the crank sensor is aligned with the 12<sup>th</sup> tooth instead of the 11<sup>th</sup>.

#### **Solution:**

Enter in the number “11” to the TDC Tooth Alignment Parameter. The timing values will be automatically ADVANCED by 6 degrees. The Ignition Advance Table values will now be incorrect (the displayed values will be 6 degrees lower than the actual advance).

#### **Note:**

In the past, aligning the sensor with the 12<sup>th</sup> tooth would advance the mechanical timing by 6 degrees.



**Figure 13** - TDC tooth for two possible scenarios.

In a normal scenario, not considering software manipulation, aligning the magnetic sensor with anything other than the 11<sup>th</sup> tooth will cause an ignition timing retard or advance, depending on the direction of the misalignment. Each tooth represents six degrees, so if the sensor is aligned with the trailing edge of the 12<sup>th</sup> tooth, the timing will be advanced by six degrees. Conversely, if the sensor is aligned with the trailing edge of the 10<sup>th</sup> tooth, the timing will be retarded by six degrees. If some ignition advance is required for easier starting (high compression/radical cam timing engines, for example), aligning the sensor with the 12<sup>th</sup> or 13<sup>th</sup> tooth will yield 6° or 12° (respectively) of advance during cranking. Also check that the sensor is centered over the edge of the wheel.

## 4 Wiring the System

### 4.1 Introduction

The task of installing a **TECgt200** wiring harness may seem a bit intimidating at first. However, by dividing the wiring installation into a few small jobs, it can be accomplished by most installers in a reasonable amount of time.

**WARNING:** Always disconnect the battery when doing ANY electrical work on a vehicle. Use common sense when working around electrical systems, particularly the **TECgt200** DFU coils. The voltage output of the coils can be well over 40,000 Volts at a given instant.

#### 4.1.1 Suggestions on Crimp Terminals...

When crimping terminals to the sensor wires, care must be taken to ensure that a proper crimp is made. Improper crimps can lead to terminal failure and wire fatigue. To crimp properly, we recommend using a high-quality ratcheting crimp tool (such a tool is available from Electromotive). In the absence of a good crimp tool, the terminals can be soldered. Care should be taken to make absolutely certain that the solder penetrates the terminal and gets to the wire.

There are two main crimp styles used with the **TECgt200** sensors: Metri-Pack and Weather-Pack. Metri-Pack terminals have two crimp areas. One area crimps to the bare (stripped) wire and provides the electrical connection, and the other area crimps to the un-stripped wire housing to provide a strain relief. Metri-Pack connectors are pull-to-seat.

Weather-Pack terminals also have two crimp areas, but instead of one area acting as a strain relief, it is used to hold the connector seal in place. Therefore, when crimping a Weather-Pack terminal, always insert the cable seal before crimping. Weather-pack connectors are push-to-seat.

**Note : Soldered terminals will not tolerate much flexing. They may break if too much movement is allowed.**

The main TECgt200 connector is a Molex 123 type connector. Please go to this internet link and download this document:

[http://www.molex.com/pdm\\_docs/as/AS-34566-001.pdf](http://www.molex.com/pdm_docs/as/AS-34566-001.pdf)

It has important information on handling the TECgt200's new Molex connector.



## 4.2 Wiring ECU & Main Power

The two red/white (red with white tracer) wires on pins 33 and 53 are the switched ignition power. For redundancy, both red/white wires must be connected to the same switched +12V circuit. The ground wire is 12awg and on pin 73. The reason for the larger/thicker size of the ground wire is that the ECU is mainly in charge of switching the GROUNDS, not the +12 Volt power. As an example, the fuel injector and coil outputs are all pull-to-grounds. The TECgt200 does not use constant +12 Volt power.

Both red/white 18awg wires, [33] and [53], must be connected to the ignition switch. The black 12awg wire, [73] of the connector is connected to full time battery negative. See **Figure 15** for a wiring diagram.

If you are using the **TECgt200** Power Harness, refer to the next section on installing the Switched +12 Volt Input into the Power Harness.

### 4.2.1 Power Harness Installation

Electromotive's Power Harness (PN 070-40000) for the **TECgt200** is capable of supplying the +12Volt high-amperage power required to run the DFU's, injectors, EGO sensor heater and fuel pump. Included in the harness is a fuse block with four fuses (ignition, DFU's, Injectors and Fuel Pump are fused) and two relays to switch the power. Our custom harnesses are all built with the power harness pre-installed, so wiring them is even more straightforward. **Figure 15** gives an example of a typical Power Harness installation.

There are three breakouts in the Power Harness:

- **ECU Connections**
- **Power Inputs**
- **Power Outputs (w/ switched voltage input)**

#### ECU Connections

The **TECgt200** Connections are color-matched to the **TECgt200** harness.

- Light Green 20awg Wire: Connects to [57] (Fuel Pump Relay Ground)
- Yellow (from power harness) 20awg Wire: Connects to Switched +12v input

#### Power Inputs

The Power Inputs are color coded in standard fashion:

- Two Red/White 18ga Wire in parallel, pin [33] and [53]: connect to (Switched +12V input)
- Black 12awg Wire, pin [73]: Connect to Vehicle Battery - minus

#### Power Outputs (w/ switched voltage input)

The power outputs provide power for the DFU's, injectors, EGO sensor heater, and Fuel Pump. The switched voltage input is used to turn on the **TECgt200** ECU, and should be wired to a +12Volt source that is activated with the ignition key.

Purple/White Stripe 16awg: Injector Power (runs to all injectors)  
Red/White Stripe: DFU Power (pin "D" on DFU's)  
Green 16awg: Fuel Pump Positive and EGO Sensor Heater Positive  
Yellow 18awg: Switched +12 Volt Input (for **TECgt200** turn-on request)

The Wiring Diagrams in the DFU and Injector wiring sections of this manual show the terminals on which the power should be brought in. Any reference to fusing the power source in these sections is unnecessary when using the Power Harness, since the connections are already fused.

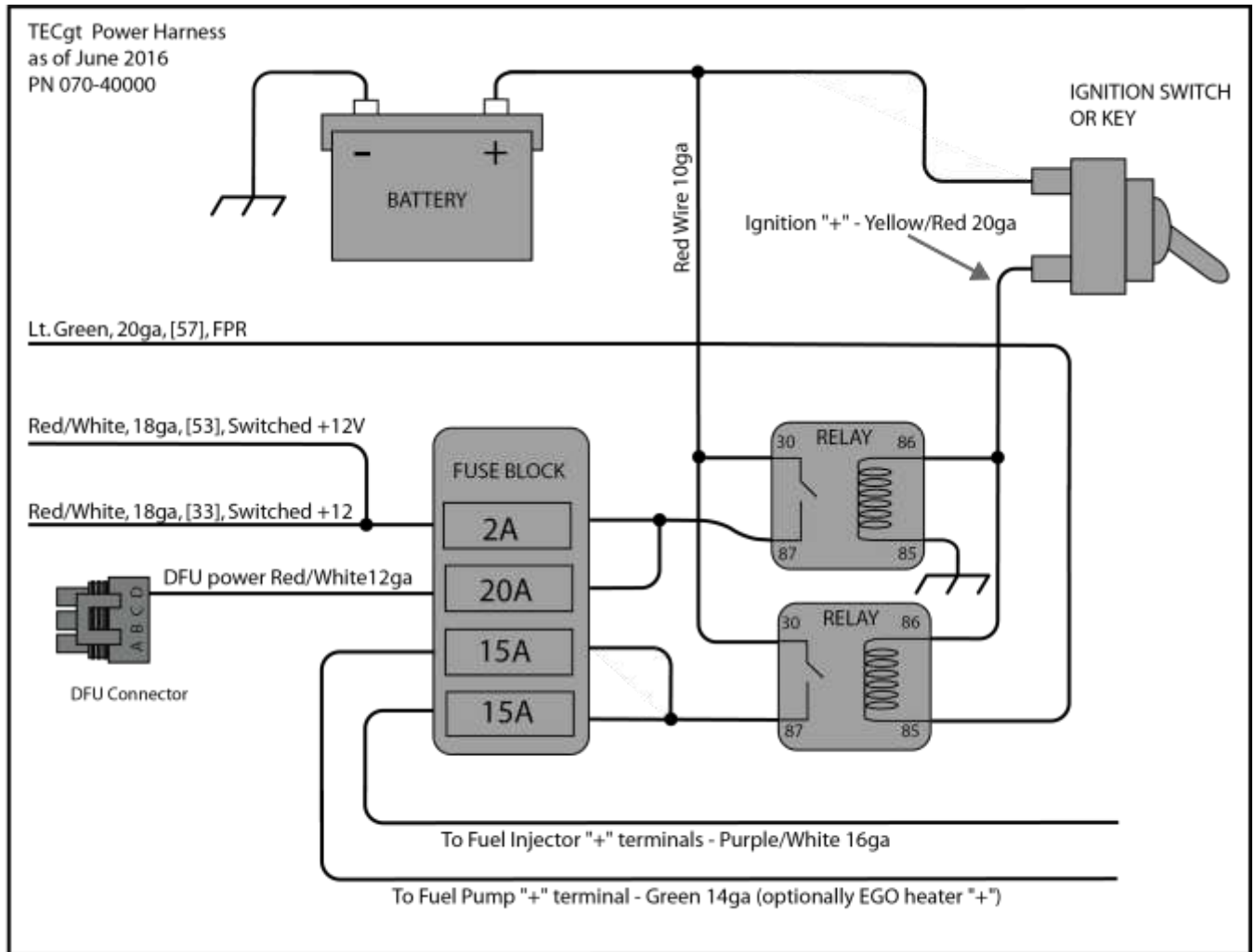


Figure 15. TECgt200 Power Harness (PN: 070-40000).

### 4.3 Wiring the Fuel Injectors

The Injector connectors **MAY** use pull-to-seat terminals. **DO NOT** crimp the terminals onto the wires until you have fed the wires through the connector!

When wiring the injectors, **you must** determine the correct wiring for your application. Injectors are wired according to these outputs:

- Injector drivers 1-4 use a Yellow base color. The stripe color indicates the channel (Black-Red-Green-Blue = Channel 1-2-3-4).
- Injector drivers 5-6 use a Light Blue base color. The stripe color indicates the channel (Black-Red = Channel 1-2).

- All injectors need a +12Volt connection on one terminal and a **TECgt200** Injector Output on the other terminal.
- The TECgt200 will not drive low impedance injectors.
- High Impedance injectors can be used with either 1 or 2 connected per channel. When using two per channel, wire them in parallel.

When using the Power Harness, refer to **Figure 15** to obtain the fused +12Volt source for the fuel injectors. It is the Purple w/ White stripe wire coming out of the Power Harness.

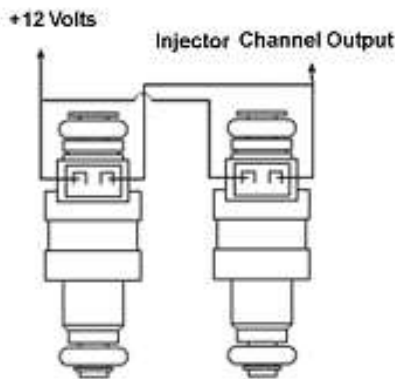
### 4.3.1 High vs. Low Impedance Injectors

The **TECgt200** is equipped with 6 fuel injector channels. These channels are pull-to-ground outputs, meaning that they provide a ground connection for the injectors when they fire.

**The TECgt200 injector channels can only operate high resistance injectors.** The 200 series ECUs are not capable of driving low impedance injectors without the aid of our injector driver module.

**Table 3.** Recommended fuel injector selection for various wiring configurations. Note that the values given are for individual injector resistance, NOT for the total circuit resistance. TBI-style injectors cannot be run.

Injector type	Individual Injector Resistance for 1 Injector per Driver	Individual Injector Resistance for 2 Injectors per Driver
High Impedance	6 ohms or above	12 ohms or above



**Figure 16:** Parallel wiring of fuel injectors. Note that injectors have an electrical polarity. Typically, positive is on the side marked above.

To determine the current flow through an injector circuit, follow the equation below.

$$\text{Current Flow through Injector Circuit} = \text{Battery Voltage} \div \text{Injector Circuit Resistance}$$

Injectors should always be wired in parallel when more than one injector is used on a channel (see **Figure 16**). When two injectors are used on a channel, the current flow will double in the individual output channel. Do not operate more than 2 high resistance injector per channel.

### 4.3.2 Injector Firing Schemes

Most engines will operate quite well using a phase-sequential injector firing mode. This firing mode pairs injectors together just like the waste-spark coil firing scheme. On a standard inline 4-cylinder four-stroke engine, cylinders 1 and 4 will always be on top dead center at the same time, but one cylinder will be on compression when the other is on exhaust. The same holds true for cylinders 2 and 3. As a result, it is possible to use just two injector channels to drive four low (or high) impedance injectors for this engine: simply pair the injectors for cylinders 1 and 4 to channel 1, and the injectors for cylinders 2 and 3 to channel 2. If a phase-sequential firing scheme is chosen in the software, each channel will fire once per revolution. This means that each cylinder will receive a pulse of fuel twice per engine cycle (once per revolution on a 4-stroke). This type of firing scheme requires only the standard Electromotive 60(-2) tooth trigger wheel on the crankshaft. No cam sensor is required. For an outline of the various firing options available with the **TECgt200**, see the section on injector and coil firing below.

- Regardless of engine firing order, the **TECgt200** fires its injector output channels in numerical order 1-2-3-4-(5-6). Injector channels must be wired appropriately to match an engine's firing order. Channels 5 and 6 are used in 6 cylinder operation.
- If an injection mode does not use all six output channels, it will reset after its intended number of channels have fired. As an example, a 4-cylinder phase-sequential setup will fire 1-2-1-2-1-2-etc. The remaining channels are reserved for staged injectors, and are keyed to channels 1 and 2, respectively.

As can be seen in the sections below, we have accounted for most injection scenarios.

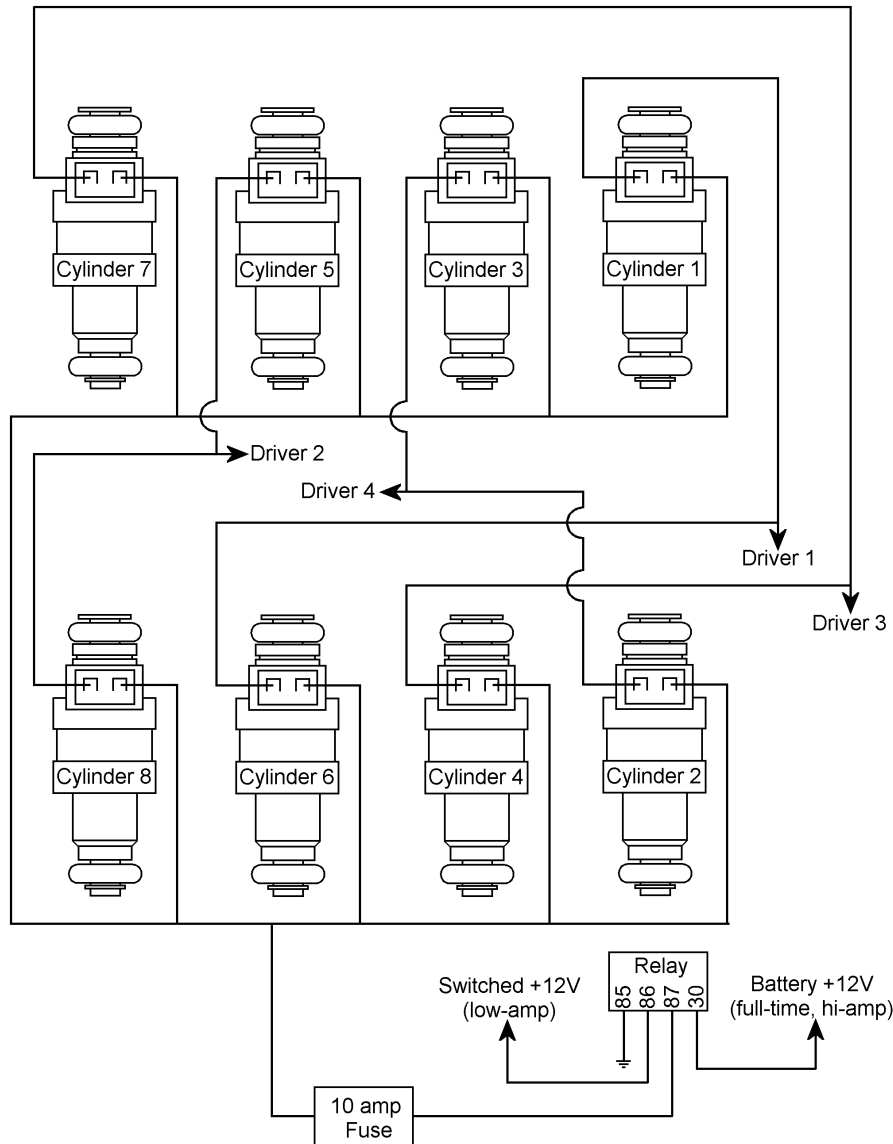
### 4.3.3 Staged Injection

An injection layout whereby there are “primary” and “secondary” injectors. The primary injectors would be sized such that the engine will idle nicely, while the secondary injectors would supply additional fuel needed for high-rpm, high-load situations. Most rotary applications utilize this injection method, since there would otherwise only be one injector per rotor for idling and high-load conditions. On a two-rotor engine with 400HP, at least a 120 lb/hr injector would be needed for each rotor, if only one injector were to be installed. However, with this injector in place, the engine would not be able to idle at a normal RPM, since the injector would be supplying far too much fuel, even with the shortest possible pulse width. To avoid this problem, 55 lb/hr primary and 100 lb/hr secondary injectors could be used. Piston engines with very high rpm power bands (like motorcycle engines) can also benefit from staged injection for the same reasons as the rotary example. Staged injection can be used with sequential, phased sequential, and TBI firing schemes. The WinTec software dedicates the unused injector channels for each setup for staged injectors.

When Staged Injection is desired, connect the secondary injectors to channels 5 and 6.

### 4.3.4 Phase-Sequential Injection

Most applications will use the phase-sequential firing option. This firing scenario pairs cylinders that share their TDC's to the same injector channels. As such, one injector channel fires two injectors: one on compression and the other on exhaust. Each injector channel will fire once per revolution, so each cylinder will see a shot of fuel on both the exhaust and compression stroke. In an 8-cylinder application, each injector channel has its own staged injector channel. 16 low-impedance injectors could be used with this firing scenario. See **Figure 20** for a typical 8-cylinder phase-sequential injector wiring schematic.



**Figure 20:** 8-cylinder phase-sequential injector wiring for firing order 1-8-4-3-6-5-7-2.

### 4.3.5 Full Sequential Injection

The biggest difference between full sequential injection and other injection types is that full sequential injection requires the use of a cam trigger in addition to the crank trigger. The cam trigger is used to provide a reference pulse for Top Dead Center compression. The crankshaft trigger knows the location of TDC, but on a 4-stroke engine, TDC is not all that is needed to determine which cycle the engine is on. For this, a camshaft reference is needed. With a full sequential setup, each injector channel is independent, and each injector is fired once per engine cycle (every two revolutions on a four stroke) on the end of the exhaust stroke. Rotary and 2-stroke applications are inherently full sequential without the need for a cam reference, since their engine cycles occur in only one revolution. Consequently, rotaries and 2-strokes will inject fuel on every TDC event. The TECgt200 cannot operate a V8 engine in Full Sequential mode.

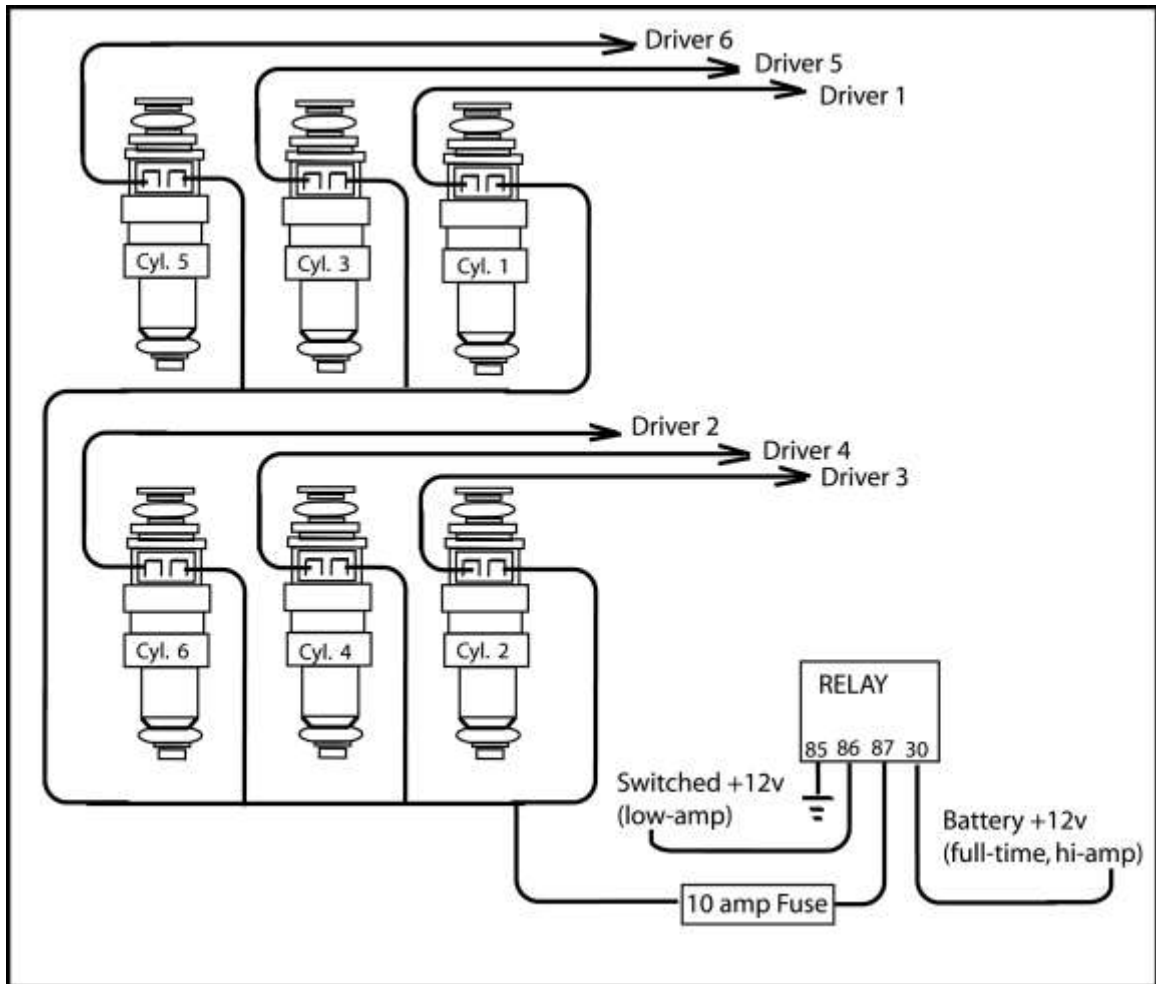
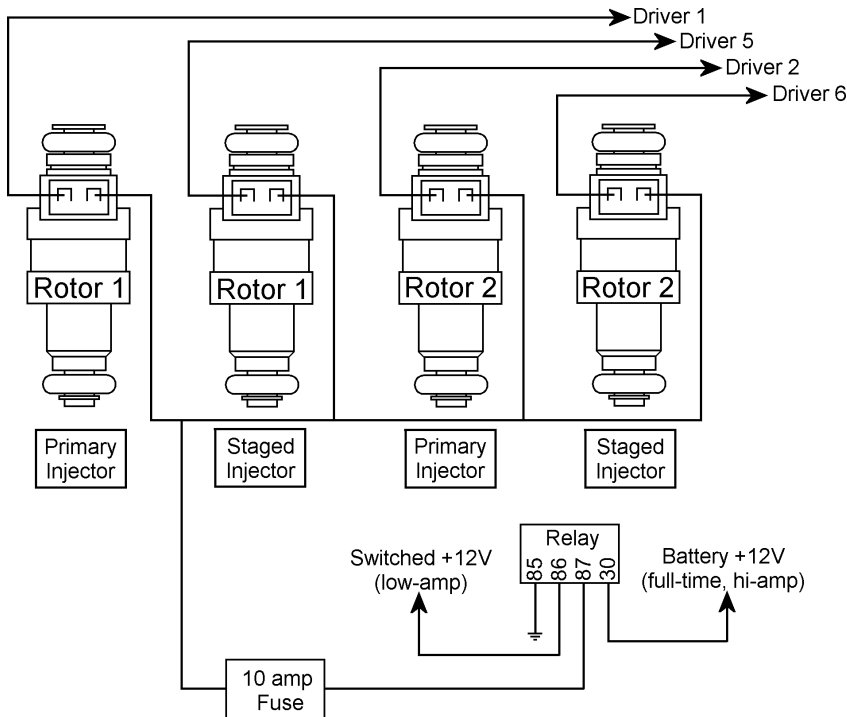


Figure 21. 6-cylinder full-sequential injection wiring for a 1-6-2-4-3-5 firing order.

### 4.3.6 Rotary Engine Injection

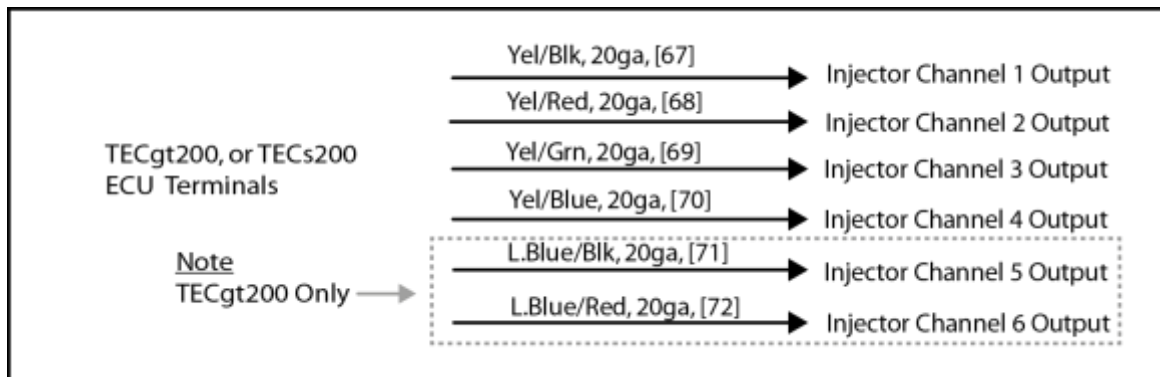
Fuel injected rotary engines typically come from the factory with a staged injection setup. One injector is the primary injector, and should be fired at all times. The other injector is the staged injector, and should be turned on gradually at medium and high RPM / Load points. Since a rotary engine completes a combustion cycle every revolution with both rotors, the rotary injector firing mode will fire the injectors on every revolution. Rotor 2 will fire 180° after rotor 1. The two staged injectors will be paired to rotor 1 and rotor 2. The staged injector pulse width is determined by the settings in the Staged Injector Pulse Width Table in the software. **Figure 22** shows the necessary wiring for a rotary injection application.



**Figure 22** Rotary injector wiring.

### 4.3.7 Injector Channel Pinout

The injector channels are connected to the below colors and terminal numbers.



## 4.4 Wiring Ignition Coil Primary Sides

### 4.4.1 Introduction

The TECgt200 has the ability to operate either the older style standard ignition coils or more recent Driver on Coil (DOC) coils. If DOC coils are selected, the customer must set a fixed dwell time in the calibration. Failure to select DOC and set a dwell time will cause damage to the DOC coils. Use the section directly below to wire Electromotive's standard DFU's. Jump to the next section for instructions on wiring DOC logic driven coils.

### 4.4.2 Standard Direct Fire Units, DFU's

DFU's are made by Electromotive in two variants: 2-coil and 3-coil. Each coil drives two spark plugs in waste-spark ignition setups. Eight cylinder engines will use two 2-coil DFU's. 2-rotor engines will use 4 single tower coil units. Two cycle applications will use single tower coils as well.

The DFU's are driven by a 12-volt charging system housed in the **TECgt200** ECU. For the Electromotive DFU wiring requirements, refer to **Figures 25** below.

### 4.4.3 Wiring Standard DFU's Coils

**The DFU connectors use pull-to-seat terminals. DO NOT crimp the terminals onto the wires until you have fed the wires through the connector!**

Before wiring the DFU's, you must select the right configuration below. Each standard Electromotive DFU has a 4 pin connector on it.

- **2-Coil DFU's (Part Number 070-33400)**

The 2-coil DFU's utilize three of the four terminals in their yellow connector. Here is the pin out:

Terminal A	Ground Pulse for Coil A
Terminal B	Ground Pulse for Coil B
Terminal C	Unused
Terminal D	Full-Time +12 Volt Source (9 amps)

On a standard inline 4-cylinder four-stroke application, this DFU will be used. On 8 cylinder or dual-plug 4-cylinders, two of these DFU's will be used.

- **3-Coil DFU's (Part Number 070-33600)**

The 3-coil DFU's utilize all four of the terminals in the yellow connector. Here is the pin out:

Terminal A	Ground Pulse for Coil A
Terminal B	Ground Pulse for Coil B
Terminal C	Ground Pulse for Coil C
Terminal D	Full-Time 12 Volt Source (9 amps)

On a standard 6-cylinder even-fire application, this DFU will be used.

- The **TECgt200** harness has two cables for the DFUs. Both cables have three 16awg wires with a shield.
- 6 or 4 cylinder engines with single spark plugs use only the first cable, 8, 12 and Dual plug engines use both cables

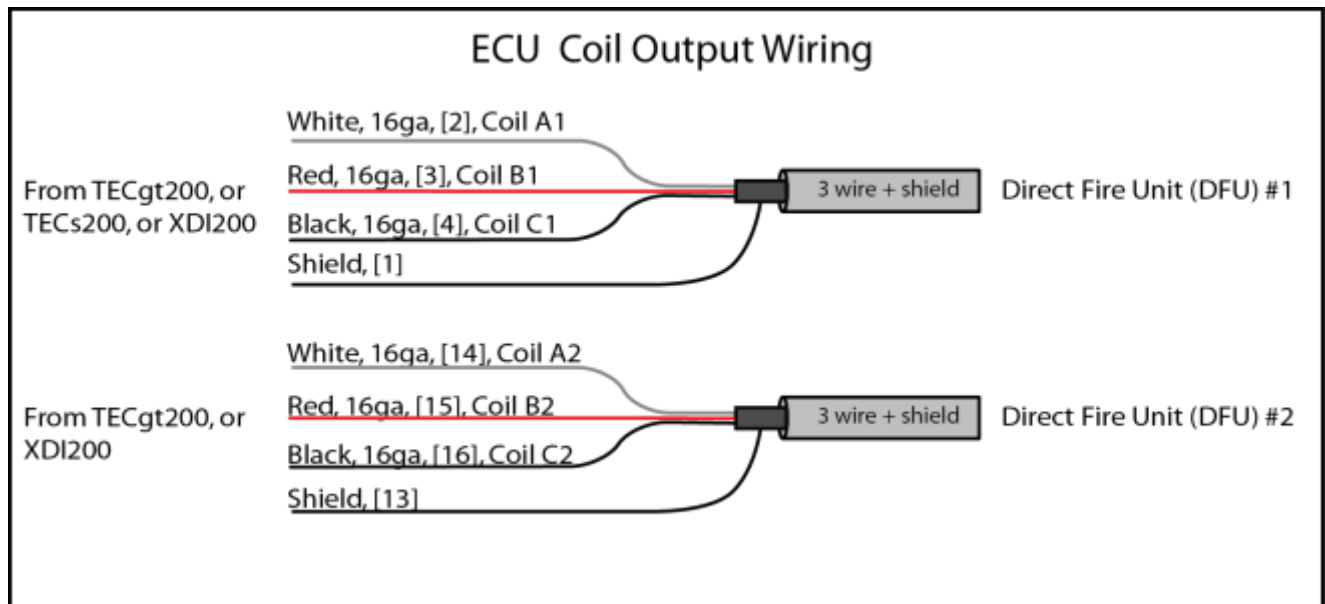


- **4- Coil DFU's (Part Number 070-33400)**

The 4-coil DFU is actually two 2-coil DFU's. When this part number is specified, two 070-33400 DFU's will be used. The first DFU should be wired in the same manner as part number 070-33400.

The first step in wiring the DFU's is to install the ground wire. The DFU's come from our factory with a ground wire pre-installed on a tapped, un-anodized hole. This wire **MUST** be connected to chassis/battery ground. **FAILURE TO DO SO MAY RESULT IN SEVERE ELECTRICAL SHOCK TO THE USER!!** Electrical shock will occur if the DFU is not grounded, and someone touches it while touching chassis ground (with the engine running). If desired, the ground wire may be relocated elsewhere on the DFU chassis. However, you will need to scrape off the anodization from the chassis at the point of contact, since the anodizing acts as an electrical insulator. Also, loose coil screws may cause an electrical shock as well, since they must be grounded to the case at all times. **Always make sure that both the coil screws and the ground wire are securely fastened.**

After the DFU has been grounded, the rest of the wiring may begin. The DFU's come shipped with the appropriate connectors. Terminal D on all DFU's should be connected to a **FUSED 12 VOLT SOURCE** that can pull **9 AMPS** of current. In the wiring harness, the outputs for Coils A, B, and C are routed in the same shielded-cable housing. On an 8 cylinder, the outputs for DFU 2 (A2, B2) are routed in a separate shielded-cable housing. These are all 9amp pull-to-ground outputs; that is, they create a ground path every time a coil charges. When the coils fire, the outputs "float," with no connection to ground or power. If the wires need to be spliced or lengthened, 16awg wire should be used. See **Figure 25** for details on the coil outputs in the wiring harness. The TECgt200 has both standard DFU coil outputs and logic outputs. When using the Standard DFU outputs showed below, remove or tape off the DOC wires [5,6,7 and 10,11,12].



**Figure 25:** ECU Coil Output Wires (note: shield wire is connected inside the **TECgt200** unit, not connected at the coils).

## WARNING:

The DFU chassis **MUST** be grounded. A ground wire must be connected to battery negative, or to a good chassis ground. **FAILURE TO GROUND THE DFU'S MAY RESULT IN SEVERE ELECTRICAL SHOCK!** Also, poorly grounded DFU's may result in poor engine performance, and can cause engine damage!! Use the drilled and tapped hole next to the yellow connector for the ground wire. If desired, the unit may instead be grounded at one of the four bolt holes. However, **you will need to scrape off the anodizing under the bolt head.** The anodizing is an electrical insulator, so unless it is scraped down to bare aluminum, it will not provide a good connection to ground. If more than one DFU is used on a vehicle, each one will require its own ground wire.

Additionally, make sure that the **coil screws** are fully tightened at all times!!

### 4.4.4 Spark Plug Wiring High Voltage Side

The coils fire in a specific order for each engine configuration. The proper coil must be connected to the correct cylinder in the firing order.

#### Coil Notation

The following notation is used when referring to coils. A letter and a number are combined to identify a coil. The letter refers to the coil location on the DFU. The coil located closest to the connector is Coil A. The coil next to it is Coil B. If the DFU contains three coils, the last coil is Coil C. The number identifies the DFU that the coils are on. In an engine configuration using only one DFU, the number following the letter is 1. Coil notation is shown in Figure 26.

Note: Each coil has two towers for spark plug wires. The towers are identical and should be thought of as the same coil. For example, if the engine setup guide refers to cylinder 1 connected to Coil A1 and cylinder 6 connected to Coil A1, you can connect your spark plug wires for the respective cylinders to EITHER tower.

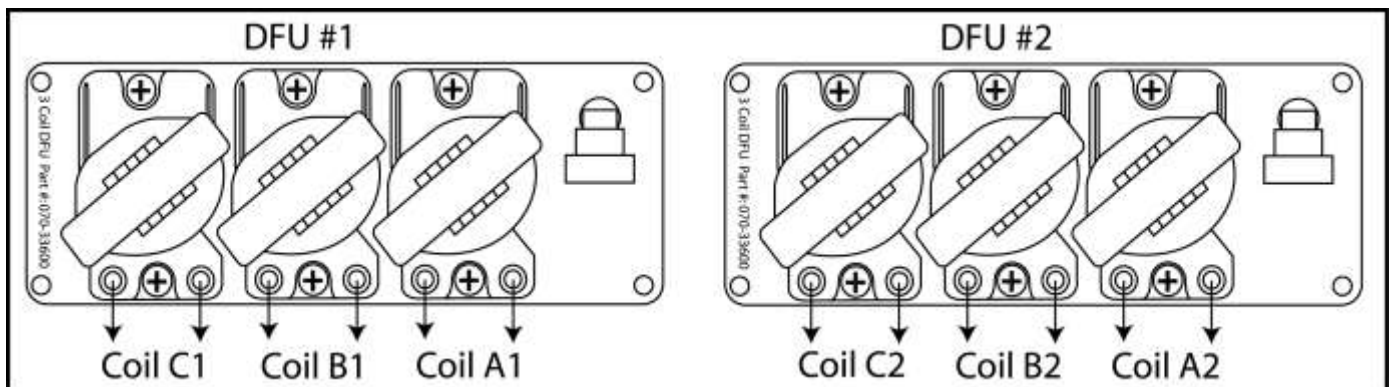


Figure 26 : Coil notation

Figure 26 shows a configuration using two 3-coil DFU's. If you are using 2-coil DFU's the numbering is the same except there is not C1 and C2. If your application requires only one DFU, then A2, B2, and C2 will not be needed.

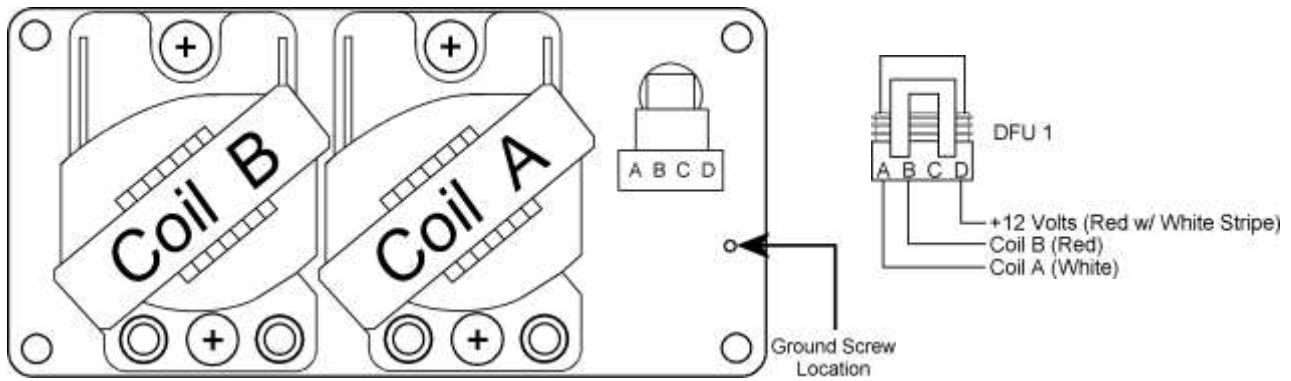
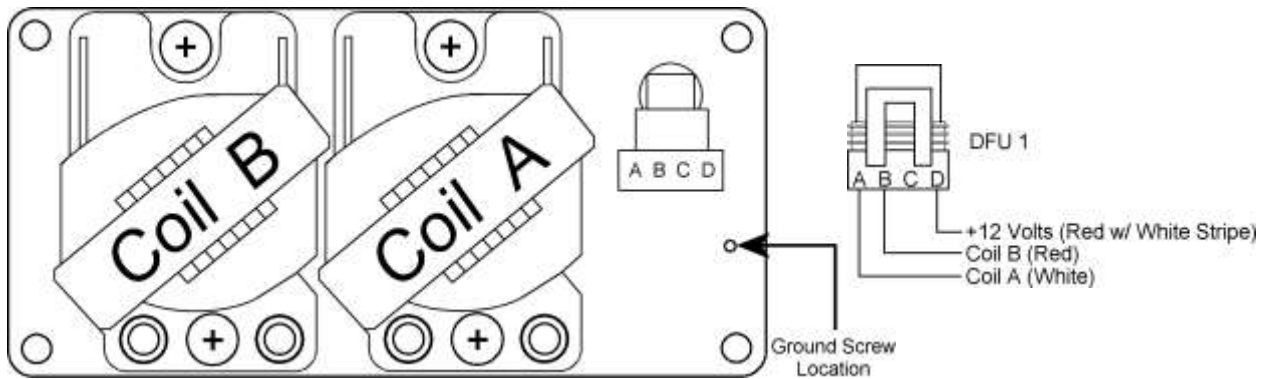
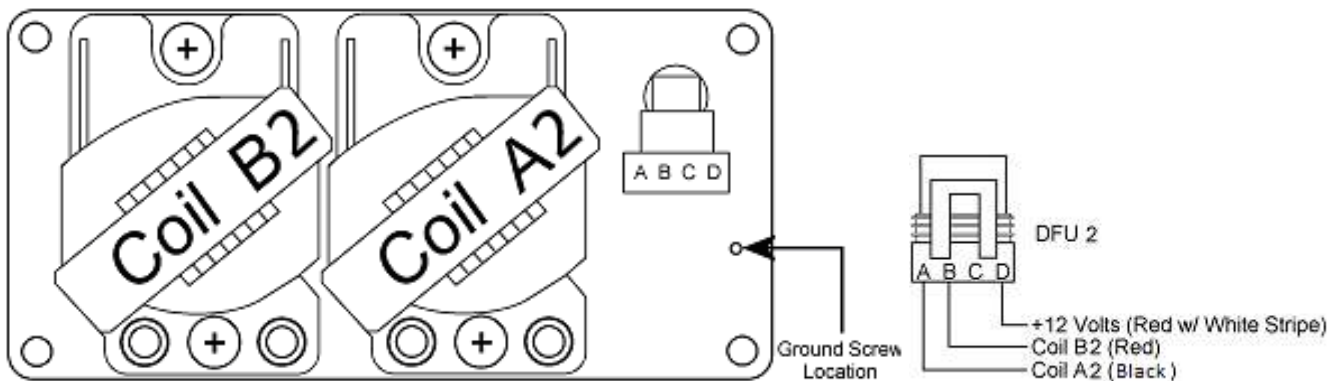


Figure 27. 4-Cyl DFU Setup

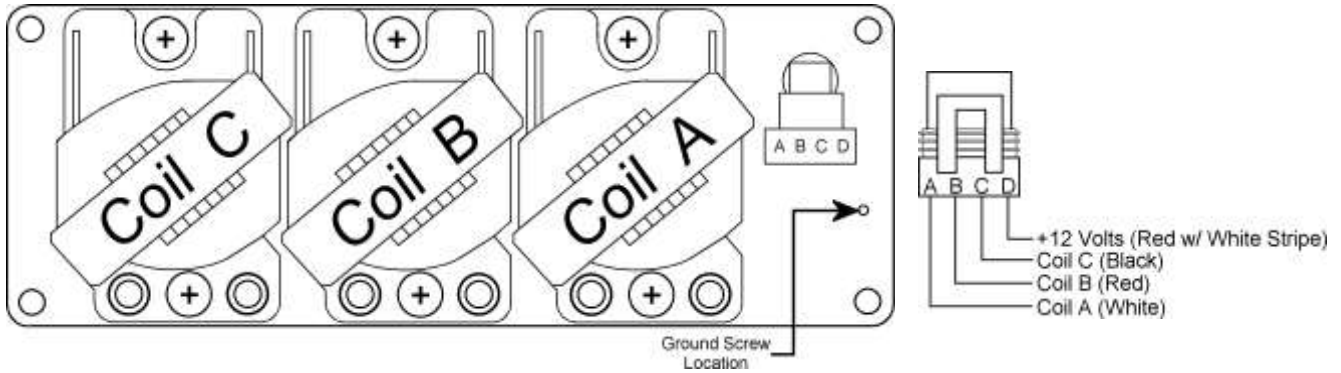


1<sup>st</sup> DFU

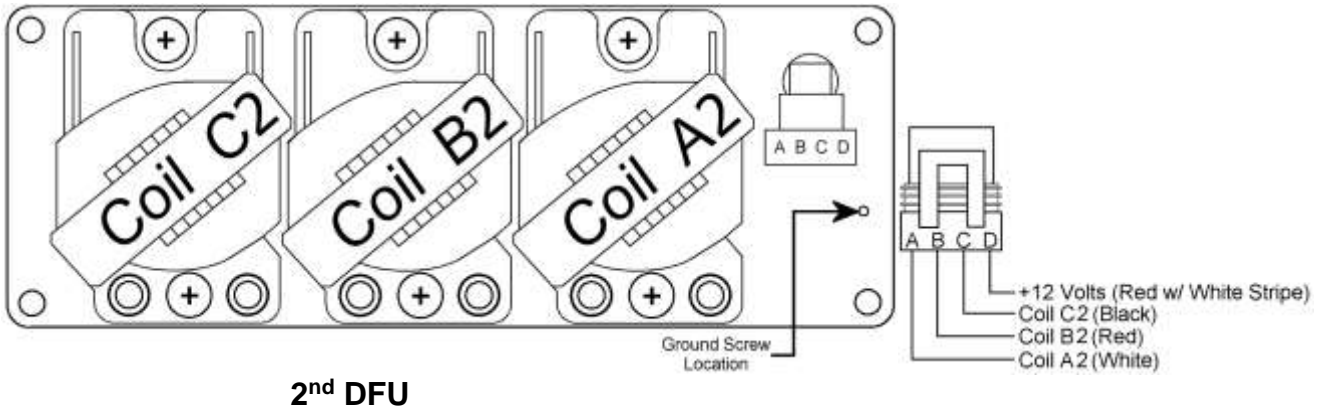
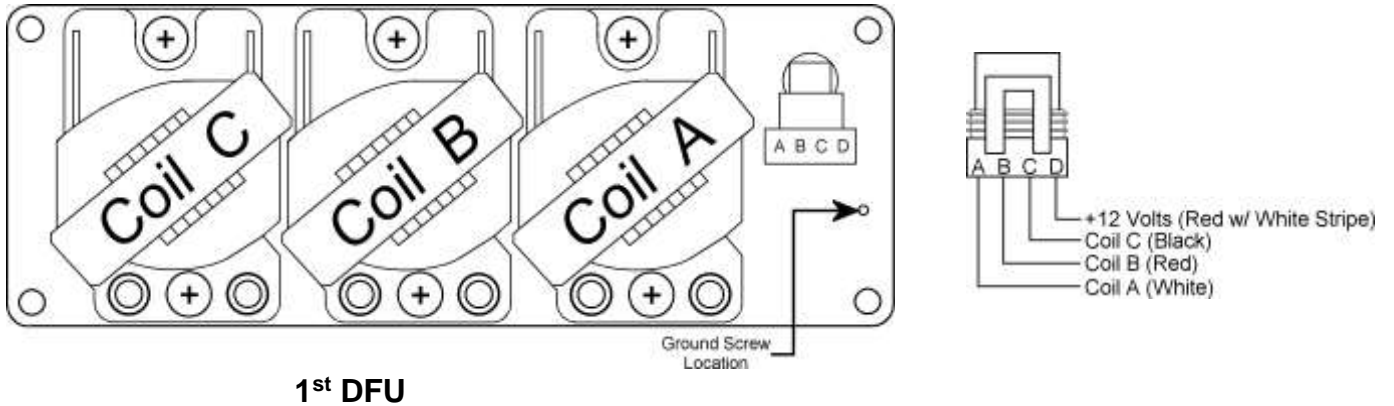


2<sup>nd</sup> DFU

**Figure 28: 8-Cyl and 4-cyl Dual Plug DFU Setup. Note that the 2<sup>nd</sup> DFU coils will not be labeled C and D from Electromotive. When the 2<sup>nd</sup> DFU is wired as shown, the coil labeled “A” will fire coil output “A2.” The coil labeled “B” will fire coil output “B2.”**



**Figure 29: 6-Cyl DFU Setup**



**Figure 30:** (The above picture is from a twin-plug 6 Cyl.), if running a V8 the first DFU will have coils A1, B1 the second DFU will have coils A2, B2.

## 4.5 Ignition Firing Order

For the engine to run correctly, the coils must be connected to the appropriate cylinders. Since the Electromotive DFU's utilize waste-spark coils, it is necessary to know the firing order of an engine to determine which cylinders should be paired together.

- When a 1, 2, or 4-cylinder engine is chosen in the software setup, coil channels A and B will be fired alternately, every 180° of crankshaft rotation. The firing goes: **A – 180° – B – 180° – A – 180° – B – etc...**
- When a 3, or 6-cylinder engine is chosen in the setup, coils A, B, and C will fire every 120° of crankshaft rotation. The firing goes:  
**A – 120° – B – 120° – C – 120° – A – 120° – B – 120° – C – etc...**
- When an 8-cylinder engine is chosen, DFU #1 Coils A1, B1 and DFU #2 Coils A2, B2 will fire every 90° of crankshaft rotation. However, on the 8-cylinder setup, the coils fire A1-A2-B1-B2 instead of A1-B1-A2-B2. The firing goes:

A1 - 90° – A2 - 90° – B1 - 90° – B2 - 90° – **A1 - 90° – B1 - 90° – A2 - 90° – B2 – etc...**

**Note:** To clarify these seemingly complex firing patterns, write your firing order into the appropriate engine setups found below and wire them accordingly.

### 4.5.1 Common Engine Sparkplug Wiring

#### 4.5.1.1 Chevy V8

**Firing Order: 1-8-4-3-6-5-7-2**

Coil Firing Order:	<b>A1</b>	<b>A2</b>	<b>B1</b>	<b>B2</b>	<b>A1</b>	<b>A2</b>	<b>B1</b>	<b>B2</b>
Engine Firing Order:	<b>1</b>	<b>8</b>	<b>4</b>	<b>3</b>	<b>6</b>	<b>5</b>	<b>7</b>	<b>2</b>

As can be seen, Coil A1 will be used for cylinders 1&6, Coil B1 for cylinders 4&7, Coil A2 for cylinders 5&8, and Coil B2 for cylinders 2&3.

#### 4.5.1.2 Honda 4-cylinder

**Firing Order: 1-3-4-2**

Coil Firing Order:	<b>A1</b>	<b>B1</b>	<b>A1</b>	<b>B1</b>
Engine Firing Order:	<b>1</b>	<b>3</b>	<b>4</b>	<b>2</b>

Cylinders 1&4 are paired to Coil A1. Cylinders 2&3 are paired to Coil B1.

#### 4.5.1.3 Mazda 2-Rotor Rotary

**Spark Plug Setup: Leading & Trailing Plugs on Both Rotors**

Coil Firing Order:	<b>A1</b>	<b>A2</b>	<b>B1</b>	<b>B2</b>
1 <sup>st</sup> or 2 <sup>nd</sup> Rotor:	<b>1<sup>st</sup> rotor</b>	<b>1<sup>st</sup> rotor</b>	<b>2<sup>nd</sup> rotor</b>	<b>2<sup>nd</sup> rotor</b>
Leading or Trailing:	<b>Leading</b>	<b>Trailing</b>	<b>Leading</b>	<b>Trailing</b>

Note: In the software, the timing split between the leading and trailing spark plugs can be set for different engine speeds.

#### 4.5.1.4 4-cylinder 2-stroke

##### Firing Order 1-2-3-4

Coil Firing Order:	<b>A1</b>	<b>A2</b>	<b>B1</b>	<b>B2</b>
Engine Firing Order:	<b>1</b>	<b>2</b>	<b>3</b>	<b>4</b>

#### 4.5.1.5 Coil-Per-Plug Applications

The following engines utilize a coil-per-plug ignition setup:

- 4-strokes:** 1-cyl, 2-cyl 180°, 3-cyl (all), 4-cyl odd fire
- Rotaries:** ALL
- 2-strokes:** ALL

For these applications, it will be necessary to use our single tower coils, as shown in Figure 36.

### 4.6 Coil and Injector Firing Schemes

The **TECgt200** software is able to run a multitude of different engine configurations. To determine the proper wiring of coils and injectors for a given engine, it is necessary to understand the points at which the coils and injectors are fired as functions of engine position. The following pages outline the different injection and ignition firing patterns that are available on the **TECgt200**. It will be necessary to know the firing order for your engine before using the engine configuration tables (some common firing orders are given in the following section). Once this is known, simply wire the vehicle's injectors and coils to reflect the data in the tables.

#### 4.6.1 Injector and Coil Firing Patterns for EVEN-FIRE Engines

1 Cylinder <<< 1st revolution >>> 2nd revolution >>>		
Crank Degrees	0°	360°
Coil Channels	A	A
Injector Channels	1 (2)	
( ) = staged	1 (2)	1 (2)
Firing Order		

(1 Coil, coil-per-plug)  
Full Sequential  
Phase Sequential

2 Cylinder <<< 1st revolution >>> 2nd revolution >>>		
Crank Degrees	0°	360°
Coil Channels	A	A
Injector Channels	1 (3)	2 (4)
( ) = staged	1 (2)	1 (2)
Firing Order		

(coil-per-plug)  
Full Sequential  
Phase Sequential

3 Cylinder <<< 1st revolution >>> 2nd revolution >>>						
Crank Degrees	0°	120°	240°	360°	480°	600°
Coil Channels	A	B	C	A	B	C
Injector Channels	1 (4)		2 (5)		3 (6)	
( ) = staged	1 (4)	2 (5)	3 (6)	1 (4)	2 (5)	3 (6)
Firing Order						

(coil-per-plug)  
Full Sequential  
Phase Sequential

4 Cylinder				
Crank Degrees	0°	120°	240°	360°
Coil Channels	A	B	A	B
Injector Channels	1 (5)	2	3 (6)	4
( ) = staged	1 (3,5)	2 (4,6)	1 (3,5)	2 (4,6)
Firing Order				

(Coil-per-plug)  
Full Sequential  
Phase Seq.

4 Cylinder dual plug				
	<<< 1st revolution		2nd revolution >>>	
Crank Degrees	0°	180°	360°	540°
Coil Channels	A1	B1	A1	B1
	A2	B2	A2	B2
Injector Channels				
( ) = staged	1 (5)	2	3 (6)	4
	1 (3,5)	2 (4,6)	1 (3,5)	2 (4,6)
Firing Order				

(DFU-1 4 cyl.)  
(DFU-2 4 cyl.)  
Full Sequential  
Phase Seq.

6 Cylinder						
	<<< 1st revolution			2nd revolution >>>		
Crank Degrees	0°	120°	240°	360°	480°	600°
Coil Channels	A	B	C	A	B	C
Injector Channels						
( ) = staged	1 (4)	2 (5)	3 (6)	1 (4)	2 (5)	3 (6)
Firing Order						

(3 Coils)  
Phase Sequential

8 Cylinder								
	<<< 1st revolution				2nd revolution >>>			
Crank Degrees	0°	90°	180°	270°	360°	450°	540°	630°
Coil Channels	A1	A2	B1	B2	A1	A2	B1	B2
Injector Channels								
( ) = staged	1 (5)	2 (6)	3	4	1 (5)	2 (6)	3	4
Firing Order								

(2) two Coil DFU's  
Phase Sequential

### 4.6.2 Injector and Coil Firing Patterns for ROTARY Engines

1 rotor	
Coil Channels	A1 - leading
	Rotary Split Table
	A2 - trailing
Injector Channels	1 (2)
( ) = staged	

(coil-per-plug)  
- equal tooth offsets  
(coil-per-plug)  
Full Sequential

2 rotor		
Crank Degrees	0°	180°
Coil Channels	A1 - leading	B1 - leading
	Rotary Split Table	Rotary Split Table
	A2 - trailing	B2 - trailing
Injector Channels	1 (3)	2 (4)
( ) = staged		
Firing Order		

(coil-per-plug)  
- equal tooth offsets  
(coil-per-plug)  
Full Sequential

NOTES : Coil Channel A1 = 1st DFU - Coil A  
Coil Channel B1 = 1st DFU - Coil B  
Coil Channel A2 = 2nd DFU - Coil A  
Coil Channel B2 = 2nd DFU - Coil B

### 4.6.3 Injector and Coil Firing Patterns for 2-CYCLE Engines

1 Cylinder	
Coil Channels	A
Injector Channels	1 (2)
( ) = staged	

(Coil-per-plug)  
Full Sequential

3 Cylinder			
Crank Degrees	0°	120°	240°
Coil Channels	A	B	C
Injector Channels			
( ) = staged	1 (4)	2 (5)	3 (6)
Firing Order			

(Coil-per-plug)  
Full Sequential

2 Cylinder			
Crank Degrees	0°	120°	(Coil-per-plug)
Coil Channels	A	B	
Injector Channels ( ) = staged	1 (3)	2 (4)	Full Sequential
Firing Order			

4 Cylinder					
Crank Degrees	0°	120°	240°	360°	(Coil-per-plug)
Coil Channels	A	B	C	A	
Injector Channels ( ) = staged	1 (5)	2	3 (6)	4	Full Sequential Phase Seq.
Firing Order	1 (3,5)	2 (4,6)	1 (3,5)	2 (4,6)	

### 4.6.4 Injector and Coil Firing Patterns for ODD-FIRE Engines

2 Cylinder Odd Fire (Default : Tooth Offset A = 11, B = 18 for Harley Davidson)					
<<< 1st revolution		>>> 2nd revolution >>>			
Crank Degrees	0°	Tooth Offset	360°	360° + Tooth Offset	coil-per-plug
Coil Channels	A1	A2	A1	A2	
Injector Channels ( ) = staged	1 (3)		2 (4)		Full Sequential Phase Sequential
TDC Event Order (Not the Firing Order)					

NOTE : Harley-Davidson MUST have 3 degrees in the Timing Split Table !

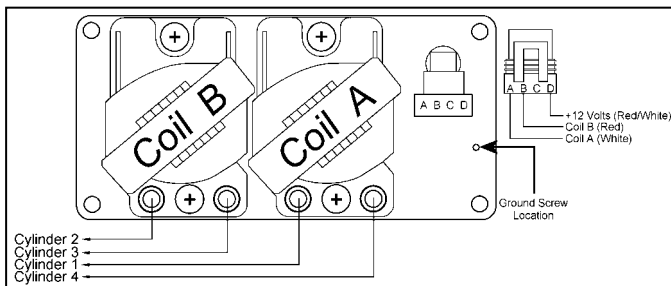
4 Cylinder Odd Fire (Default : Tooth Offset A,B = 11)									
<<< 1st revolution		>>> 2nd revolution >>>							
Crank Degrees	0°	Tooth Offset	180°	180° + Tooth Offset	360°	360° + Tooth Offset	540°	540° + Tooth Offset	coil-per-plug
Coil Channels	A1	A2	B1	B2	A1	A2	B1	B2	
Injector Channels ( ) = staged	1 (5)		2		3 (6)		4		Full Sequential Phase Sequential
TDC Event Order (Not the Firing Order)									

### 4.6.5 Examples of Typical Engine Setups

Example: 2 rotor			
Coil Channels	A1 - leading Rotary Split table	B1 - leading Rotary Split table	(coil-per-plug) - equal tooth offsets (coil-per-plug)
Injector Channels ( ) = staged	1 (3)	2 (4)	
Firing Order	1	2	

Rotor 1 : Leading = Coil A1 Rotor 2 : Leading = Coil B1  
 Rotor 1 : Trailing = Coil A2 Rotor 2 : Trailing = Coil B2

Rotor 1 : Injector 1 = Primary, Injector Channel 3 = Staged  
 Rotor 2 : Injector 2 = Primary, Injector Channel 4 = Staged



**Figure 32.** Typical In-Line 4-cylinder DFU wiring. Firing Order 1-3-4-2 depicted here.



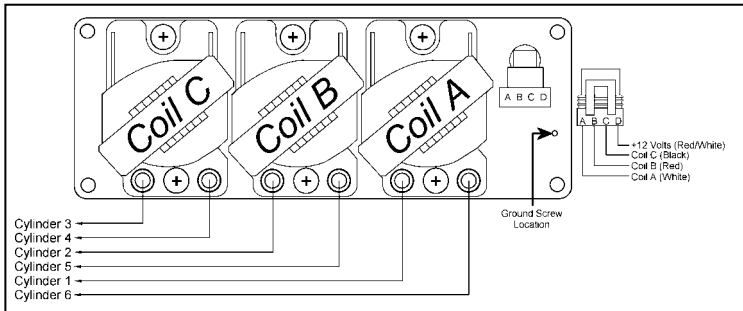
Example : 6 Cylinder

	<<< 1st revolution			2nd revolution >>>		
Crank Degrees	0°	120°	240°	360°	480°	600°
Coil Channels	A1	B1	C1	A1	B1	C1
Injector Channels	1	2	3	4	5	6
Injector Channels ( ) = staged	1 (4)	2 (5)	3 (6)	1 (4)	2 (5)	3 (6)
Firing Order	1	5	3	6	2	4

Coil A1 = Cylinders 1 and 6  
 Coil B1 = Cylinders 5 and 2  
 Coil C1 = Cylinders 3 and 4

phase sequential full sequential  
 Injector Channel 1 : Cylinders 1 & 6  
 Injector Channel 2 : Cylinders 5 & 2  
 Injector Channel 3 : Cylinders 3 & 4  
 Injector Channel 4 : unused  
 Injector Channel 5 : unused  
 Injector Channel 6 : unused

Cylinder 1  
 Cylinder 5  
 Cylinder 3  
 Cylinder 6  
 Cylinder 2  
 Cylinder 4

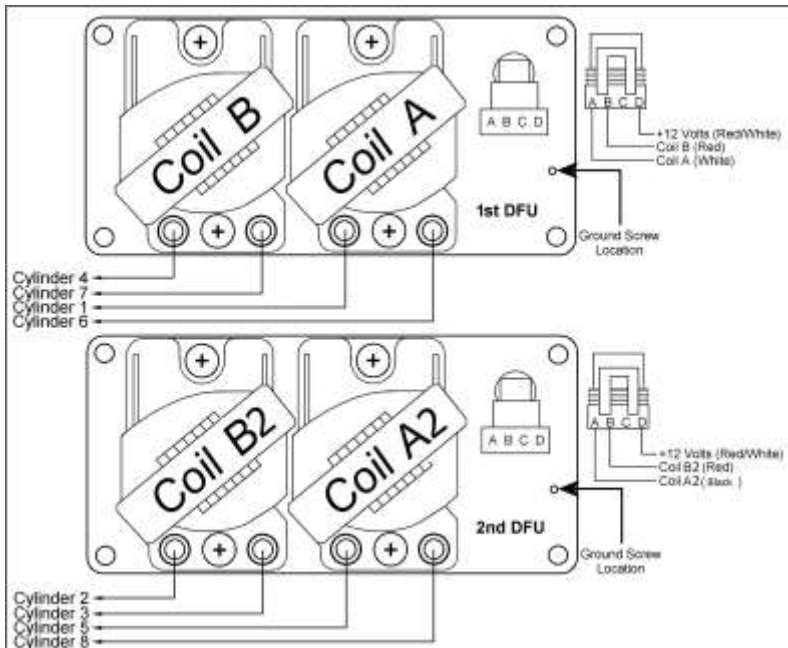


**Figure 33.** Typical In-Line 6-cylinder DFU wiring. Firing Order 1-5-3-6-2-4 depicted here.

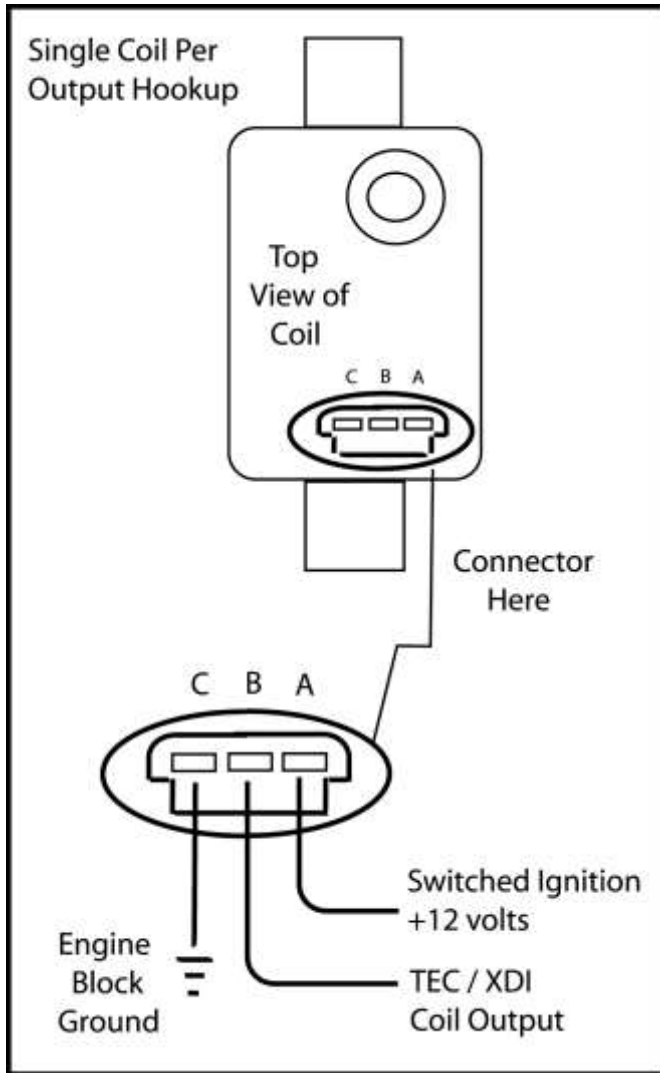
### 8 Cylinder

	<<< 1st revolution				2nd revolution >>>			
Crank Degrees	0°	90°	180°	270°	360°	450°	540°	630°
Coil Channels	A1	A2	B1	B2	A1	A2	B1	B2
Injector Channels								
Injector Channels ( ) = staged	1 (5)	2 (6)	3	4	1 (5)	2 (6)	3	4
Firing Order	1	8	4	3	6	5	7	2

(2) two Coil DFU's  
 Phase Sequential



**Figure 35.** Typical GM 8-cylinder DFU wiring. Firing Order 1-8-4-3-6-5-7-2 depicted here. Remember, 8-cylinder setups fire the coil channels in the order of A<sup>1</sup>-A<sup>2</sup>-B<sup>1</sup>-B<sup>2</sup>.



**Figure 36.** 2-Rotor (Mazda 12A and 13B) coil setup. 4 of these coils will be required for leading and trailing plugs.

Leading plugs will go to **TECgt200** connector pin [2] (white wire) = first rotor, leading. **TECgt200** pin [3] (red wire) = second rotor, leading.

Trailing plugs will go to **TECgt200** pin [14] (white wire) = first rotor, trailing. **TECgt200** pin [15] (red wire) = second rotor, trailing.

## 4.6.6 Common Firing Orders

→ Remember, coils are fired in the following sequence:

- 4 cylinder: A-B-A-B
- 6 cylinder: A-B-C-A-B-C
- 8 cylinder: A1-A2-B1-B2-A1-A2-B1-B2

The following Firing Orders apply to Even-Fire Engines ONLY!

		DFU	DFU	DFU	DFU
		1	2	1	2
		coil	coil	coil	coil
		A	A	B	B
<b>8 cylinder - 2 DFU's</b>	<b>Firing Order</b>				
Most GM, Chrysler, & AMC V8's:	1-8-4-3-6-5-7-2	1&6	8&5	4&7	3&2
Chevrolet LS1 V8:	1-8-7-2-6-5-4-3	1&6	8&5	7&4	2&3
Ford 5.0L, 351W/M/C, 400 V8's:	1-3-7-2-6-5-4-8	1&6	3&5	7&4	2&8
Ford other V8's:	1-5-4-2-6-3-7-8	1&6	5&3	4&7	2&8
Ford 4.6/5.4 Liter V8:	1-3-7-2-6-5-4-8	1&6	3&5	7&4	2&8
Cadillac 368, 425, 472, 500:	1-5-6-3-4-2-7-8	1&4	5&2	6&7	3&8
Cadillac Northstar:	1-2-7-3-4-5-6-8	1&4	2&5	7&6	3&8
Audi 4.2 V8, & Mercedes Benz:	1-5-4-8-6-3-7-2	1&6	5&3	4&7	8&2

		Coil		
		A	B	C
<b>6 cylinder - 3 coil DFU</b>	<b>Firing Order</b>			
Buick 3.0 & 3.8 (60° V6):	1-6-5-4-3-2	1&4	6&3	5&2
Chevrolet 2.8 (60° V6):	1-2-3-4-5-6	1&4	2&5	3&6
Chevrolet 4.3 (90° V6):	1-6-5-4-3-2	1&4	6&3	5&2
Ford 2.8 (60° V6):	1-4-2-5-3-6	1&5	4&3	2&6
Chrysler Slant 6:	1-5-3-6-2-4	1&6	5&2	3&4
Porsche Flat 6:	1-6-2-4-3-5	1&4	6&3	2&5
Datsun Inline 6 (L6):	1-5-3-6-2-4	1&6	5&2	3&4
Nissan 3.0 V6 (60° V6):	1-2-3-4-5-6	1&4	2&5	3&6
VW VR6 (15° V6):	1-5-3-6-2-4	1&6	5&2	3&4

		A1	B1	C1	
<b>6 cylinder - 2 - 3 coil DFU's</b>	<b>Firing Order</b>				
Porsche Flat 6:	1-6-2-4-3-5	1&4	6&3	2&5	Uppers
		<b>A2</b>	<b>B2</b>	<b>C2</b>	
		1&4	6&3	2&5	Lower

		Coil	
		A	B
<b>4 cylinder -</b>	<b>Firing Order</b>		
Most Inline 4-cyl Engines:	1-3-4-2	1&4	3&2
VW Flat 4 (air-cooled):	1-4-3-2	1&3	4&2
Dual Plug 4-cyl:	1-3-4-2	1&4	3&2

#### 4.6.7 How to find the TDC Event Order :

1. Turn the engine to TDC #1.
2. Rotate the engine in its normal direction of rotation.
3. Record the order in which the cylinders have TDC's. It does not matter that the TDC events are mixed between compression and exhaust during this process.

#### 4.6.8 TDC Tooth for DFU "2" needed for an Odd-Fire Engine:

1. Turn the engine to TDC #1.
2. Measure the crankshaft degrees between TDC #1 and the next TDC event for the engine.
3. Take this Degree Number (**DN**) and divide it by 6. If the result has a decimal, round UP to the nearest Whole Number (**WN**).
4. Add WN to the number 11 to give you the necessary value for the **TDC Tooth for DFU "2"** parameter.
5. Perform the following subtraction:  $DN - WN = X$ .
6. Enter **X** into the **Rotary Ignition Split** table for all RPM points.

#### 4.6.9 Harley-Davidson Applications

The unique sound of the Harley-Davidson V-Twin is the result of an odd (uneven) firing pattern between the two cylinders. To run this engine, select **2-cylinder Odd-Fire** for the engine setup. Since this is a 45° V-Twin with one connecting rod lobe, the TDC events occur in the following fashion for one complete engine cycle:

**TDC A – 45° – TDC B – 315° – TDC A – 45° – TDC B**

- For the TDC Setup,
  - Set the DFU #1 Trigger Wheel TDC to the 11<sup>th</sup> tooth.
  - Set the DFU #2 Trigger Wheel TDC to the 18<sup>th</sup> tooth.
- In the **Dual Plug Timing Split**, set the values to 3 degrees for all RPM's.
- Wire DFU #1 - **Coil A1** output to **pin A** of a 4-cylinder DFU. This will fire cylinder A's spark plug.
- Wire DFU #2 - **Coil A2** output to **pin B** (not pin C!) of a 4-cylinder DFU. This will fire cylinder B's spark plug.
- For Phase-Sequential Fuel Operation, wire both injectors to channel 1.

#### 4.6.10 Rotary Engines

For rotary engines, the coil firing occurs on both the leading and trailing spark plugs. Using the **Dual Plug Timing Split Table**, simply enter the desired split (in degrees) between the leading and trailing spark plugs. For a 2-rotor engine, 4 single tower coils will be needed. References to DFU #1 in the software will correspond to the 2 primary spark plug coils (coil

outputs A1 and B1), and will fire the **leading spark plugs** on rotors 1 and 2, respectively. References to DFU #2 in the software will correspond to the 2 secondary spark plug coils (coil outputs A2 and B2), and will fire the **trailing spark plugs** on rotors 1 and 2, respectively. Typically, rotaries work well with about 7-15 degrees of split between the leading and trailing ignition under light load. Under full load, the engines generally make best power with closer to zero degrees of split. A rotary will run on just the leading or trailing ignition, but a power loss will occur. Keep this in mind when trying to diagnose ignition wiring problems.

#### **Rotor 1**

Leading: Coil Channel A1

Trailing: Coil Channel A2

Coil Channel A1 and A2 are split by the value in the Dual Plug Timing Split.

#### **Rotor 2**

Leading: Coil Channel B1

Trailing: Coil Channel B2

Coil Channel B1 and B2 are split by the value in the Dual Plug Timing Split.

### **4.6.11 Dual Plug Engines 4 & 6 cylinder only**

For dual plug engines, there are two spark plugs per cylinder. Although it may seem that you should connect both towers of one coil to the two spark plugs of one cylinder, this is NOT the case. Doing so would require one coil to fire two spark plugs that are on the compression stroke, which would have a very negative effect on spark energy. Instead, the coils must be wired so that each cylinder will have two coils for its two spark plugs. Refer to the example of the 6-cylinder Porsche Dual Plug engine to see how the wiring should be done.

Since most dual plug cylinder heads have a hemispherical design, the spark for both plugs on an individual cylinder should occur at the same instant for optimum flame-front propagation. However, with non-hemispherical dual plug heads, it may be desired to experiment with staggering the spark timing from one plug to the next. To do this, the Dual Plug Timing Split Table can be used. The values entered into this table represent the timing split (in degrees) between the two spark plugs on a particular cylinder. When this is done, the flame front will begin at different areas of the cylinder at different times, resulting in an uneven flame propagation. Consequently, it is recommended that most dual plug applications NOT use the Dual Plug Timing Split.

### **4.7 Spark Plug Wire Selection**

The **TECgt200** outputs an extremely high-energy charge for the ignition coils. Resistor (carbon) core wires work best with this charging method, since they absorb electrical noise generated by the coil firing events. Use 8mm or larger RFI and EMI suppression wire with GM boots. We recommend using a carbon core-style suppression wire with a resistance of 3,000 to 5,000 ohms per foot. **SOLID CORE WIRES SHOULD NEVER BE USED.** Do not be misled by spark plug wire manufacturers claiming to give you a "power increase" from their wire. The bottom line is that with our charging method, different spark plug wires simply do not make a difference in terms of spark energy. However, there is a huge difference in noise generated by different spark plug wire types (solid core wires generate a very high amount of noise with our system).

**Quoted from Magnecor's Website:**

“What is not generally understood (or is ignored) is that the potential 45,000 plus volts (with alternating current characteristics) from the ignition coil does not flow through the entire the length of fine wire used for a spiral conductor like the 1 volt DC voltage from a test ohmmeter, but flows in a magnetic field surrounding the outermost surface of the spiral windings (skin effect). The same skin effect applies equally to the same pulsating flow of current passing through carbon and solid metal conductors. A spiral conductor with a low electrical resistance measured by a 1 volt DC ohmmeter indicates, in reality, nothing other than less of the expensive fine wire is used for the conductor windings!

Electrical devices, including spark plugs, use only the electrical energy necessary to perform the function for which such devices are designed. Spark plug wires are nothing more than conductors, and whereas a bad ignition wire's inefficient conductor can reduce the flow of electricity to the spark plug, an ignition wire that reportedly generates an "increase" in spark energy will have no effect on the spark jumping across the spark plug gap, since the energy consumed at the spark plug gap won't be any more than what is needed to jump the gap. For a more obvious example of this, a 25watt light bulb won't use any more energy or produce any more light if it's screwed into a socket wired for a 1000watt bulb.”

Due to the extremely high energy in the **TECgt200** coil charging circuit, spark plug wires may wear out faster than with a standard ignition. As such, it is recommended that the wires be checked periodically for carbon tracking caused by a breakdown of the internal conductor element. Looking at the plug wires in a dark area and wetting them with a spray bottle of water will reveal carbon tracking. Pay close attention to the exposed section of the spark plug (where the rubber boot ends) during the test. To maximize spark plug wire life, keep the lengths as short as possible (i.e. mount the DFU as close to the engine as possible). Replacement of the wires on an annual basis is recommended for high-rpm/high-horsepower applications.

For an extremely high-quality wire with excellent noise suppression, we recommend the Magnecor brand. Specifically, their “Electrosports 80” 8mm wire is very good with our system. Custom wire lengths and ends are available from them so you will not need to crimp the wires yourself. They can be reached at (248)669-6688 or on the web at: [www.magnecor.com](http://www.magnecor.com) . Taylor Pro-Wire Silicon Resistor wires also work well.

## 4.8 Spark Plug Selection

As was previously stated, spark plugs are generally more important to spark quality than spark plug wires. Most spark plugs exhibit failure when exposed to a large load. Failure usually consists of either intermittent sparking or arc-over. Arc-over is when the spark occurs between the spark plug wire and the engine block, instead of at the plug tip. Arc-over is exacerbated by the use of low-quality wires, or wires that have cuts in the insulation.

The load at which a spark plug fails is different for all spark plugs. With the **TECgt200's** charging circuit, the more load you put on an engine, then more voltage will be applied to the plug. This is a beneficial situation: for a high compression engine, the voltage at the plug will be inherently higher (since there is more load). The detriment is that spark plugs and wires are only rated to a certain voltage (30-40,000 volts is typical), and can begin to “blow out” at around 40,000 volts. If that voltage is exceeded by a large amount for a long enough length of time, the spark plugs will either blow out, break down or arc to somewhere other than the electrode (often through the insulator directly to the engine block).

The solution is to run smaller plug gaps on high-compression engines. This is perfectly acceptable with our ignition charging method, since the high load of the cylinder pressure will allow the voltage to be quite high at the electrode, but the small gap will keep the plug from seeing an over-voltage situation. Use the recommendations below as a guideline for spark plug gaps:

- Stock Street Engine 0.045”-0.060” (1.1mm-1.5mm)
- High Performance Street 0.030”-0.035” (.75mm-.9mm)
- Alcohol High Compression 0.025” (0.65mm)

- High Power 75 -115 HP per Cylinder 0.025" (0.65mm)
- Over 115 HP per Cylinder 0.022" (0.55mm)
- Over 12:1 CR or Over 14psi Boost 0.022" (0.55mm)

Use of resistor plugs is highly recommended for optimum noise suppression. If using anything other than a resistor spark plug wire, a resistor plug **MUST** be used. The bottom line is this: the **TECgt200** system uses an *inductive* (long duration charge at battery voltage) charging method for the coils, which is completely different than the *capacitive* (short duration charge at higher-than-battery voltage) charging method used by several other aftermarket manufacturers. What may work well for these systems may not work well for ours. Following our recommendations about spark plug and wire selections will yield excellent results.

## 4.9 Driver on Coil Logic Driven Coils

If you select Driver on Coil logic driven coils you will not use the shielded wires found on pins [1,2,3,4 and 13,14,15,16]. Remove or tape these wires off. The DOC logic level outputs are very sensitive to miss wiring. Be careful not to short these wires to ground or +12V. Internal damage will happen if you do. The DOC logic outputs are +5 volt logic and cannot drive coils directly. It is allowed to connect up to two DOC coils to each logic output.

DOC coils either are 3 or 4 wire devices.

	Connect To:	3 wire DOC	4 wire DOC
Power +12 V	DFU Power +12V Switched	+12V	+12V
Signal	Pin 5, 6, 7, 10, 11 or 12	Signal	Signal
Power Ground	Engine Block Ground	Ground	Power Ground
Reference Ground	Pin 17 or 18 Black/White	Not Present	Reference Ground

The wiring of the logic signals simply follows the plug wiring as noted in the standard DFU wiring above. Where a coil spark plug wire connection is indicated substitute the DOC logic output for that cylinders DOC coil. One DOC logic output is wired to two DOC coils.

### SIGNAL CONNECTION EXAMPLES: VERIFY THE FIRING ORDER

		4 Cylinder	6 Cylinder and Dual Plug	8 Cylinder
	Firing Order:	1-3-4-2	1-6-2-4-3-5	1-8-4-3-6-5-7-2
<b>Standard Coil</b>	<b>DOC Pin / Wire Color to signal pin</b>	<b>Connect to Coils</b>	<b>Connect to Coils</b>	<b>Connect to Coils</b>
A1	5 Black/Gray	1 and 4	1 and 4	1 and 6
B1	6 Black/Red	2 and 3	3 and 6	4 and 7
C1	7 Black/Green	Not Used	2 and 5	Not Used
A2	10 Black/Blue	Not Used	1 and 4 (dual plug)	5 and 8
B2	11 Black/Pink	Not Used	3 and 6 (dual plug)	2 and 3
C2	12 Black/Orange	Not Used	2 and 5 (dual plug)	Not Used

When using the DOC logic outputs, tape up or remove the unused standard coil outputs.

**WARNING:** Before starting the engine when DOC coils are used, change the engine configuration setting to DOC coil and set a fixed dwell time. If you do not know the exact dwell time to use for the coil you have, start with 1.8 mSec. Failure to make this calibration change may cause extreme damage to the coils.



## 5 Wiring Sensors & Other Inputs

The **TECgt200** harness has provisions to connect all of the engine devices described in this section. Refer to this section to wire your sensors appropriately.

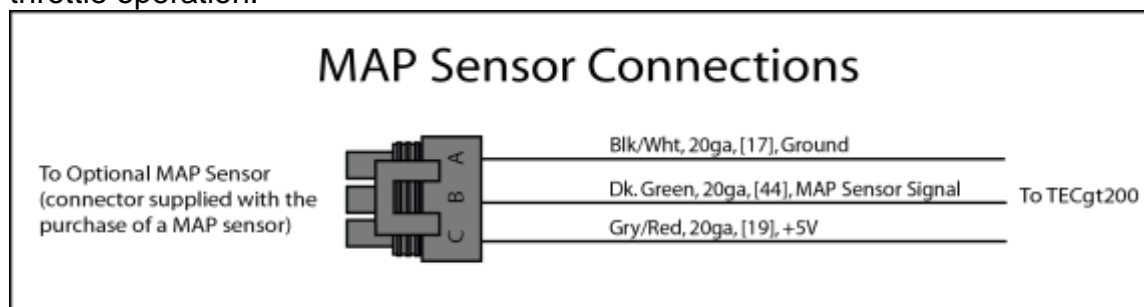
- The following sensors use pull-to-seat connectors (feed the wire through the connector before crimping the terminal!):
  - Coolant Temperature
  - Manifold Air Temperature
  - Some Throttle Position Sensors
  - Idle Air Control Motor
- The following sensors use push-to-seat connectors (crimp the terminal to the wire before inserting into the connector!):
  - Crank Sensor
  - Cam Sensor (if used)
  - MAP sensor (1-Bar sensors use green connector. 2-& 3-Bar use orange connector)
  - Some Throttle Position Sensors
  - EGO Sensor
  - Knock Sensor

### 5.1 The Manifold Air Pressure (MAP) Sensor

The MAP sensor determines the operating load of the engine. To do so, it measures the intake manifold absolute pressure. Since the intake manifold pressure has a direct effect on the amount of air that the cylinders can ingest, the use of a MAP sensor as a load-determining device is well justified.

MAP sensors are available from Electromotive in three varieties: 1-, 2-, and 3-Bar. A 1-Bar sensor would be used on a naturally aspirated engine, a 2-Bar sensor would be used on a boosted engine (up to 15psi), and a 3-Bar sensor would be used on a boosted engine (up to 30psi).

The output of a MAP sensor is a 0 to +5 Volt signal. When the intake manifold pressure is low (high vacuum), the sensor reading is low (approaching 0 Volts). This would occur during part-throttle cruising or decelerating (engine braking). When the intake manifold pressure is high (low vacuum), the sensor reading is high (approaching +5 Volts). This would occur during full throttle operation.



**Figure 40:** MAP sensor wiring.

## 5.1.1 MAP Sensor Data

To check that the MAP sensor is working correctly, and to check for the MAP sensor Bar number (1-, 2-, or 3-Bar), it is necessary to know the output voltage from the sensor as a function of pressure. With the **TECgt200** turned on, but the engine NOT running, the MAP sensors will output the voltage for atmospheric pressure (since manifold pressure is equal to the atmospheric pressure when the engine is not running). At standard atmospheric conditions (101.3 kPa), the output voltages should be:

- 1-Bar: approximately 4.80 Volts
- 2-Bar: approximately 2.30 Volts
- 3-Bar: approximately 1.55 Volts

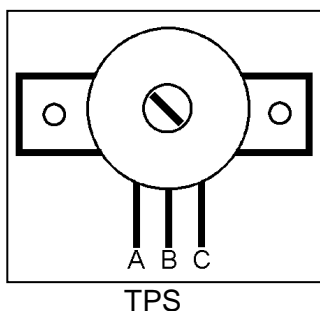
Note that the output voltage should be measured between pin “B” (output) and pin “A” (ground). If the sensor does not output a voltage near the above numbers, the sensor is likely defective. Refer to **Figure G.1.1** for MAP sensor wiring instructions. Refer to **Figures G.1.2 through 4** for MAP sensor voltage as a function of manifold pressure for the three MAP sensors.

## 5.2 Throttle Position Sensor

The throttle position sensor (TPS) functions as a multi-purpose input to the **TECgt200**. TPS's that are compatible with the **TECgt200** must be of the potentiometer (rheostat) variety. A potentiometer has three connections: +5Volt, Ground, and Output Signal. As the throttle is moved, the TPS output should transition smoothly from a low voltage (approaching 0V) at idle to a high voltage (approaching 5V) at full throttle. Switch-type TPS's will NOT work with a **TECgt200** since they do not output a smooth voltage transition from closed to opened throttle.



The throttle position sensor should have a resistance of roughly 10k $\Omega$  measured across the +5V and Ground terminals. To determine the pin out of an unknown TPS, follow the instructions below (you will need an ohmmeter):



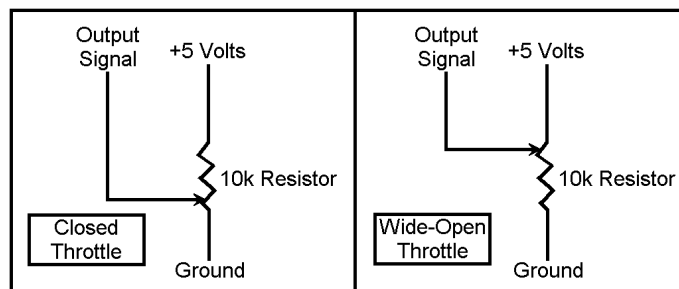
1. With the TPS in the **closed throttle** position, measure the resistance of the following three positions referenced to **Figure G.2.1**: A-B, A-C, and B-C.
2. With the TPS in the **opened throttle** position, measure the same three resistances. Two of the readings will have changed from Step 1, and one of the readings will be the same.
3. The +5V and Ground terminals are from the terminal pair whose resistance stayed the same between steps 1 and 2. The **Ground** terminal is from the pair whose resistance *increased* from Step 1 to Step 2.

**Example:** **Step 1.** Closed Throttle: A-B : ~500 $\Omega$  B-C : ~9500 $\Omega$  A-C : ~9500 $\Omega$   
**Step 2.** Opened Throttle : A-B : ~9500 $\Omega$  B-C : ~500 $\Omega$  A-C : ~9500 $\Omega$   
**Step 3:** Process of Elimination

- A-C resistance stayed the same in steps 1 & 2. Therefore, either “A” or “C” is the Ground connection.

- A-B resistance increased from  $\sim 500\Omega$  to  $\sim 9500\Omega$  from Step 1 to Step 2. Therefore, “A” or “B” is the ground connection.
- **“A” must be the Ground** connection since “B” cannot be the ground connection as a result of Step 1.
- **“C” must be the +5 Volt** connection, since “A” is not.
- **“B” must then be the Output Signal.**

Another way to look at the TPS’s electrical functionality is to realize that it simply creates an output that is either biased to Ground or to +5 Volts. At closed throttle, the output should be biased to ground, and at full throttle, the output should be biased to +5 Volts. See **Figure 41** for an electrical schematic of a typical potentiometer. Please note that the TPS must use a (roughly) 10k $\Omega$  potentiometer! Failure to do so will result in improper impedance matching for the **TECgt200**, and a false sensor reading will result. Fortunately, most TPS’s are of the 10k $\Omega$  variety.



**Figure 41** Potentiometer functionality for closed and open throttle conditions.

### 5.3 TPS Functionality and Wiring

The TPS allows the **TECgt200** to provide fuel enrichments for various throttle movement situations, like an accelerator pump on a carburetor. For high rpm, closed throttle situations, (like deceleration or engine braking), it can be used to turn off the fuel flow completely. The TPS is also used to detect closed throttle for the activation of the Idle Air Control parameter. See **Tuning Guide and Fuel Injection Section** for tuning the TPS-related functions.

Many different TPS’s have been used by OEM’s in the past few decades. The most common types are driven directly on the throttle shaft by either a dowel pin going through the shaft of a “D” shaped throttle shaft. Various TPS styles are available from Electromotive, as outlined in **Figures 42 to 45**.



Arm-Style TPS  
PN 310-71310

**Fig. 42**



GM Dowel-Pin Style  
PN 310-71320

**Fig. 43**



“D” Shaft TPS  
PN 310-71340

Fig. 44

Ford Dowel-Pin Style  
PN 310-71330



Fig. 45

The TPS connects to three wires from the **TECgt200** harness: +5 Volt, Ground, and TPS Signal. See **Figure 46** for proper wiring instructions.

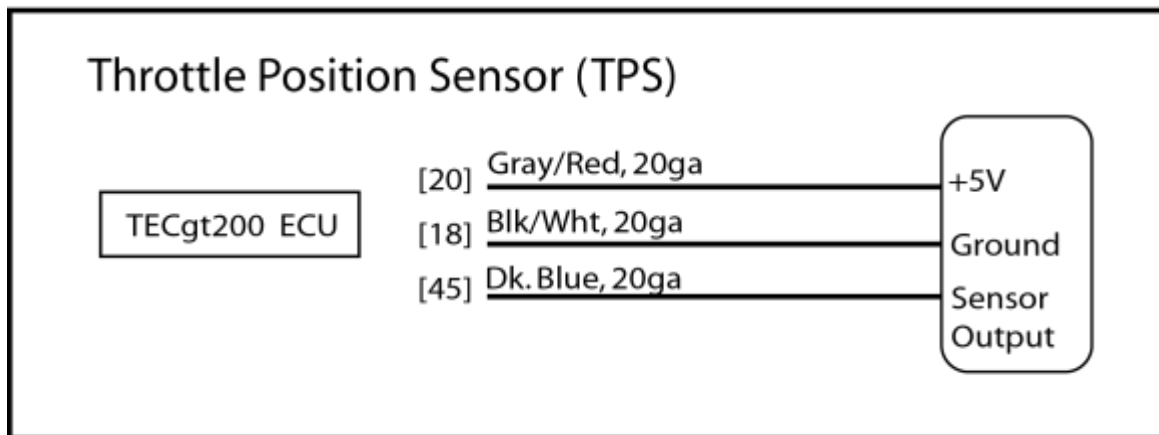


Figure 46: Proper throttle position sensor wiring

## 5.4 Coolant Temperature Sensor

The **TECgt200** is compatible with negative temperature coefficient (NTC) thermister-type coolant temperature sensors. This type of sensor has two terminals, and the resistance between the two terminals changes as a function of temperature (see **Figure 50**). The coolant (CLT) sensor provides variable fuel enrichment as a function of engine temperature. Tuning the CLT-Based enrichments is covered in the Tuning Section.

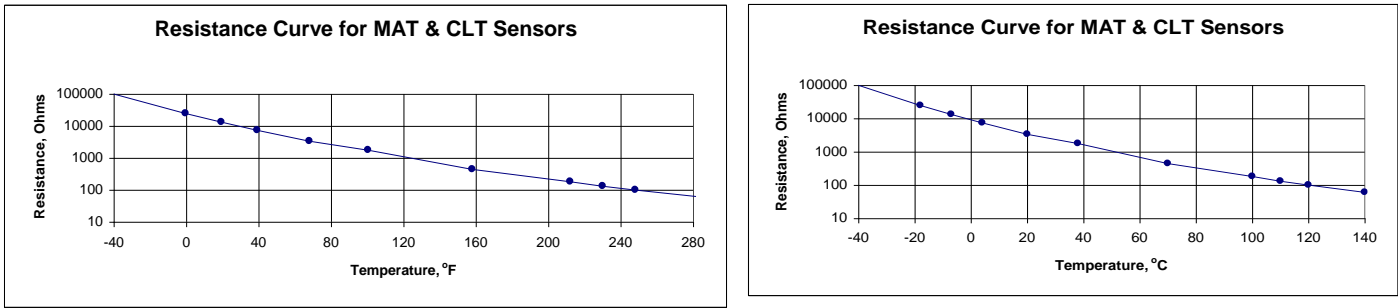
The **TECgt200** is set up to use the GM-style coolant temperature sensors. These sensors are sold by Electromotive under part number 305-71210. They are threaded for a 3/8" NPT hole.

**Liquid-cooled** engines should have the CLT sensor installed somewhere in the coolant passages. Ideally, it should be installed toward the outlet of the engine (or the entry of the radiator) so that the highest temperature reading will be seen.

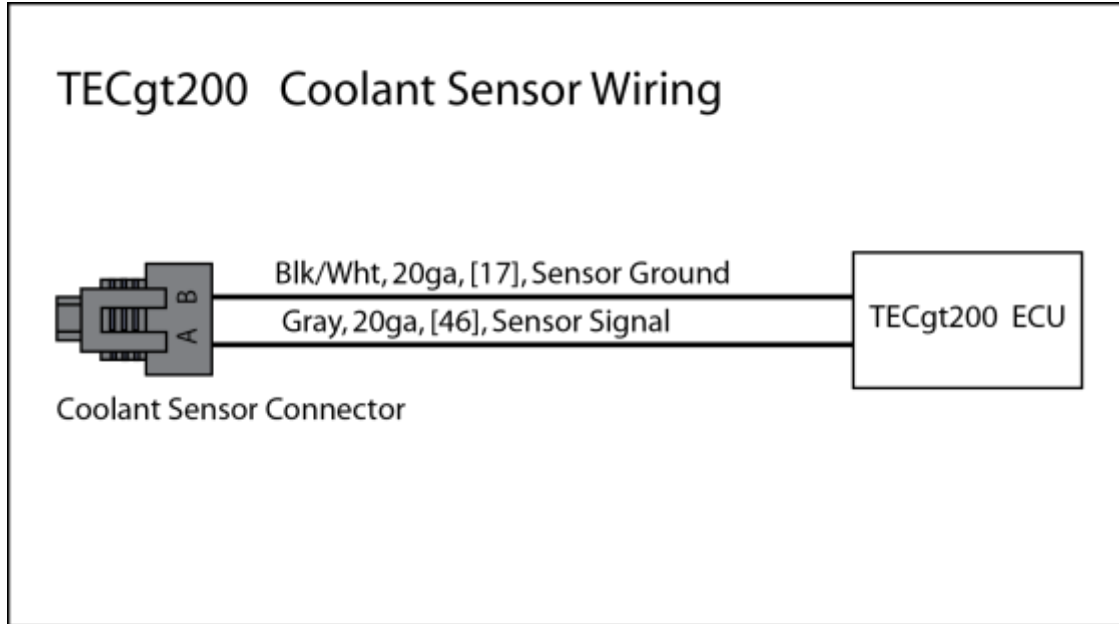
For **air-cooled** engines, there are a few options for obtaining a usable engine temperature. The first option is to use the factory cylinder temperature sensor, which is often found on air-cooled Porsche applications. The second option is to use the engine oil temperature instead of the coolant temperature. Beware of choosing this method, since air cooled engines often have a



very large oil capacity that takes much longer to heat up than the cylinders themselves. A third option would be to use a *manifold air temperature* sensor in a sheet metal “stove” on one of the cylinders.



**Figure 50.** Sensor resistance vs. temperature for CLT and MAT sensor.



**Fig. 51.** Coolant temperature sensor wiring.

Wiring the Coolant temperature sensor is straightforward. See **Figure 51** for details. Since the sensor is just a resistor, wires “A” and “B” can be switched with no adverse results.

To test for faulty coolant temperature sensors, simply measure the resistance across terminals A and B with an ohmmeter. Match the resistance of the sensor to the operating temperature using **Table 5**. As a guideline, use the following specs:

- Cold engine (70F, 20C): ~3300Ω
- Hot Engine (180F, 80C): ~350

**Table 5.** CLT and MAT sensor resistance

Temp, °C	Temp, °F	Resistance, ohms
-40	-40	100700
-18	0	25000
-7	19	13500
4	39	7500
20	68	3400
38	100	1800
70	158	450
100	212	185
110	230	133
120	248	102
140	284	62

## 5.5 Manifold Air Temperature Sensor

Like the Coolant Temperature Sensor, the Manifold Air Temperature (MAT) Sensor is an NTC thermister. The MAT sensor allows fuel enrichments for varying inlet air temperatures. This is useful because cold air is denser than warm air, and as a result, cold air needs more fuel. Tuning the MAT Sensor enrichments is covered in **Tuning Section** of this manual.

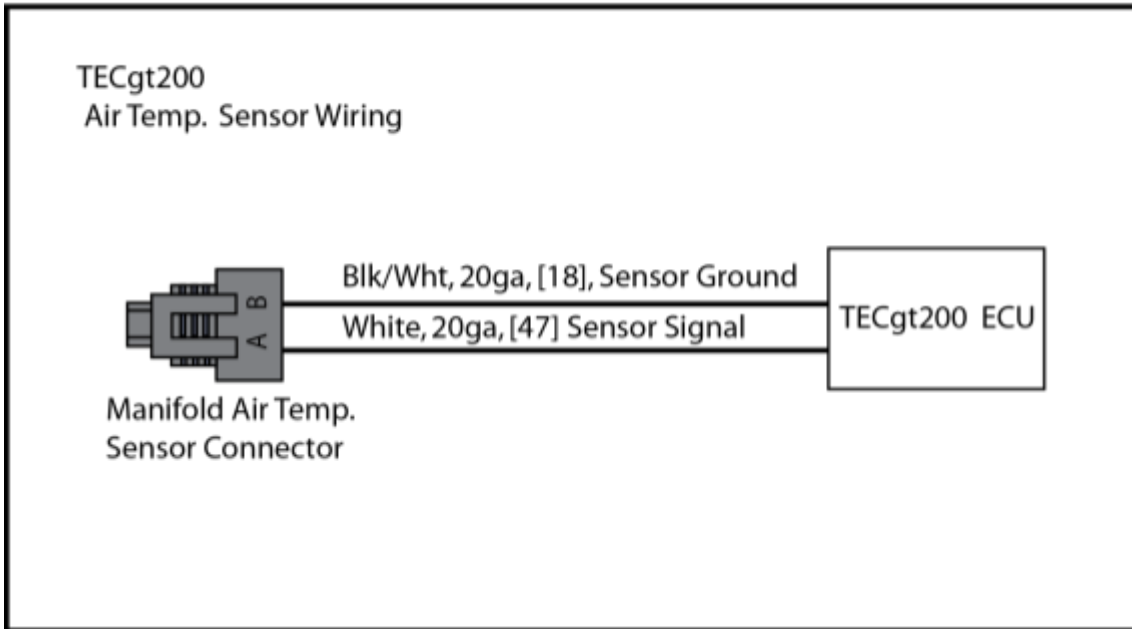
The **TECgt200** is set up to use the GM-style MAT sensors. These sensors are sold by Electromotive under part number 305-71220. They are threaded for a 3/8" NPT hole. Wiring the MAT sensor is very easy. See **Figure 52** for details.

Install the MAT sensor in an area that is representative of the air temperature entering the engine. If it is mounted directly in the intake manifold (particularly in aluminum and iron manifolds), it may be getting a slightly warmer reading than the actual air temperature due to the conduction of heat through the manifold and the radiation of heat onto the sensor tip. It is sometimes better to install the sensor upstream a bit, particularly if the air intake (or filter box) is made of a material that does not conduct heat very well (like plastic). This will give the MAT sensor a more appropriate reading for intake air temperature.

The MAT sensor resistance curve is identical to that of the CLT sensor. See **Figure 50 and Table 5** for details. The sensor resistance test can be done the same way as well:

70°F (20°C):       ~3300Ω  
180°F (80°C):       ~350Ω





**Figure 52.** Manifold air temperature sensor wiring.

## 5.6 The Exhaust Gas Oxygen Sensor

The Exhaust Gas Oxygen (EGO) sensor is designed to measure the oxygen content of the combustion products. In measuring this value, an estimate of an engine's air-to-fuel ratio (AFR) can be made. **The Fuel Injection / Oxygen Sensor Corrections Section** covers the functionality and tuning of the EGO sensor.



### 5.6.1 Mounting the EGO Sensor

The EGO sensor should be mounted in the exhaust stream close to the engine. It should not be mounted in the header pipe for only one cylinder. Instead, it should be mounted after the collector. Failure to mount the EGO sensor close to the engine will result in poor performance due to under-heating the sensor. The EGO sensor needs plenty of heat to operate properly. Mild steel threaded bungs for the EGO sensor are available from Electromotive under PN 315-72111.

When installing the sensor, take care not to run the wires on the exhaust. This will obviously melt the wires once exhaust temperatures rise.

### 5.6.2 Wiring the EGO Sensor

Virtually all 4-wire EGO sensors on the market are compatible with the **TECgt200**. Most universal EGO sensors available from the auto parts store have a color code as follows:

Black: EGO +  
 Gray: EGO –  
 White: Heater + or –  
 White: Heater – or +

- Note that the heater polarity is not important, it only needs opposite voltages on the two wires. **DO NOT ATTEMPT TO RUN THE EGO HEATER WITH THE +5V LINE IN THE TECgt200 HARNESS!!**

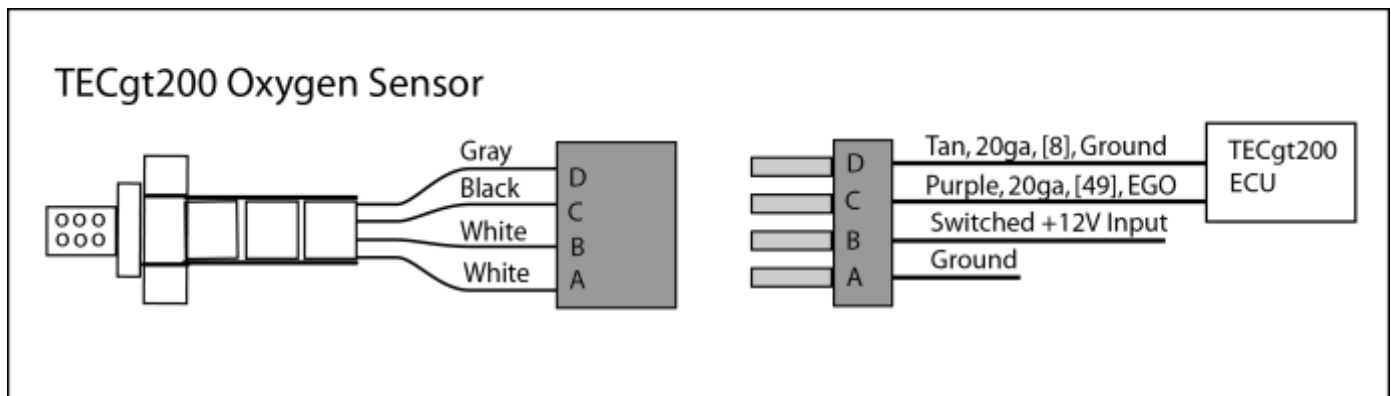


Electromotive's EGO sensors also follow this color code, and are mated to a 4-position female weather-pack connector in the following pin out:

Gray: Pin D    Black : Pin C    White : Pin B    White : Pin A

The heater circuitry allows the EGO sensor to warm up quickly. It also keeps the EGO as warm as possible during idling conditions, where unheated EGO sensors (1-wire style) often cool down significantly. The positive wire for the heater can be spliced to the Fuel Pump output on the **TECgt200** Power Harness (PN 070-40000). This is the 16awg light green wire. This is NOT the same as the Fuel Pump Relay Ground output of the **TECgt200**, which is a 20awg light green wire from pin [57].

If the Power Harness for the **TECgt200** is not being used for the EGO heater element, the EGO heater should be wired to a switched voltage source. If it is wired to a full-time voltage source, it will drain the battery in short order! See **Figure 56** for proper wiring.



**Figure 56.** Wiring details for Electromotive's EGO sensor (PN 315-72120).

### 5.6.3 EGO Functionality

When using an EGO sensor, it must be realized that AFR's that are not near the stoichiometric value are not accurate. The stoichiometric value is the AFR that results in complete combustion with no excess fuel (gas, alcohol, etc.) or excess air (oxygen). In simple terms, the stoichiometric value is AFR at which the incoming mixture is neither **lean** nor **rich**. Read the section on Oxygen Sensor Corrections for more information.

The reason for inaccuracies when away from the stoichiometric AFR is simple: EGO sensors are only designed to provide a **switch-point** at the stoichiometric AFR. The voltage goes from a low reading (approaching 0 volts) when lean to a high reading (approaching 1 volt) when rich. Note that the **TECgt200** software multiplies the EGO input voltage by a factor of 5 when displayed on the engine monitor and datalog screens. Thus, the maximum value that could be obtained for a rich mixture would be 5volts, not 1volt. Instead of being a straight line between lean and rich, the curve is like the one depicted in **Figure 98**. Additionally, the EGO curve changes with exhaust gas temperature, thus nullifying calibration data made at a particular exhaust temperature when used at a different temperature.

Along with these negatives comes a positive: an EGO sensor is typically good at providing a stoichiometric measurement when at idle or part-throttle cruising. When the EGO sensor is turned on (as in closed loop mode), it will try to correct the AFR reading to the values defined in the Desired Air Fuel Ratio Table. It does this by manipulating the fuel injector pulse width. When the EGO sensor is turned off (as in open loop mode), the reading from the EGO is still present, but the sensor is not trying to obtain the values in the Desired Air Fuel Ratio Table.



It is recommended that the EGO sensor be used for its intended purpose: to provide a stoichiometric measurement. Consequently, the EGO should be run in closed loop mode only when the engine should be operating at the stoichiometric mixture. Medium and high load situations **MUST** be run richer than stoichiometric to prevent engine damage, thus the EGO should be in open loop when these circumstances are met. Many choices are available in the software to keep the EGO sensor in the correct mode (closed or open loop) at the correct time (low or high load, etc.).

A small, but important, fact concerning the EGO operation is that when a coolant-temperature enrichment is in place, the target Air-Fuel Ratio will be altered from the reading in the Desired Air Fuel Ratio Table. The target Air Fuel Ratio is changed by the following equation:

$$\text{Target AFR} = \text{Desired AFR Table Value} - [4.34 \times (\text{Coolant Enrichment \%} \div 100)]$$

Therefore, when a 10% Coolant Temperature Enrichment is in the Coolant Enrichment Table, the target AFR would be about 14.2:1 if the Desired Air Fuel Ratio Table value was 14.64:1.

### 5.6.4 About One-Wire EGO Sensors

One Wire EGO sensors were used a number of years ago on early fuel-injected vehicles (and some carbureted engines). These EGO's output the same voltage curve as any standard 4-wire sensor, but do not have a built-in heater or ground reference. Wire the sensor as follows:

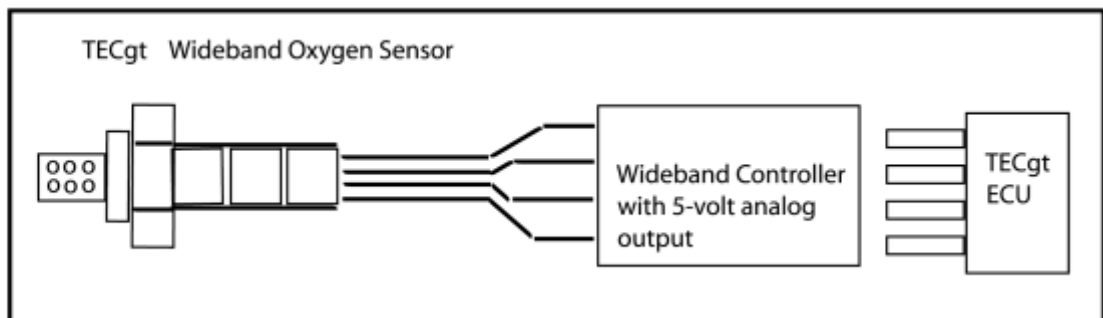
- Connect the wire from the EGO sensor to the EGO+ line on the **TECgt200** (this is the Purple 20awg wire in the **TECgt200** Harness – Pin [49]).
- Connect the EGO- line on the **TECgt200** (this is the tan 20awg wire going to Pin [8]) to the Sensor Ground line (this is black w/ white stripe 18awg wire going to ground).

One-wire sensors are typically not as accurate as 4-wire sensors, since they have no built-in heater element. Instead they must rely on exhaust system heat entirely. Unless the EGO sensor is mounted very close to the engine in a cast iron manifold, 1-wire sensors should not be used.

## 5.7 Wideband O2 Sensor

### 5.7.1 Wideband EGO Information and Installation Instructions

The **TECgt200** supports an input from most wideband sensor controllers. The wideband controller must have an analog 5-volt output signal. A typical configuration is shown in Figure 57.



**Figure 57-** Typical Wideband Configuration

The installation of the oxygen sensor and controller should follow the wideband controller manufacturer's instructions.

- The analog 5-volt output signal connects to pin [49], O2 sensor (+) (purple wire) on the **TECgt200**.
- The wideband signal ground is connected to pin [8] (tan wire).

\*Note: Some wideband control units have a sensor ground and a ground for the heater. Other units have only one ground. You should connect the sensor ground to G32. If there is only one ground or the controller manufacturer recommends grounding the unit directly to the battery, follow the manufacturer's installation instructions.

To select the wideband input for a calibration file, click the "EGO/Wideband Air/Fuel Ratio Table" button from the Calibration Screen. (Note: this should be performed in No Connection Mode, the bin file should then be saved and downloaded to the **TECgt200**). Then click "Calibrate EGO Sensor". Click "Load WIDEBAND EGO Sensor Table, this effectively performs two operations. The first is it configures the **TECgt200** to use the analog voltage on pin [49] as the EGO voltage. The second is that it loads the default wideband sensor values. Since there are so many different controllers, the default values will probably not exactly match the data provided by your controller's manufacturer. Therefore, it is essential that you use the manufacturer's data to adjust the voltages and AFR's in the boxes provided. Lastly, return to the Calibration Screen, save your bin file, and download it to the **TECgt200**. **You are now ready to use the wideband EGO input.**

## 5.8 Secondary EGO sensor input

A second EGO sensor input is available. Connect this to pin 50, Purple/Tan wire. Use pin 17 or 18 Black/White for the reference ground. This sensor input is used just for data logging and does not control any outputs.

### 5.8.1 EGO FAQ's and Troubleshooting Tips:

1. *"How do I know the **TECgt200** is using the wideband sensor?"*

There are several indications that you are using the wideband option for your EGO input. The label for EGO voltage on the digital monitor screen (the monitor screen at the bottom of the window) will change from "EGO Sensor" to "Wideband Sensor". On the analog monitor screen, the label under the AFR bar will change from "EGO Sensor" to "Wideband Sensor".

2. *"The **TECgt200** AFR changes, but it doesn't match my controller's display unit."*

The analog voltage from the wideband controller can be read on the analog monitor screen in the box labeled "WBS". The **TECgt200** uses this voltage, and the corresponding values you entered in the calibration to determine the AFR. For example, if the manufacturer states 2 volts is an AFR of 12.6, and the **TECgt200** WBS is displaying 2 volts but the **TECgt200** AFR reads 13.6, then you entered the calibration values incorrectly. Repeat the procedure detailed above to correct the calibration file. If the **TECgt200** is displaying the AFR you would expect for the corresponding voltage, but your controller display unit does not match accordingly, then you should contact the wideband controller's manufacturer with this discrepancy.

3. “My EGO seems to be correcting backwards – taking out fuel when lean and adding fuel when rich.”

Return to the EGO Calibration menu and verify that the wideband sensor has been selected. Also verify that you are using the wideband option by looking for the changes in the labels as described in Tip #1. Save your bin file and download it again to the **TECgt200**. Turn the key off, and then back on.

4. “My AFR does not change – ever.”

In the EGO calibration menu verify that your Minimum EGO/Wideband Voltage Before Sensor is Disabled is 0 volts, and the Maximum EGO/Wideband Voltage Before Sensor is Disabled is 5 volts. If they are not, change the values, save your bin file and download it again to the **TECgt200**. Turn the key off, and then back on.

## 5.9 Knock Sensor

To compensate for poor fuel quality and other adverse engine operating conditions, the **TECgt200** has the ability to retard timing based on detonation. To perform this task, it uses a knock sensor to sense when the engine is experiencing spark knock. The knock sensor circuitry in the **TECgt200** is designed to sense **detonation**, not pre-ignition. Pre-ignition occurs when the air/fuel mixture in the cylinder is ignited before the spark plug fires. This is generally the result of a hot spot in the cylinder. When pre-ignition occurs, peak cylinder pressure occurs after the piston has reached top dead center (TDC) of its compression stroke, but too early to produce optimum power. Optimum engine power generally occurs when the peak cylinder pressure is between 10 and 15 degrees after TDC compression. Thus, pre-ignition causes the cylinder pressure to peak before the ideal 10-15 degrees after TDC compression, and in extreme cases, the peak cylinder pressure may occur *before* TDC.



**Detonation** is often referred to as “pinging” or “spark knock.” On many engines, the human ear can easily hear the sound made by detonation, since it occurs in the audible range (typically around 5000 cycles/sec). The knock sensor can hear the onset of pre-ignition as well, but better than our ears.

Detonation is defined as a pressure shock wave that develops in a cylinder as a result of a slow-burning flame front. Typically, detonation is caused by ignition timing that is too advanced, poor fuel quality (low octane), or poor combustion chamber design. Engines with large combustion chambers and poor air-swirl characteristics are especially prone to detonation. During detonation, the spark plug initiates the flame front, but the flame front moves so slowly that there is time to compress and heat the unburned mixture to the point of *spontaneous ignition*. This results in a pressure shock wave that is akin to beating the upward-moving cylinder with a downward-moving hammer! It also results in a noise resonance through the engine block, just as a noise would resonate through the block if you hit the piston with a hammer. Piston, ring, and rod bearing damage is typical when an engine is detonating too much.

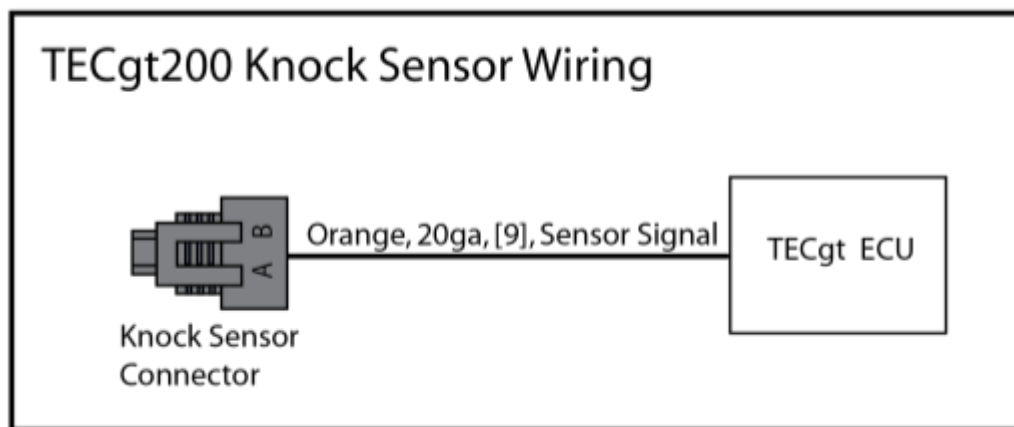
To obtain an accurate reading, the knock sensor must be screwed into the engine block. A plugged hole in a coolant passage is an ideal location, since the knock sensor is threaded for a 1/4" NPT hole. The knock sensor is essentially a microphone that is designed to be very sensitive to the frequency of detonation.

When the **TECgt200** senses detonation from the knock sensor, it will begin to retard the timing on all subsequent spark events. Once knock has dropped a sufficient amount, the timing will then begin to increase to the desired advance setting. When the **TECgt200** starts to increase the advance, it will not add any more timing than what is set in the Ignition Advance table.

Since engines are more likely to experience detonation at lower RPM's with medium or high loads, it is advisable to turn the knock sensor on for these conditions. On the other hand, since engines are less likely to experience detonation at higher RPM's (since the flame front is moving too fast for detonation to occur), AND most engines will increase their mechanical noises that can false-trigger the knock sensor (like valves hitting their seats), it is advisable to turn the knock control off at high RPM's. Mechanical noise can be identified by datalogging a light-load, high-RPM driving situation. If no detonation is heard during the drive, but the datalog indicates that there was knock in the upper rpm/light load area, mechanical noise may be false triggering the knock sensor.

Rotary engines are generally unable to use the knock parameter as effectively as a piston engine, since real detonation in a rotary will typically only occur one time...then the apex seals will be broken! It is still worth using the knock sensor on a rotary, but do not place all of your faith in it. Just keep in mind that ignition timing should always be VERY conservative with a rotary engine.

The **TECgt200** uses any 1-wire *FREQUENCY-BASED* knock sensor input. Electromotive stocks a GM 1-wire knock sensor under PN 305-71410. See **Figure 58** for wiring details.



**Figure 58.** Knock sensor wiring.

### 5.10 Auxillary Temperature Sensor Input

A third temperature sensor input is available on pin 48 Orange/White. It is connected just like a coolant temperature sensor. Connect the signal to pin 48 and connect the reference to pin 17 or 18.

This sensor input is just used for data logging and does not control any outputs.

### 5.11 General Purpose Inputs (GPI's)

The General Purpose Inputs (GPI's) are configurable for many different input functions. These are dedicated GPI **input only** channels. Most are analog voltage inputs except "Speed" which is a frequency input.

An analog input is defined as a 0-5 volt signal. TPS, MAP, and EGO sensors are good examples of analog voltage sensors. A speed input is defined as a frequency signal. When using a magnetic sensor as a speed sensor, its output will be an AC sine wave. When using a Hall effect sensor, the output will be a 0-5 volt square wave.

One of the most useful functions of the GPI is trimming. Using a simple potentiometer referenced to +5 volts and ground, it is possible to configure the inputs to trim the fuel and spark curves based on the potentiometer knob position. These functions are quite easily configured in the WinTEC software.

**GPI Wiring Table:**

GPI Input	Pin Color	Function
2	22 Orange/Red	Analog Voltage 0-5 VDC
3	23 Orange/Green	Analog Voltage 0-5 VDC
4	24 Orange/Blue	Analog Voltage 0-5 VDC
5	25 Orange/Purple	Analog Voltage 0-5 VDC
6	26 Orange/Pink	Analog Voltage 0-5 VDC
7	27 Orange/Tan	Analog Voltage 0-5 VDC
8	28 Orange/Yellow	Analog Voltage 0-5 VDC
9	29 Orange/Gray	Analog Voltage 0-5 VDC
Speed	34 Orange/Black	Road Speed Pulses
EG RTD	48 Orange/White	Resistive Temperature Sensor
EGO Sec.	50 Purple/Tan	Analog Voltage 0-5 VDC

**5.11.1 Available General Purpose Input (GPI) Functions**

**Fuel Trim:** Trims the fuel curve by a set amount through the use of a potentiometer. See **Figure 60** for wiring diagram.

**Ignition Advance Trim:** Trims the ignition advance angle by a set amount through the use of a potentiometer. See **Figure 60** for wiring diagram.

**GPO Trim #1 and #2 :** These functions allow the user to add or subtract up to 50 percent Duty Cycle from the values established in the GPO table specified by the trim number. GPO Trim #1 only effects table 1, GPO Trim #2 only effects table 2. See **Figure 60** for wiring diagram.

**A/C Idle Speed Increase:** On **TECgt200** installations with an idle air control motor, this feature allows the idle speed to be increased when the air conditioner is turned on. See **Figures 61 and 62** for recommended wiring.

**Valet Switch:** When a speed input is used, the valet switch allows the user to set a speed limit on the vehicle. The rev limiter will be activated when the desired speed is reached. See **Figure 64** for wiring diagram.

**Nitrous Retard:** Provides a set amount of ignition timing retard when nitrous is activated. When used with the Electromotive 4-stage timing retard module, the NOS Retard should be set to -30° (consult the 4-Stage Nitrous Retard Instructions for wiring). When used with a potentiometer, the timing will be retarded linearly from 0 to 30 degrees when a 0 to +5 volt signal is placed on a GP I/O input (channels 2-9). See **Figure 63** for wiring diagram.

**Speed Input:** The speed input is on pin 34 Orange/Black. The speed input allows the input of a frequency-based signal. Many late-model vehicles use electric speedometers that use either Hall effect or reductor triggering mechanisms. These are both compatible with the **TECgt200** speed input. Depending on the location of the speed input trigger wheel, you must configure the software to calibrate the speed input signal to the actual vehicle speed. See **Figure 65** for typical sensor wiring.

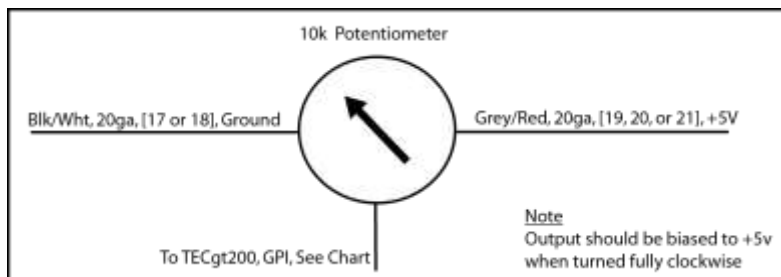
**Timed Advance:** When voltage (either 12v or 5v) is applied to the chosen GP I/O channel this function allows the user to add or subtract up to 30 degrees of timing for up to 2 secs. in .05 sec. increments. Timing will ramp up (advance) in the time specified (up to 2 seconds in .05 sec. increments) or down (retard) when the channel is switched on. Switching the channel off will ramp the timing back to the values in the Ignition Advance Table, the ramp back will happen in the specified time programmed by the user within the software.

**Datalog Enable:** Allows the use of on board data logging function. Options are RPM to begin data logging and Frequency (5, 10, 20 Hz) sampling rate. Wires the same as any input that is switched, such as the Valet Rev Limiter.

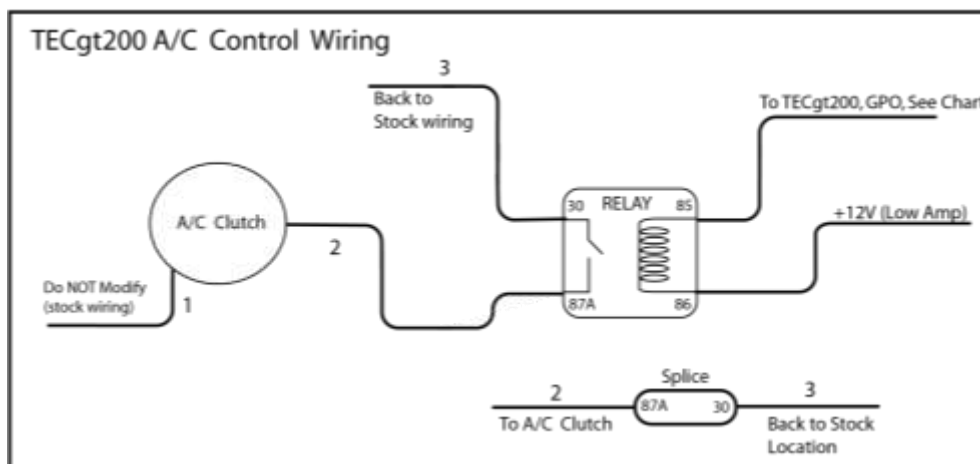
**Voltage Input:** No options, it just gives you a recordable voltage from 0 – 5 volts.

**Timed Ignition Cut:** option for shifting requires minimum RPM and minimum MAP value, amount of time for ignition cut in milliseconds, amount of time before ignition can be cut again. Finally, there is an option to pull to 12v (activate high) or pull to 0v (activate low). Additionally, the line must be released before the channel can be activated again.

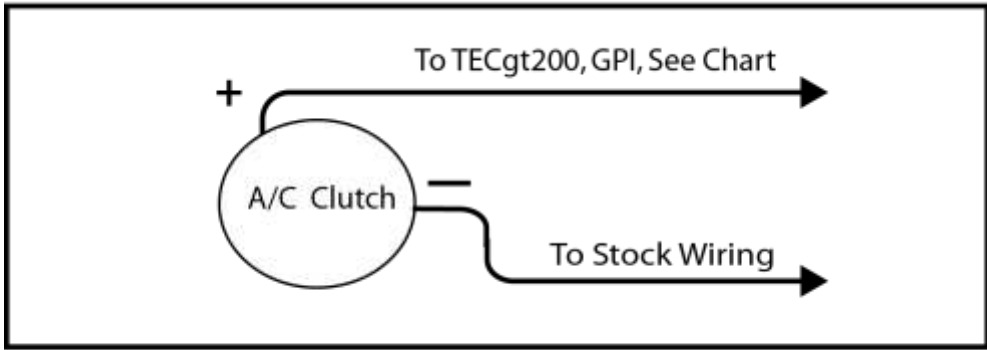
### 5.11.2 Wiring the GPI's



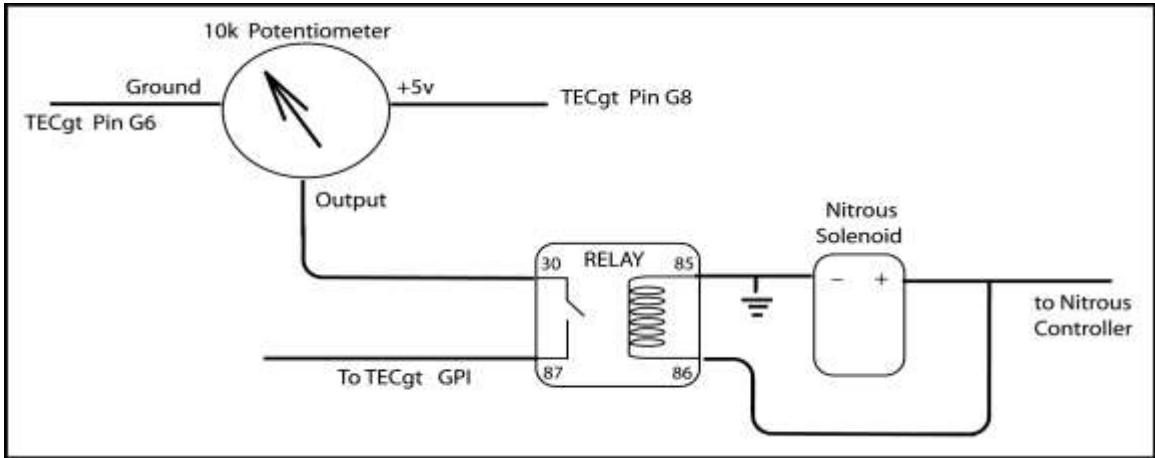
**Figure 60:** Potentiometer wiring for Fuel, Ignition and GP I/O Trim Inputs



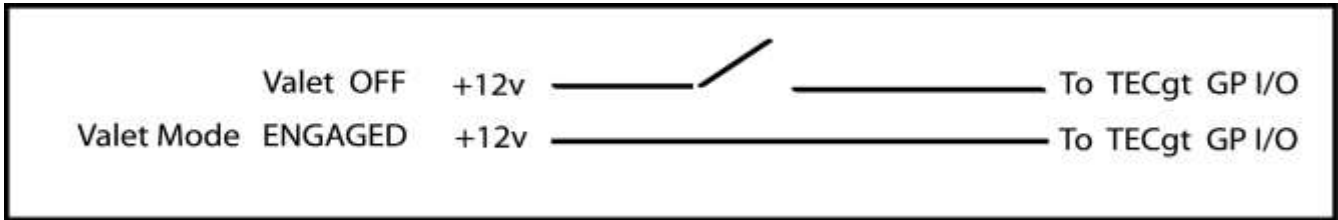
**Figure 61:** Air conditioner idle speed increase wiring.



**Figure 62:** Alternate air conditioner idle speed increase wiring. Note that the A/C clutch solenoid polarity **MUST** be known for this method.



**Figure 63:** Nitrous timing retard wiring.



**Figure 64:** Valet mode on/off wiring.

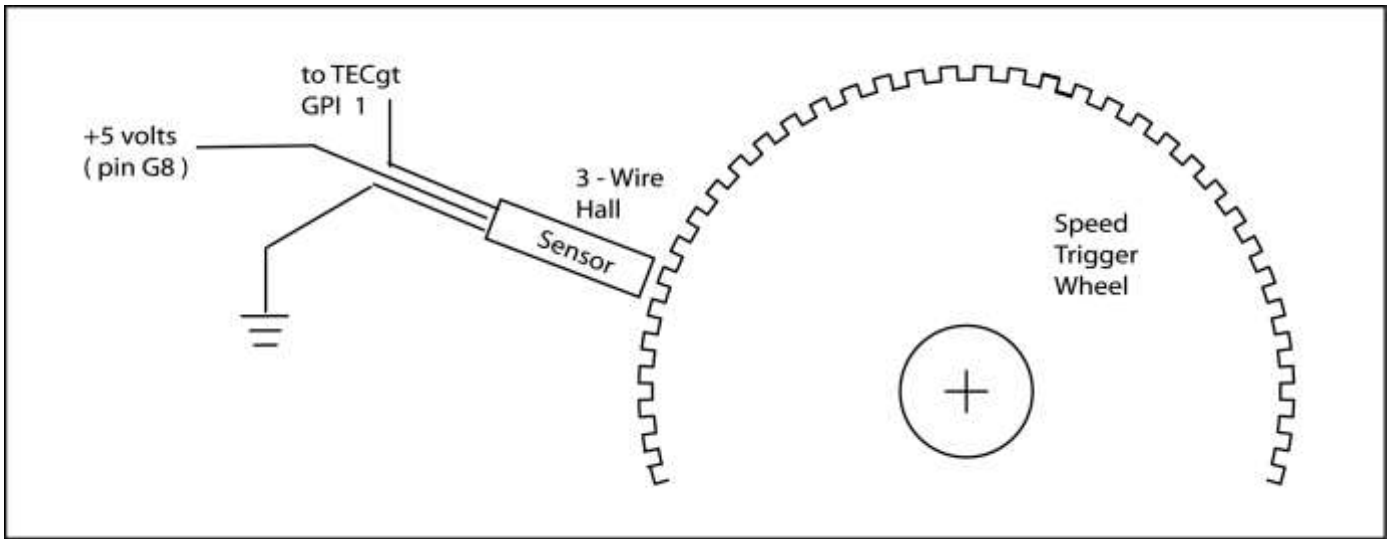


Figure 65: Typical speed sensor wiring

## 6 Wiring Outputs

### 6.1 Idle Air Control Motor

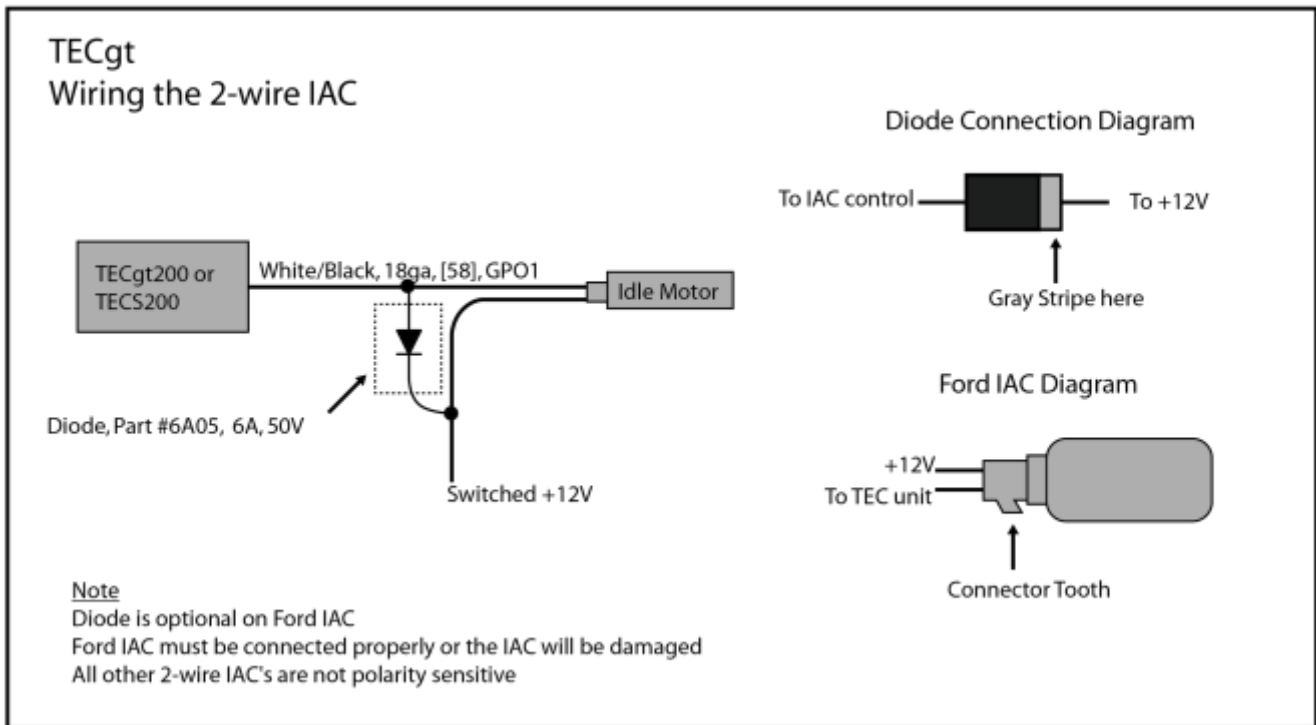


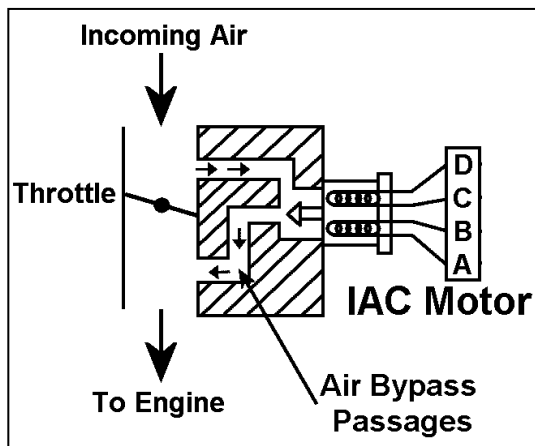
Figure 68 – Wiring the 2-wire IAC

The Idle Air Control (IAC) Motor is responsible for maintaining a smooth engine idle. Using the WinTec software, the IAC motor can be made to increase idle speeds during cold engine operation or air conditioner turn-on. The IAC motor control built into the **TECgt200** can be used with four-wire stepper motor-style IAC's. The stepper motor allows the pintle of the IAC motor to move in and out very quickly to allow varying amounts of air into the intake manifold. This way,



even with the throttle closed, the IAC motor can supply additional air to the engine. See **Figure 69** for an IAC motor plumbing diagram. See **Figure 68 or 71** for IAC wiring instructions. The **Tuning Guide section Idle Air Control Motor** covers the tuning of the IAC Parameters.

The idle speed control motor must be able to supply enough air to the engine so that it can have an effect on engine speed. Therefore, be sure to use at least a 1/4" hole for the air bypass passages.



**Figure 69:** IAC motor plumbing



**Figure 70:** IAC motor housing

For individual throttle applications, it will be necessary to use a balance tube to bring all the throttles to the IAC motor. This will allow each cylinder to be filled equally by the bypass air. A minimum of 1/2" inner diameter plumbing should be used for the balance tube to allow for adequate cylinder-to-cylinder consistency.

Electromotive offers a universal IAC Motor Housing for retrofitting an IAC motor onto an engine. The housing is designed around the Ford/Mazda bolt pattern, and as such, it fits many applications. It is also available in "universal" format with the addition of brass hose barsbs. (universal PN: 325-81112, Ford PN: 325-81114) This allows the installation of rubber hose onto the housing. One hose can then be run to the intake plenum with the other hose going to filtered air.

**With all Idle Air Control Motor setups, always make sure that the engine is receiving filtered air from the air bypass passages.**

**The IAC will not be activated unless the TPS voltage is BELOW the "TPS Closed Throttle Voltage" value. As an example, if the TPS voltage is 1.5 volts when the throttle is fully closed, the IAC motor will not be activated unless the "TPS Closed Throttle Voltage" setting is GREATER THAN 1.5 volts.**

### 6.1.1 Wiring a 2-wire IAC:

A 2-wire IAC should be wired as shown in Figure 68. The diode shown is required on all idle motors except some Ford motors. If the Ford IAC you are using had a diode across it in the original wiring harness, it is recommended that you use the original diode. If you never had an original harness, a diode should be used just to be safe. The Radioshack part will work in this case. Care must be taken to be certain that the polarity on the Ford motor is also correct. For those of you outside the U.S., Malpin carries diodes of similar spec to the Radioshack part.

### 6.1.2 Wiring a 3-wire IAC:

The 3-wire IAC requires the use of the 2-wire to 3-wire IAC adapter. The wiring is as follows: switched +12v source to the center lead of the IAC, pins C and D from the 3-wire IAC adapter will go to the outer leads of the IAC motor. If the IAC motor appears to be working backwards, reverse the wires to the two outer leads of the IAC motor. Switched +12v must also be connected to the IAC adapter pin B. The case of the adapter **MUST** be grounded. Pin A from the IAC adapter connects to the signal wire from the **TECgt200** unit. This setup does not require any diodes.

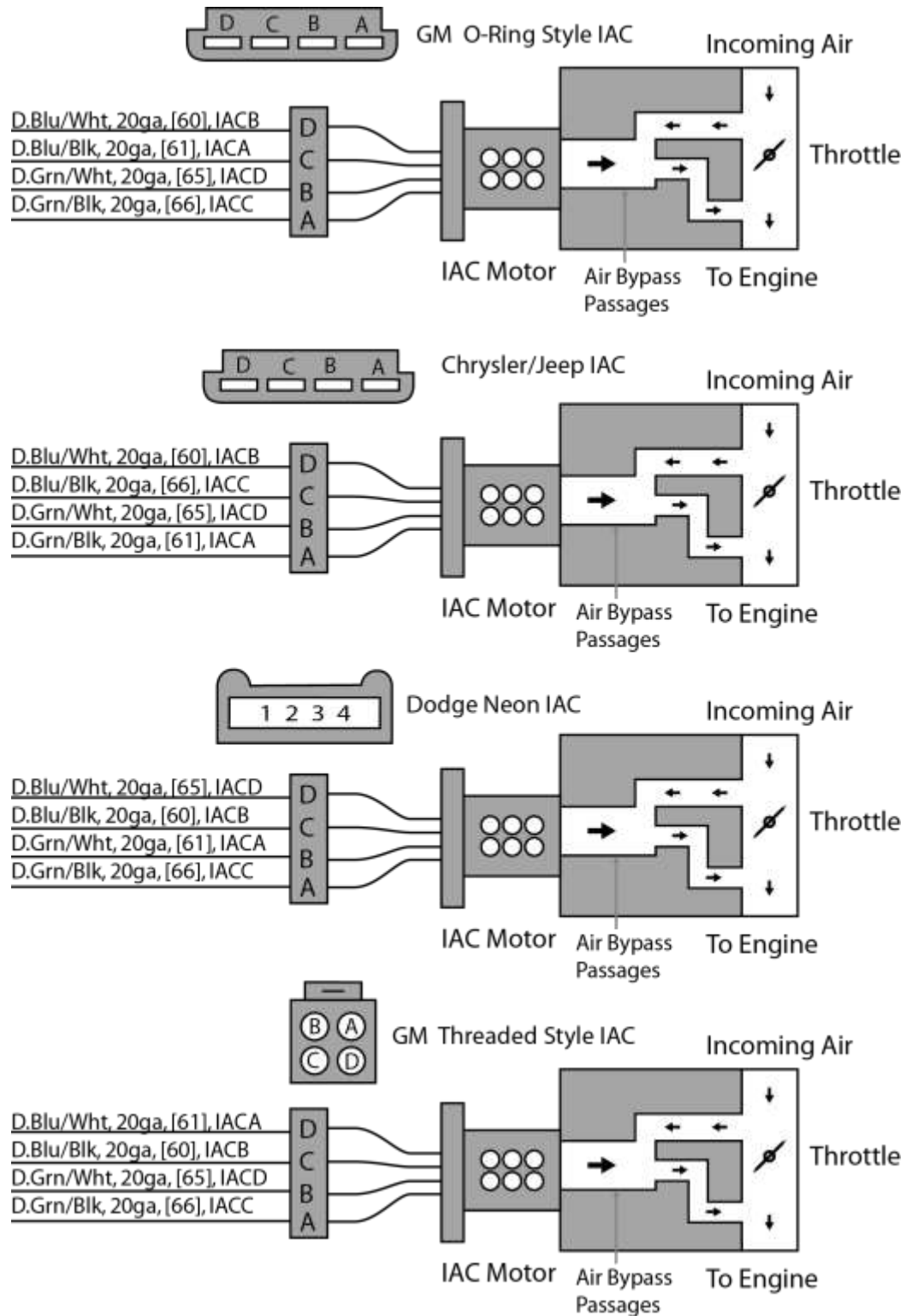
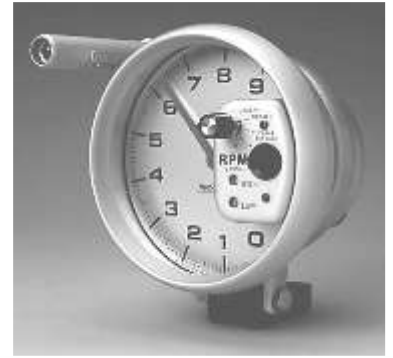


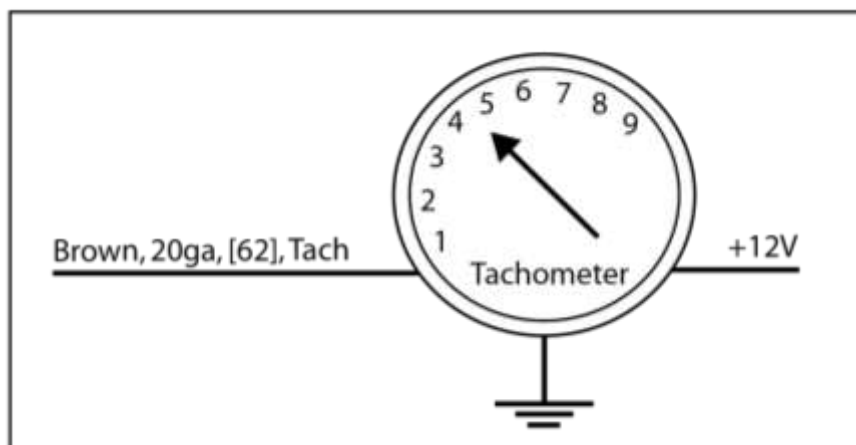
Fig 71: Common 4-wire idle air control motor wiring.

## 6.2 Tachometer Output

The tachometer output on the **TECgt200** is a +12 Volt square wave. Each time a coil fires, a “tach pulse” is generated. Therefore, the output from the tachometer signal is ground, then +12 Volts for 30 degrees of crankshaft rotation starting at each TDC/spark event. A 4-cylinder will output 2 tach pulses per revolution, a 6-cylinder will output 3 tach pulses per revolution, an 8-cylinder will output 4 tach pulses per revolution. For applications that have a tachometer configured for a different number of cylinders than the engine (i.e. a 6-cylinder car that was converted to an 8-cylinder), there is the option of changing the tach output type in the software.



This type of signal is compatible with most new-style tachometers. However, some older tachometers trigger off the high-voltage signal from the ignition coil (C-). These types of coils require the use of a tachometer amplifier, since they are designed to trigger off of a 120 Volt signal. Tachometer amplifiers (PN: 150-15210) are available from Electromotive to suit these applications.



**Figure 76:** Typical tachometer wiring.

## 6.3 Fuel Pump Relay Output

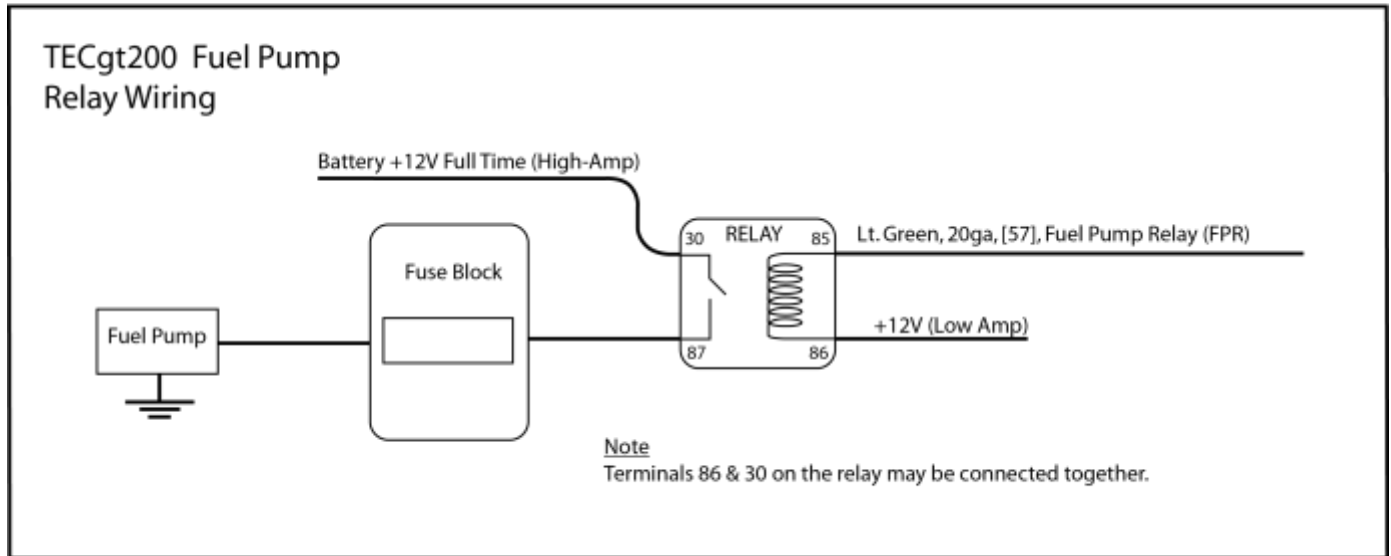
The fuel pump output is designed to provide activation of the fuel pump relay on a vehicle. It is NOT designed to power the fuel pump directly. See **Figure 77** for wiring instructions.

The software allows the user to define the amount of time that the fuel pump primes the system when the **TECgt200** is first turned on. This ensures adequate fuel rail pressure on start-up.

When the **TECgt200** is first turned on, the fuel pump will run for the amount of time defined in the software. If the engine is not cranked during or after this time, the fuel pump will turn off. Once the engine is cranked, the fuel pump will turn back on. Essentially, the fuel pump should always be running when the engine is rotating.

**CAUTION:**

Do NOT connect the fuel pump relay output directly to the fuel pump. This will cause an excessive amount of current to be drawn through the circuit, and may result in damage to your **TECgt200**.



**Figure 77:** Fuel pump relay wiring.

## 6.4 General Purpose Output (GPO) functions :

Some of the most versatile functions of the **TECgt200** computer are its GPO's. These outputs can control virtually any electronics device that is associated with engine operation. Take for example a simple electric radiator fan. Instead of retrofitting a thermo-switch mounted somewhere near the radiator's air stream to turn the fan on and off, you can simply use one channel of the **TECgt200's** GPO functions. To accomplish this task, you would first select the **Radiator Fan** option from the GPO menu. Then, you would input the temperature at which the fan should turn on, and the temperature at which it should turn off. The temperature readings are all obtained from the Coolant Temperature Sensor (CLT), so they are much more accurate and reliable than an external thermo-switch. The output of the GPO is a pull-to-ground, so you would run the appropriate GPO wire for the channel you defined as "Radiator Fan" to a standard 4-position automotive relay (pin 85 on the relay). The opposite side of the relay (pin 86) would be wired to +12 volts, and the relay would be switching the power (or the ground) to the fan with pins 30 and 87.

A few facts that must be remembered when using a channel for a GPO function :

- All the GPO's, regardless of their function, are pull-to-ground outputs when they are activated. That is, they create a connection to ground when turned on.

- A MAXIMUM of 1 amp may be drawn from each GPO circuit.
- It is HIGHLY recommended to use a relay on the output of the GPO channels, regardless of amperage draw. Only the FULL TABLE functions require NO RELAY or the use of a solid state relay. A standard relay will not switch on and off fast enough when using frequency based functions

### 6.4.1 Outputs

GPO Output	Pin Color	Function
GPO 1	58 White/Black	Pull Down to Gnd. 1 amp
GPO 3 / IACA	61 D.Blue/Black	Push-Pull 1 amp
GPO 4 / IACB	60 D.Blue/White	Push-Pull 1 amp
GPO 5 / IACC	66 D.Green/Black	Push-Pull 1 amp
GPO 6 / IACD	65 D.Green/White	Push-Pull 1 amp
GPO 7	54 White/Green	Pull Down to Gnd. 1 amp
GPO 8	64 White/Blue	Pull Down to Gnd. 1 amp
GPO 9	63 White/Purple	Pull Down to Gnd. 1 amp
GPO 2	55 White/Red	Pull Down to Gnd. 1 amp
C.E.	59 Pink	Check Engine Lamp Pull Down
Data Log Stat	56 White/Orange	Date Log Status Lamp Pull Down
FPR	57 Lt. Green	Fuel Pump Relay Pull Down

NOTE: When a 4 wire IAC motor is used, GPOs 3-6 are unavailable.

### 6.4.2 Available GPO Functions

**Radiator Fan:** See previous paragraph for functionality. See **Figure 80** for wiring diagram.

**Shift Light:** Turns on a shift light (or any other rpm-activated object) at a user-definable RPM. See **Figure 81** for wiring diagram.

**Torque Converter Control:** Use this GPO to control a lock-up torque converter. You are able to define the MAP and Speed points at which the torque converter clutch is activated. Since there is a multitude of different lock-up transmissions, an electrical schematic is not included for this feature. Consult the shop manual for your application to find the wire that engages the torque converter lock-up. Use a GPO channel to activate the proper wire. A relay should always be used for this function.

**Duty Cycle Table:** This GPO uses a 16 x 16 table of MAP reading vs. RPM to allow the input of a duty cycle at each MAP/RPM point. Numbers are interpolated between cells to create a smooth curve. The possibilities of this GPO are extensive. Typically, it is used to control an rpm/load-dependent solenoid such as a turbo waste gate. You can select table 1 or 2.

**A/C Control:** This feature turns the air conditioner clutch off when the engine is above specific RPM and MAP values. See **Figure 82** for wiring diagram.

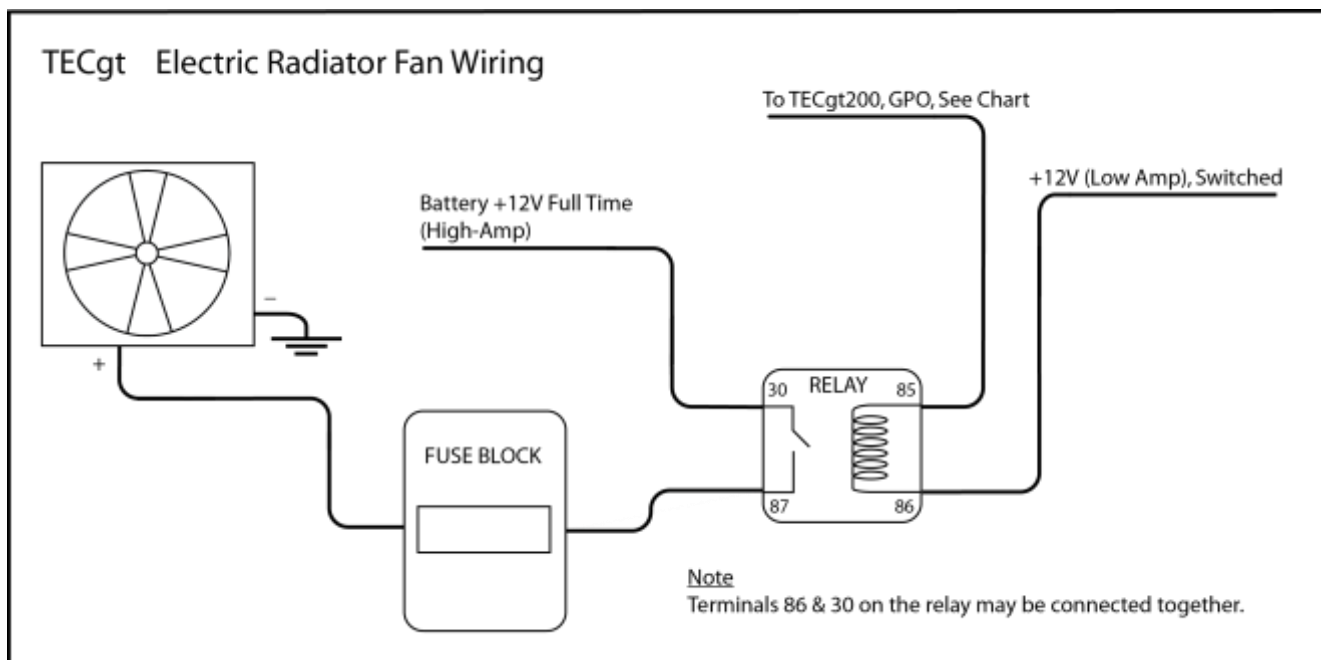
**Auxiliary Fuel Pump:** This GPO turns on an auxiliary fuel pump at a desired RPM and MAP value. See **Figure 83** for wiring diagram.

The **Intake Runner** and **Nitrous Controls** function in the same manner as the **Auxiliary Fuel Pump Control**. That is, they activate as a function of RPM and MAP value. Note that the Nitrous Control should not be used to turn on the nitrous directly. Instead, it should be thought of as a nitrous enable. This essentially replaces the wide-open-throttle switch. Use **Figure 83** for similar wiring.

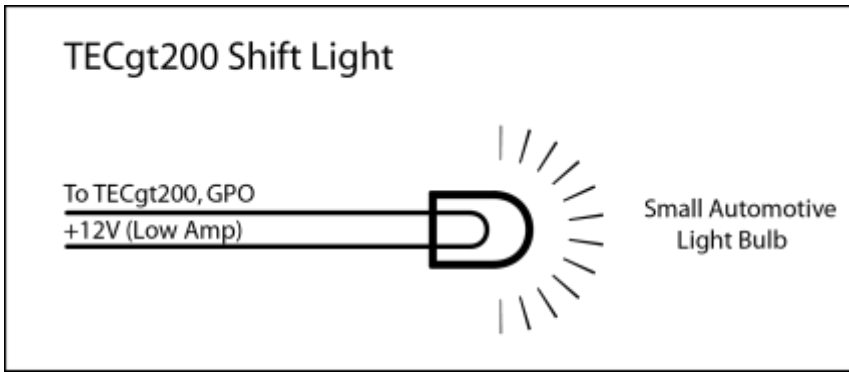
**Custom (and) / Custom (or):** Custom (and) uses both ranges RPM and MAP values. It requires RPM below which GPO comes on and MAP minimum turn on value. Custom (or) functions only inside either RPM or MAP values set OR both.

### 6.4.3 Wiring the GPO's:

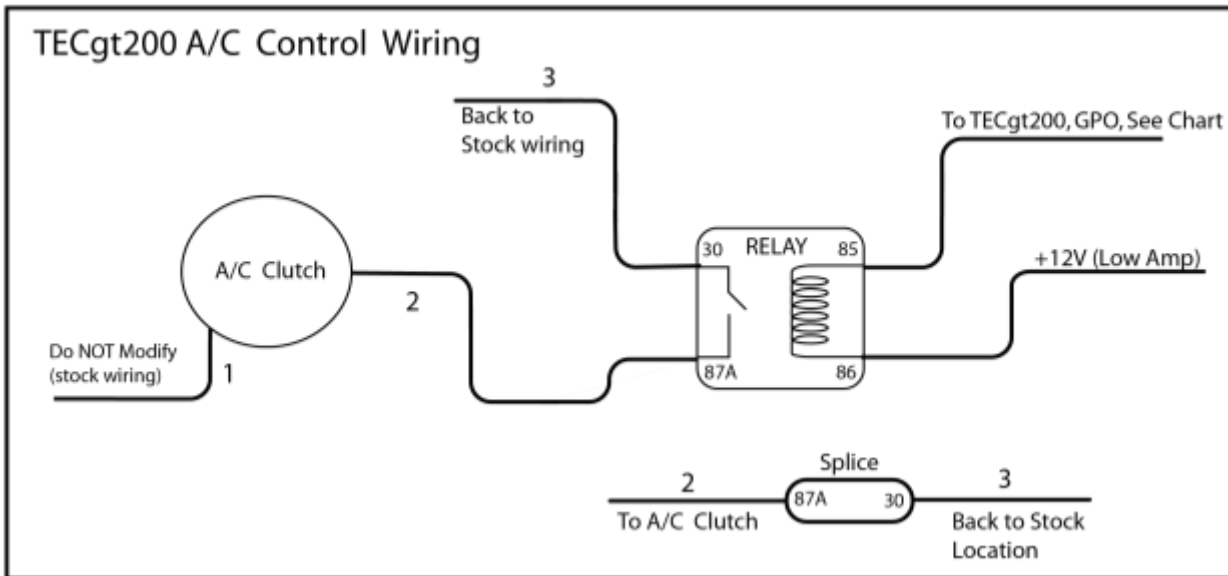
This section covers the wiring that is necessary to use the various GP I/O controls. With one exception (A/C turn-off), the relays depicted in the schematics are all simple automotive 4-position relays. The air conditioner turn-off request needs a 5-position relay. 4-position and 5-position relays are generally rated at 30 or 40 amps, which should be more than adequate for most applications. High quality relays and relay sockets are available from Electromotive under part numbers 340-91200 and 340-91201, respectively. Part number 340-91200 is a 5-position relay, so it can be used for all applications depicted below.



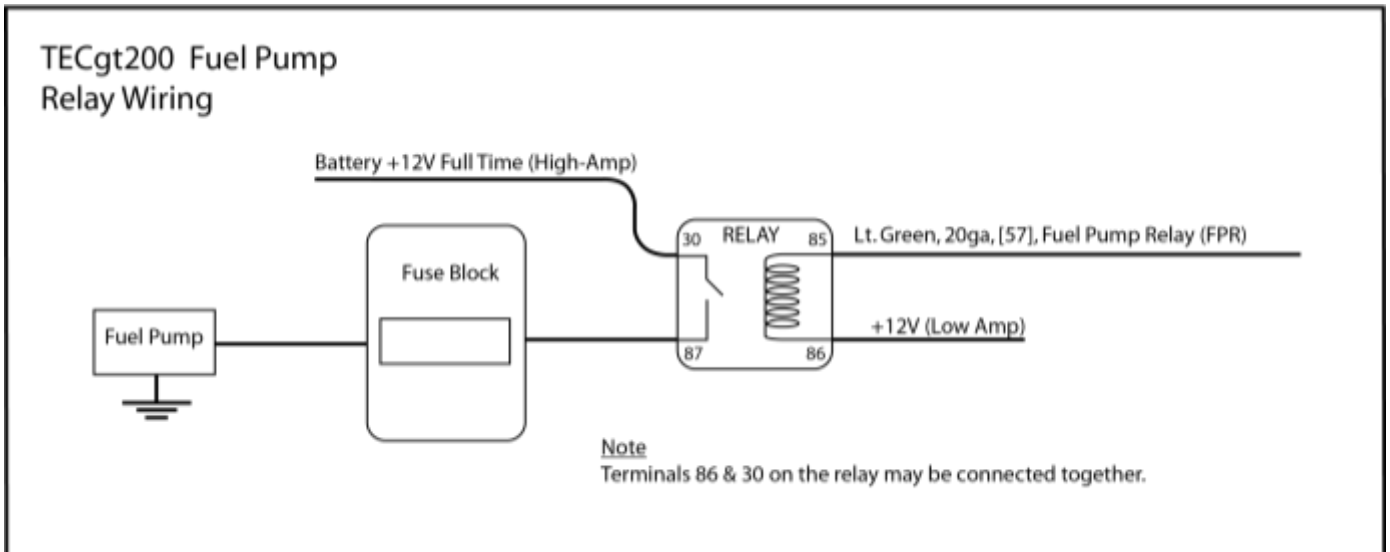
**Figure 80:** Electric radiator fan wiring.



**Figure 81:** Shift light wiring.



**Figure 82:** Air conditioner control wiring. Note that the relay simply splices into either of the two wires on the A/C clutch with terminals 30 and 87a. When activated, the A/C control will break the (normally-closed) connection between 30 and 87a by grounding pin 85.



**Figure 83:** Auxiliary fuel pump wiring.



## 7 Communications Ports on the TECgt200

The TECgt200 has 3 serial communications ports built into it. You must connect to one of them to program the TECgt200.

### 7.1.1 PC communications, USB port

The built in USB port allows you to directly connect the TECgt200 to your laptop computer without an adapter. Use the connector built into the wire harness to plug directly into your laptop. When plugging the USB jack into your computer, you should hear the “beep-beep” that tells you that Windows has found the USB equipped TECgt200 and that the driver is loading automatically from Windows. You may have to have your computer connected to the internet to complete this task. Use Electromotive’s Wintec4 to begin the calibration process. When opening Wintec4, make sure that Wintec4 discovers your USB connection and its on the correct port number.

Note on finding the USB port:

If Wintec4 cannot find the USB port it is because the PC has assigned the new USB connection to a number higher than 12. To correct this, go to your computer control panel and select hardware device manager. Then look at Ports, If the USB port number shows a number higher than 12, select that port and then select advanced. Change the port number to one that is less than 12. Close that and go to Wintec4 control options and change the communications to that new port number.

### 7.1.2 PC communications, RS232 Serial port

The TECgt200 also has the old style RS232 serial port that some PC computers still have. The TECgt200 functions will work identically for either USB or RS232. Do not use both ports at the same time. Make sure the Wintec4 software finds the right port number, usually 1 or 2.

### 7.1.3 CAN bus serial port

TECgt200 has a built in CAN bus port to transmit engine data to other computers on your car. Your supplier of the other computers should have already contacted Electromotive on the details of the data stream. Remember to turn the CAN bus data on in the calibration set up if you need it.

Serial Port	Pin Color	Function
RS 232	30 Brown in 7 conductor cable	Ground
RS 232	31 Orange in 7 conductor cable	RXD
RS 232	32 Blue in 7 conductor cable	TXD
USB	35 Black & Shield in 7 cond. cable	USB Gnd
USB	36 Red in 7 conductor cable	USB PC 5V
USB	37 White in 7 conductor	USB D-
USB	38 Green in 7 conductor	USB D+
CAN	51 Yellow/Pink	CAN High
CAN	52 Green/Pink	CAN Low

**Table. Summary of Serial Communications Ports**

# 8 Tuning Guide

## 8.1 Introduction

This section focuses on the tuning of a **TECgt200** equipped engine. The tuning procedures outlined here are based on an engine that has been wired correctly, has proper injector sizes, and has gone through the Tuning Wizard with the engine parameters to establish a base program. Failure to meet any of these criteria will make the tuning procedure difficult. Refer to section D.4 for terminology used in this section.

## 8.2 Adjusting the Timing Advance

Perhaps the most important step in tuning an engine is establishing the required ignition advance. An engine with too much timing will detonate, regardless of how much fuel is thrown at it. An engine with too little timing will perform poorly, and overheat the exhaust in short order. We are looking for the happy medium here. Keep in mind that the timing settings are solely dependent on the crank trigger installation angle. If the crank sensor is aligned with the 13<sup>th</sup> tooth of the trigger wheel when the engine is at TDC #1, the engine timing will be mechanically advanced by two teeth (12 degrees). When this occurs, the timing values in the Ignition Advance Table will be 12 degrees LESS THAN the actual engine timing. If the crank sensor is aligned with the 10<sup>th</sup> tooth at TDC#1, the timing will be mechanically retarded by one tooth (6 degrees). When this happens, the timing values in the Ignition Advance Table will be 6 degrees MORE than the actual engine timing. **Always confirm your timing values in the software with a timing light!** Remember that dial-type timing lights will not read correctly with the **TECgt200** due to the waste-spark. To avoid potential engine damage, it is best to check engine timing with a timing light when first starting the tuning process.

As a guideline, most piston engines, regardless of compression ratio, will require anywhere from 8-20 degrees of advance when the engine is idling. Rotary engines require little or no timing at idle (some even idle with negative advance!), so an ignition advance of zero may work best at low engine speeds. Less timing makes the combustion process occur later, and thus makes the exhaust temperatures higher. It also usually makes an engine idle somewhat rough. If your exhaust manifold is glowing red at idle, you know one thing: there is not enough timing. NO<sub>x</sub> emissions will typically be low with too little timing. More timing makes the combustion process occur sooner, and will decrease exhaust temperature. It also makes an engine idle smoother. NO<sub>x</sub> emissions will rise with too much timing.

With increasing RPM, the timing needs to be advanced for optimum power. This is a result of the available time for combustion decreasing with increasing RPM. The peak cylinder pressure needs to occur between 10 and 15 degrees after TDC compression for optimum power production, so the timing must be tuned to allow this to happen. As a rule of thumb, engines with slow-burning (large) combustion chambers, and/or low dynamic compression (low volumetric efficiency) typically need more timing advance, since the flame front moves slowly. Engines with fast-burning (usually small) combustion chambers and/or high dynamic compression ratios need less timing for optimum power, since the flame front moves faster.

Peak timing usually should occur by 3000 rpm on most engines. Load-dependent timing should always be used, especially on turbo/supercharged engines. With increasing load (i.e. full-throttle or full-boost), less timing is needed. With decreasing load (i.e. cruising), increased timing is needed.

Rotary engines (particularly the turbocharged rotaries) do not give the tuner a margin of error when it comes to ignition timing. They will detonate ONE TIME only, and will then be broken. The apex seals cannot stand up to the huge shockwave generated by detonation. Tune these engines extremely conservatively!! Start with the least amount of timing possible and the

most amount of fuel possible. A huge power-to-weight advantage is present on the rotary turbo engines, but it will only come to a tuner who is cautious and patient.

### **8.3 Establishing Proper Starting Enrichments**

When setting up the Starting Enrichments, it is generally best to first use the default settings from WinTec. If these settings cannot start your engine, there would only be two possible causes: either the enrichments are not adding enough fuel, or they are flooding the engine with too much fuel. Flooded engines are easy to spot, since there will be a strong fuel odor in the air around the engine. Alternatively, the spark plugs can be removed to check for flooding. Flooded spark plugs will be wet with fuel when they are removed. If an engine is not flooded but still will not start, it is most likely not getting enough fuel.

For engines that will not start when cold, look to SE0 (the Temperature-Based One Second Starting Enrichment). If the engine is flooding out during cold starting, decrease this number. If this number is already zeroed out, and the engine is flooding, look to SE1 (the Constant One Second Starting Enrichment). If SE1 is too high, the engine will flood out during cold AND hot cranking, since its value is added regardless of temperature. If both of these values are set very low, and the engine still floods during starting, look to PW0 (the Fixed One Second Starting Pulse Width). Most engines will not need PW0, so it is generally best to set this to zero. ASE-0 and ASE-1 can also contribute to a flooding problem. If these values are set too high, there may be too much fuel present at cranking.

An injector that is stuck open can sometimes cause a scenario that can be confused with engine flooding on start-up. An injector that is stuck open will spray fuel into its respective cylinder as long as there is fuel pressure. This will fill a cylinder with fuel in short order and effectively lock the engine. The starter motor won't be able to turn the engine over, since an engine cannot compress liquid fuel very easily. Placing a screwdriver on the side of the injector and listening for a clicking sound is a good way to pinpoint a stuck injector. If the injector is not clicking, it is not opening and closing.

For engines that are not getting enough fuel on start-up, the procedure for tuning the Starting Enrichments is basically the opposite of that outlined above. On cold engines that are not getting enough fuel, check the SE0 parameter. If this value is not high enough, a cold engine will not get enough fuel to start. Coinciding with this, an engine will also need SE1 to be properly established for proper starting. SE1 has an effect on both hot and cold engines, since it is not temperature-dependent. Some engines may need PW1 to provide an additional amount of fuel pulse width, particularly on cold starts (temperatures below CLT0). However, this value is typically not needed for multi-port injection applications.

An injector that is stuck in the closed position can cause a scenario that can sometimes be confused with a lack of fuel on start-up. The cylinder that is fed by the stuck injector will not be supplied with fuel, and if the engine starts and runs, it will not be running on that cylinder. Fuel pressure issues can also cause a lean condition on start-up. Make sure the fuel pressure is adequate during cranking.

Once an engine has been started, ASE-0 and ASE-1 are very useful to making an engine perform flawlessly in the first few seconds after starting. ASE-1 is a decaying fuel enrichment that is added for a period of twenty seconds after start-up. It is used to combat the "lean shift" of hot injectors. Injectors that have been overly heated as a result of heat soak can cause this lean shift. Depending on injector design, up to 75% enrichment may be needed in ASE-1 to combat this scenario. ASE-0 targets the cold starting issue of wetting the cylinder walls adequately for a period of twenty seconds. Since it is temperature-dependent, ASE-0 has no effect above 80C coolant temperature. Both ASE-0 and ASE-1 ramp down to zero after twenty seconds.

## 8.4 Getting the Engine to Idle

Hopefully by now your engine is up and running. Most likely, the idle mixture needs some attention, as does the throttle stop screw. **It is recommended to keep the IAC motor OFF during this preliminary part of the tuning process** (incorrect values in the IAC settings will cause an engine to surge at idle, making tuning difficult, at best). Simply unplugging the IAC motor will do (you don't have to turn the IAC feature off in the software). Make sure the IAC motor is fully extended so that no bypass air is entering the engine. If you are unable to keep the engine running without your foot on the gas pedal, turn the throttle stop screw a few turns to open the throttle. This should keep the engine running.

If the engine is running rough, it is a result of too much fuel. Black smoke will most likely be leaving the tail pipe. If this is the case, decrease the IOT number until the idle quality smoothes out. Check to make sure the engine is not running on the minimum turn-on time for the injectors. If it is, the injector size may be too large, or the fuel pressure may be too high. If the engine is misfiring, it is a result of too little fuel. Increase the IOT number until the engine stops misfiring.

Timing also plays a big role in idle quality. Most piston engines idle well with at least 10 degrees of advance at idle. Rotary engines require less timing at idle (try zero degrees). If an engine is not responding well to IOT adjustments, and adjusting the timing does not help either, make sure the coils are wired correctly. Also check that the spark plug wires are all connected to the *appropriate* cylinders. Check the wiring section if you are unsure on this one.

If the MAP sensor reading is fluctuating at idle, or its value is above 75kPa, it is recommended that the TPS/MAP Blend feature be turned on. The Tuning Wizard does this automatically when a "radical camshaft" or "Individual throttle-per-cylinder" is chosen for the setup. It will be necessary to adjust the Blend parameters as needed to achieve a smooth MAP signal. Adjusting the TPS Offset Voltage in the Blend parameters has the effect of adding or subtracting fuel. A higher offset voltage will move the MAP sensor reading UP in kPa, thereby making the engine run richer. Conversely, a lower TPS Offset Voltage will drive the MAP sensor reading DOWN, making the engine run leaner. Nearly all throttle-per-cylinder applications will require the use of TPS/MAP Blend. Similarly, most radically-cammed, low compression engines (like engines built for nitrous usage) will require Blend.

At this point, the VE Table should still be reading all zeroes in the Offset Mode (it should read all 100's in the Absolute Mode). Do not start adjusting the VE Table until the engine will start and idle on its own, and can be driven under low-load, low-rpm conditions.

## 8.5 Establishing Proper Acceleration Enrichments

It is recommended that the TPS (and possibly MAP) Acceleration Enrichments be defined before significant changes are done to the VE Table. However, the VE Table may need some attention when the TPS Acceleration enrichments will not make enough of a difference to the throttle response.

Since the MAP sensor reading is used for the primary load calculation on an engine, most applications will not require any MAP Acceleration Enrichments. It is therefore recommended that this feature be turned OFF. TPS changes, on the other hand, force an additional amount of fuel to be added to the cylinders. It is recommended that most applications turn the TPS Acceleration Enrichments ON.

Typically, the duration of the required fuel addition is around one second. For this reason, there is a set of enrichment parameters devoted solely to One Second Acceleration Enrichments. Additionally, lower coolant temperatures will often require more enrichment. Consequently, a temperature-based one-second enrichment is included.

What if an engine required an acceleration enrichment that was either longer or shorter than one second? This is where the Variable Time Acceleration Enrichments come into play. If an engine only needs 0.50 seconds of acceleration enrichment, simply set ACE-4 to be 0.50 seconds. The One Second Enrichments could then be turned off completely. The Variable Time Enrichments also have the ability to decay from the full enrichment value to zero enrichment as a function of the time defined in ACE-4.

To find the proper enrichment settings for an engine, it is best to start with proper TOG/UAP and IOT/POT numbers. Then, the VE Table should be tuned at as many points as possible under steady-state conditions. Once these conditions have been met, turn the TPS-Based Acceleration Enrichments ON. It is recommended that ACE-4 and ACE-5 be used for most engines once they are fully warmed-up. Start out with values of 50% for ACE-5 and 1 second for ACE-4. If the engine hesitates right after the throttle position changes, increase ACE-5. If it hesitates a short amount of time after the throttle position is changed, increase ACE-4. If the engine does not hesitate at all, decrease ACE-5 in 5% increments until the engine stumbles under acceleration, then increase ACE-5 by 5-10%.

ACE-8 and 9 generally are not necessary for an engine that has a properly tuned VE Table. However, if the engine is going lean during Acceleration Mode and all other acceleration enrichment, it may be a good idea to add a small amount to ACE-8 (start with 0.5ms). ACE-9 should normally not need to exceed 2 seconds on a tuned engine.

## 8.6 Adjusting the VE Table

Now you are ready to jump into that big table with all the numbers to fine-tune your engine. Be forewarned, however, that most engines (even throttle-per-cylinder setups) can run quite well with the VE Table zeroed out (as long as the engine is not overly radical). If you start making drastic adjustments to the VE Table, there is likely something amiss in your IOT and/or TOG settings. Radically cammed, high-rpm engines may require some substantial VE Table adjustments, though.

When making changes to the VE Table, it is a good idea to watch the injector pulsewidths on the bottom of the screen. If these values fall below about 1.4ms, your injectors are too big.

Begin the VE Table adjustment procedure by viewing the VE cells in which the engine is running (by using the cell highlight feature). This will show you where the engine is operating at a given instant, and will enable you to correct the appropriate cells. Try to operate the engine in a specific portion of the VE Table when tuning. This will allow you to fine-tune individual sections of the table to get an overall view of the corrections that need to be made.

For naturally aspirated (NA) engines, the TOG calculation that is made by the Tuning Wizard can be thought of as the necessary pulse width when the engine is at 100% volumetric efficiency. In reality, most NA engines will not operate at 100% volumetric efficiency unless they have a fairly radical camshaft and high compression.

Turbocharged and supercharged engines will operate at well over 100% volumetric efficiency. The calculated TOG number from the Tuning Wizard is scaled to make the specified boost peak the 100% load number. Therefore, boosted engines should enter the peak boost (plus 10kPa) that they intend to run as the highest point on the MAP scale in the VE Table. As an example, if an engine is to run up to 150kPa (absolute pressure), the peak MAP value in the VE Table should be 160 kPa.

The volumetric efficiency peak will coincide with the torque peak. When an engine is not at the torque peak, the volumetric efficiency is decreased. Typically, but not always, this goes hand-in-hand with a decreased fuel requirement when below the torque peak. Fuel requirements generally increase or stay roughly constant above the torque peak. Consequently, the VE Table should be adjusted to reflect the fuel requirements of an engine at all RPM's (and volumetric efficiencies).

If you are not able to get an engine to idle with the VE Table settings, it may be time to use TPS/MAP Blend. Blend is useful when the low-rpm pulsewidths are too high, and the VE Table adjustments are at their maximum negative allowance.

## 8.7 Using TPS/MAP Blend

It is necessary to first read the theory of operation for TPS/MAP Blend in the **Fuel Injection Section** of this manual. The relevant terminology for the Blend function is defined in that section.

When an engine needs blend, it is usually best to enter the same Blend Percentage Values around the idle RPM. That is, if an engine's idle speed is 800rpm, set all Blend Percentages to the same value from 1000rpm and below. This will keep the Blend routine from moving around with small idle RPM changes.

As a starting point, set the Blend Percentage Value at 60% for all RPMs around and below the idle speed. At around 200rpm above the idle speed, the Blend Percentage can be brought down smoothly to zero at around 2000-5000rpm. The more radical the engine, the higher the RPM point for zero Blend Percentage.

Optionally, the Blend Percentage can be set to a fixed level at all RPMs. This would effectively make the system use the TPS reading as part of the load calculation *all the time*. Taking this to the extreme, if the Blend Percentage was set to 100%, the load calculation would be *entirely TPS-based*. This is generally not a good tuning method, since throttle position is not a very ideal load indicator.

The Blend function should be thought of as two things: a MAP sensor filter and a pulse width modifier. When the MAP sensor reading is unsteady, but the engine is running at roughly the right pulse width, the TPS/MAP Blend can be used to smooth out the MAP sensor reading, and therefore smooth out the pulse width fluctuation. To accomplish this, enter a small amount of Blend Percentage (25-50%) near the idle point. Raise the TPS Offset Voltage to increase the pulse width to the desired level. Lower the TPS Offset Voltage if the engine is running too rich. The pulse width should stabilize once the proper settings are established.

## 8.8 Tuning for Cold Engines and Cold Weather

When an engine is cold, or when the intake air is cold, it will require additional fuel. To add this fuel, the **TECgt200** uses coolant temperature enrichments that are activated as functions of cranking, normal running, and accelerating. These enrichments are best tuned after an engine has been tuned when warm. Tuning the cold enrichments before an engine has been tuned when warmed-up can be misleading.

To begin with, the most important coolant temperature (CLT)-based enrichment would be the Warm-Up Enrichment. This enrichment adds a fixed percentage to the pulse width calculations as a function of engine temperature. If an engine is tuned at 90C coolant temperature, the Warm-Up Enrichment should be zeroed at 90C. At temperatures below 90C, the enrichment should ramp upward.

Starting a cold engine can also require an additional amount of fuel over and above that which is necessary on a warm engine. **SE-0** and **ASE-0** from the Starting Enrichment section can be increased to provide these enrichments as a function of engine temperature.

The Warm-Up Enrichment can be tuned by starting an engine when cold, and waiting for the 20 second enrichments to turn off (simply wait for 20 seconds after the engine has started). Add the required Warm-Up Enrichment at the current coolant temperature to achieve a smooth idle. Smooth out the curve from the current operating point to zero at 90C. For example, if the engine is at 30C and needs 40% enrichment, ramp the enrichment from 40% at 30C to 0% at

90C. For temperatures below 30C, back-track the slope of the enrichment curve upward (i.e. continue the line that was established between 30C and 90C). See the figure 99 for a typical Warm-Up Enrichment curve.

Cold weather operation lowers air intake temperature. Colder intake temperatures mean that the incoming air is denser than usual, and will require MORE FUEL to burn at the same air-fuel ratio. The density of air increases drastically with decreased temperature. The plot in **Figure 101** shows the Manifold Air Temperature Fuel Enrichment that would be required for various inlet temperatures. It is recommended that the MAT Fuel Enrichment be zeroed out at the normal operating intake temperature. This will eliminate one variable when tuning an engine. Also, it is highly recommended to ADD fuel with the MAT Fuel Enrichment when inlet temperatures rise to extreme levels. This occurs on most turbocharged engines when the turbo compressor is operating outside its efficiency range, or when an intercooler is not present.

Acceleration Enrichment values can also require additional fuel during the warm-up period. Parameter **ACE-2** adds fuel to the Fixed, One Second Acceleration Enrichment. ACE-2 will decay to zero enrichment once the coolant temperature has reached 80C.

## 8.9 Tuning the Idle Air Control Motor

Once an engine is running, and the parameters from have been tuned, the “**Tuning the Idle Air Control Motor Section**” can be turned on. The IAC motor has a few settings to establish the proper idle speed without oscillation. Also the IAC motor has the ability to provide increased air to the engine during cranking, without opening the throttle. **The IAC motor will only work if the TPS voltage is below that which is defined in the “TPS Parameters” section.** So if the TPS voltage is 1.5 volts at idle, the “TPS Voltage at Closed Throttle” will need to be set to 1.55 volts in the software in order for the IAC function to turn on.

To begin tuning the IAC motor parameters, turn the engine OFF. Define your desired idle speed as a function of coolant temperature. This is the target speed that the IAC motor will attempt to reach.

Start the engine, and watch the idle speed and coolant temperature. If the engine is idling higher than the desired idle speed setting, the throttle plate is opened too far or there is a vacuum leak on the engine. Try spraying carburetor cleaner around the intake manifold sealing surfaces to check for vacuum leaks, if the throttle plate is fully closed. If the engine is idling lower than the desired idle speed setting, then the IAC motor is not able to supply the engine with enough air on its own. When this occurs, open the throttle plate slightly.

Once the throttle plate is adjusted correctly, the IAC motor should be holding the engine’s idle RPM. However, the IAC motor may be causing an RPM oscillation. If this is the case, look to the rest of the IAC parameters.

Along with the IAC motor settings, the “Idle Advance” feature can increase the ignition advance when an engine falls below the desired idle speed, and decrease the ignition advance when the engine rises above the desired idle speed. This can help achieve the desired idle RPM, even on applications not using the IAC motor.

### 8.9.1 Configuring the New Electromotive Idle Speed Control

For information on wiring the 2-wire IAC, refer to the drawings at the end of this section.

- Go to the idle speed window and enter the following values:  
Error Sensitivity (+): 70 (when RPM is below target)

Error Sensitivity (-): 70 (when RPM is above target)  
Rate-of-Change Sensitivity (+): 1 (when RPM is increasing)  
Rate-of-Change Sensitivity (-): 220 (when RPM is decreasing)

- Click on the Min/Max DutyCycle button and enter values according to which idle motor you are using.  
Ford: Min = 1, Max = 255, Allow shutdown should be checked  
Honda: Min = 50, Max = 188, Allow shutdown should be checked  
Bosch (should be most German cars): Min = 100, Max = 255, Allow shutdown should be checked  
Mazda: Min = 60, Max = 155, Allow shutdown should not be checked  
Electromotive Stepper: Min = 50, Max = 185, Allow shutdown does not effect this motor
- Pick your idle targets as discussed in Section B.8
- Make sure to pick the control motor type (2- or 4-wire).
- If you are using a 3-wire motor, you must have a 3-wire converter box. Select the 2-wire setting and connect your motor using the 2-wire to 3-wire converter.
- Reset position sets the position that the idle motor will be in after the RPMs drop below the Decel limit. A good starting point for this value is 8.

### 8.9.2 Idle Speed primer

This idle is a bit complex and can be a bit tough to familiarize yourself without having seen such a system before. However, the process should not be terribly difficult to get through.

The Error Sensitivities define the sensitivity to the difference between the current RPM and the desired RPM. In order to prevent stalling, the rate at which the engine slows down must also be monitored so that the RPMs can be caught to prevent stalling. This is done with the Rate-of-Change Sensitivities. A large value should generally be used with falling RPM and a smaller value should be used with the rising gain. The Error Sensitivities and the Rate-Of-Change values are calculated separately and then added together. This allows the case where the RPM may be higher than the target RPM, but because it is falling rapidly, the idle motor will actually begin to open, to prevent idle droop or a stall. Below are some graphic examples of how these parts work.

### 8.9.3 Getting the IAC Started

Attempt to start the engine. If the engine starts hard, try reducing the maximum duty cycle until the startup revs are under control. Unfortunately, this trick does not work with the 4-wire IAC. If the engine starts too hard with the 4-wire, try increasing the Positive rate-of change to help arrest high startup revs.

After starting the engine the first time, chances are that it will not hold idle. In some cases, the idle will be stable, or nearly stable. But most of the time, the engine will oscillate and possibly die. Increase the minimum duty cycle until the engine runs without stalling. Once you have done this, you can adjust the minimum duty cycle back down until the desired idle speed is achieved. Generally you will want the engine to idle with an IAC reading of 1-2%. If you decreased the maximum duty cycle very much to stop hard starts, you may consider adjusting your throttle plate instead of increasing the minimum duty cycle.

Once the idle minimum and maximum is set, rev the engine to various RPMs to make sure that the engine returns smoothly to the correct idle speed. Adjust the Reset position until it does.



Adjust the falling sensitivity until the idle settles above the target and the arrow indicators for the IAC flicker back and forth. Reduce the falling rate sensitivity until the idle drops. Adjustments to this value should be made in increments of 1 or 2. Adjusting more than that can very quickly cause the RPMs to oscillate.

Once the idle is stable and revs return smoothly to the target idle speed, the car should then be drivable. Little if any adjustments should be required to finalize the idle settings.

### 8.9.4 Error Sensitivity

Error Sensitivity controls how rapidly the idle motor will move in reaction to the error of RPM at any given time. The picture below shows how the **TECgt200** unit finds error.

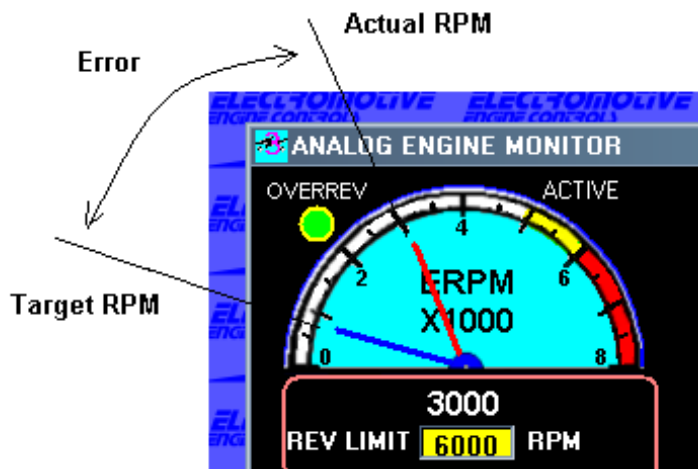


Figure 90

### 8.9.5 RPM Rate-of-Change Sensitivity

Rate-of-Change sensitivity controls how rapidly the idle motor moves in reaction to the RPM changing. For example, if the RPM is dropping slowly as in example A in Figure 2, the Rate-of-Change sensitivity will result in very little reaction. If the RPM is dropping rapidly as in example B in Figure 2, the reaction will be larger. The Rate-of-Change calculation will always work against the direction of motion. This is the adjustment that will prevent the engine from stalling when the throttle is closing. It can be thought of as an adjustable dashpot.

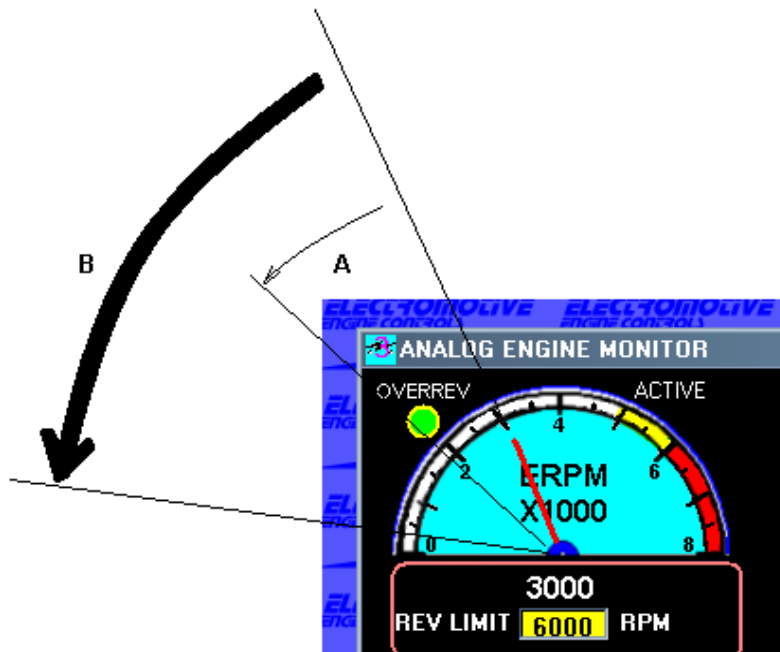


Figure 91

## 8.10 Tuning Tips:

In most cases, the default values given in the initial setup will be relatively close to the setting your car will need. The settings you will need depend heavily on the size of your engine and the size of the idle motor. For example, if you have a 302 V-8 and are using the Electromotive stepper idle motor, larger sensitivity values will usually be needed because the idle motor must make larger changes to get the engine to respond. In a case where the factory Idle motor is being used, the starting settings given above will likely work well because the idle motor is properly sized for the engine. Regardless of engine/idle motor combination, the default configuration should be close.

### 8.10.1 Other tips:

If your engine starts and maintains idle, but the idle drops too low when lifting off the gas and then rises slowly to the target RPM, a likely solution is to increase the Reset position. This will help to slow the rate that the RPM drops when lifting off the gas. You could also try a slight increase in falling rate sensitivity.

If the engine keeps shooting past the rpm target in both directions without stopping (RPM is oscillating), try reducing both proportional gains. These values should both generally be the same.

If the engine revs very high when starting (hard start), try decreasing the maximum duty cycle value. This will reduce the amount that the idle motor can open thus reducing how high the engine can rev on startup.

If when revving the engine, the engine rpm oscillates a little bit around the decel rpm while falling, reducing the reset value should help to prevent this. If the engine falls below the idle target and almost stalls, a larger reset value will help.

## 9 Fuel Injection

### 9.1 Fuel Injector Pulse Width Derivation

The fuel injectors are controlled by the **TECgt200** in several different modes. The most common mode would be phase-sequential injection. During this mode of operation, injectors are fired once per revolution (TDC compression & TDC exhaust). As the engine speed increases, the time between TDC events decreases. However, the fuel injector needs to fire for roughly the same amount of time each revolution, regardless of engine speed (assuming an engine with a fairly flat torque curve). As a result, the percentage of time that the injector is turned on increases. We refer to the percentage of time on vs. time available as the *Duty Cycle*. We refer to the time (in milliseconds) that the injector is turned on as the *pulse width*.

- **Duty Cycle** = Time On ÷ (Time On + Time Off) = Time On ÷ Time Available
- **Phase-Sequential:** Time Available = Time for 1 engine revolution
- **Full-Sequential:** Time Available = Time for 2 engine revolutions

#### 9.1.1 TOG, IOT, and the Raw Fuel Curve

The **TECgt200** software establishes a *raw fuel curve* for the engine with two numbers: Time on for one Gama **TOG** (a.k.a. : User Adjustable Pulse Width UAP) and Injector Offset Time **IOT** (a.k.a. : Injector Offset Time). The TOG sets the slope of the fuel curve (related to MAP load), while the IOT offsets the curve up or down. These two numbers work in much the same way as the main jet and metering rod on a carburetor. That is, the TOG has a large effect on the high-load injector pulsewidths, while the IOT has a large effect on the light-load injector pulsewidths. TOG dynamically manipulates the raw fuel curve as a function of load, while IOT adds or subtracts a fixed pulse width to the raw fuel curve for all load points. See **Figure 92** for graphical representations of the TOG and IOT correlation. The following equation is used to determine the injector pulse width as a function of MAP Voltage, TOG, and IOT:

$$\text{Pulse Width} = [(\text{MAP Voltage} \div 5) \times \text{TOG}] + \text{IOT}$$

#### 9.1.2 Load Percentage

In the above equation, the variable “MAP Voltage÷5” is the **load percentage** at which the MAP sensor is operating. Since all MAP sensors output a maximum of +5 Volts at full load, the **TECgt200** uses this number to determine the percentage of full load at which the engine is operating. For a MAP reading of 4.5 Volts, the load percentage would be  $4.5 \div 5 = 0.9$ , or 90%. Since the **TECgt200** does NOT know whether the MAP voltage is from a 1-, 2-, or 3-Bar MAP sensor (that is, it only knows the voltage), it is necessary to enter the MAP sensor that is being used into the software. See **Table 7** for a numerical breakdown of the MAP sensor voltage and corresponding load percentage.

**Table 7:** MAP sensor load percentage, voltage, and kPa relationship.

MAP volts	% Load	1 bar kPa	2 bar kPa	3 bar kPa
5	100	104.8	208	316
4	80	86	168	252
3	60	67	128	190
2	40	48	88	127
1	20	29	48	64
0	0	10.3	8	1.1

### 9.1.2.1.1 Linear Thermodynamics

There is no RPM-dependency for the raw fuel curve derivation. The governing principle behind this is that the pulse width requirements for an engine with a smooth (flat) torque curve will not have a very large RPM dependence. Rather, the pulse width requirement will be mainly load dependent with only a small RPM dependence due to volumetric efficiency variations (i.e. torque peaks at specific RPM points).

To summarize this principle, an engine at 100% load will require 100% of the pulse width value defined by TOG. An engine at 50% load would require 50% of the TOG, and an engine at 0% load would require 0% of the TOG (the MAP sensor determines the load percentage). Electromotive refers to this as “Linear Thermodynamics.” Keep in mind however, that the Linear Thermodynamic principle is a simplification that is useful for getting an engine up and running quickly. High-RPM engines that have a weak torque curve at low RPM’s will stray from the thermodynamically linear assumption. Turbocharged engines that do not start to create boost until high RPM’s will also stray from the thermodynamically linear assumption. However, these engines can still be tuned quite easily by choosing appropriate values for TOG and IOT, then manipulating the Volumetric Efficiency table and TPS/MAP Blend Parameters. Engines in which the MAP sensor is a good indicator of engine load will typically adhere quite strongly to Linear Thermodynamic principles. Indeed, most production engines (even modern DOHC engines) can be made to run acceptably well with no Volumetric Efficiency Table offsets to the raw fuel curve, even when outfitted with individual throttle-per-cylinder setups (using the TPS/MAP Blend Parameter)! However, it is recommended that the Volumetric Efficiency Table be manipulated once the engine is running acceptably well to attain optimum drivability and power.

### 9.1.3 Volumetric Efficiency Corrections

To provide both RPM and Load corrections for engines that stray from thermodynamic linearity, the **TECgt200** software has a Volumetric Efficiency (VE) table. This table allows corrections to the raw fuel curve at all rpm and load points. This is quite useful for high revving and turbocharged engines, since they often have very non-linear torque curves. Adding the VE correction to the pulse width calculation:

$$\text{Pulse Width} = [(\text{MAP Voltage} \div 5) \times \text{TOG} \times (\text{VE “Absolute” \%} \div 100)] + \text{IOT}$$

### 9.1.4 TPS/MAP Blend

Engines with high-overlap camshafts or throttle-per-cylinder setups (Hilborn-style) often experience erratic MAP sensor operation at low RPM’s; particularly around idle. The main problem is that these engines will either produce a non-consistent or weak MAP signal at low RPM’s. To compensate for this, the TPS/MAP Blend feature should be used. This feature allows the low, constant voltage of the throttle position sensor to be blended with the erratic, weak MAP signal at low RPM’s. In effect, it “tricks” the **TECgt200** into thinking that the engine is operating at a lower manifold pressure (higher vacuum) with a consistent MAP sensor voltage.

### 9.1.5 Alpha-N Fuel Calculation

When the Alpha-N calculation is selected, the TPS/MAP blend ratio is set to 100% everywhere. This also enables a barometric pressure correction table. The MAP pressure sensor input is converted to a barometric pressure sensor input. Make the appropriate adjustments in the barometric pressure correction table. Connect a barometric sensor to the MAP sensor input [44].

### 9.1.6 Other Corrections

The fuel pulse width is also affected by the enrichments imposed by the TPS acceleration (TPS), coolant temperature (CLT), air temperature (MAT), oxygen sensor correction (EGO), starting enrichments (SE) and battery voltage (BTO). With the exception of BTO, these enrichments all *add a percentage* to the “VE Absolute %.” Conversely, the BTO adds a *fixed amount* (not a percentage) of *injector pulse width* in response to battery voltage.

**Pulse Width After All Enrichments =**

$$\{(\text{MAP Voltage} \div 5) \times \text{TOG} \times (\text{VE Absolute \%} \div 100) \times \text{TPS\%} \times \text{CLT\%} \times \text{MAT\%} \times \text{EGO\%} \times \text{SE\%}\} + \text{IOT} + \text{BTO}$$

### 9.1.7 Time on for One Gama (TOG)

Users of Electromotive’s other TEC systems will remember the Time on for One Gama **TOG** as the User Adjustable Pulse Width (UAP). The **TOG and UAP are one and the same;** only the terminology has changed.

The TOG is analogous to the fuel flow on a carburetor when the metering rods are in the up position (full fuel flow). **This number is the injector pulse width (in milliseconds) when the TECgt200 sees +5 Volts on the MAP sensor**, since +5 Volts on the MAP sensor is the highest load reading that a given MAP sensor can make.

For phase sequential applications, the on-time occurs every revolution. For full-sequential setups, the on-time occurs every two revolutions, and as a result, the TOG will be double that of a phase-sequential setup. The number that is defined for the TOG can be no more than the Maximum Controllable Pulse Width given in the software.

#### 9.1.7.1.1 Computing the TOG...

The TOG should be established by the software tuning wizard. The value generated by the wizard is an approximation that is used to get an engine up and running. It is not necessarily the ideal number for a given engine. However, in order to firmly grasp the meaning of this number, use the equations below for once-per-revolution injection schemes (i.e. phase sequential) and once-per-engine cycle injection schemes (i.e. full sequential). Note that the result from these equations is in SECONDS, not milliseconds.

- **Theoretical TOG (once-per-rev injection) =**  
[Calculated Injector Size ÷ Actual Injector Size]  
× [(60 ÷ Max Engine RPM) – Injector Recovery Time]  
– IOT

➤ **Theoretical TOG (once-per-engine cycle injection) =**  
[Calculated Injector Size ÷ Actual Injector Size]  
× [(120 ÷ Max Engine RPM) – Injector Recovery Time]  
– IOT

Where:

- “Your Injector Size” = the injector size that is on your engine
- “Calculated Injector Size” = the theoretically ideal injector size for your engine
- “Max Engine RPM” = the peak engine speed
- “Injector Recovery Time” = the time required for an injector to cycle (use 0.0012 seconds if unknown)
- “IOT” = Injector Offset Time

These calculations work for most 1-Bar applications, since most 1-Bar setups will reach the full +5 Volt reading on the MAP sensor. For 2-Bar setups that are not reaching +5 Volts on the MAP sensor (i.e. engines that run less than 15psi of boost), a scaling factor must be applied to the Theoretical TOG. The same scaling factor is also necessary for 3-Bar setups that are running less than 30psi of boost and for 4-Bar setups that are running less than 45psi of boost. Use the same scaling factor on the TOG for both once-per-revolution and once-per-engine cycle injection schemes. See the following equation:

➤ **Scaled TOG** = Theoretical TOG ÷ (Maximum MAP Sensor Voltage ÷ 5)

To find the “Maximum MAP Sensor Voltage” for your application, refer to **Table 8**. Match the peak manifold pressure that the engine will run with the corresponding MAP voltage. When the “Maximum MAP Sensor Voltage” is divided by 5, we refer to this as the *Load Percentage* (this is the number in the first column of **Table 8**).

**Table 8:** MAP sensor voltage & kPa relationship.

Load Percentage	MAP Voltage	1-Bar kPa	2-Bar kPa	3-Bar kPa
0%	0.00	10	8.8	3.6
5	0.25	15	18	17
10	0.50	20	28	33
15	0.75	24	38	48
20	1.00	29	48	64
25	1.25	34	58	80
30	1.50	39	68	96
35	1.75	43	78	111
40	2.00	48	88	127
45	2.25	53	98	143
50	2.50	58	108	159
55	2.75	62	118	174
60	3.00	67	128	190
65	3.25	72	138	206
70	3.50	77	148	222
75	3.75	81	158	237
80	4.00	86	168	253
85	4.25	91	178	269
90	4.50	96	188	285
95	4.75	100	198	300
100	5.00	105	208	315

**Sample TOG Calculation**

Engine: 30 lb/hr injectors. Peak RPM = 6000. Injector Recovery Time = 0.0012sec.  
 MAP Sensor: 2-Bar. Peak Boost Pressure: 168kPa (about 10psi).  
 Calculated Injector Size = 24 lb/hr. IOT = 0.

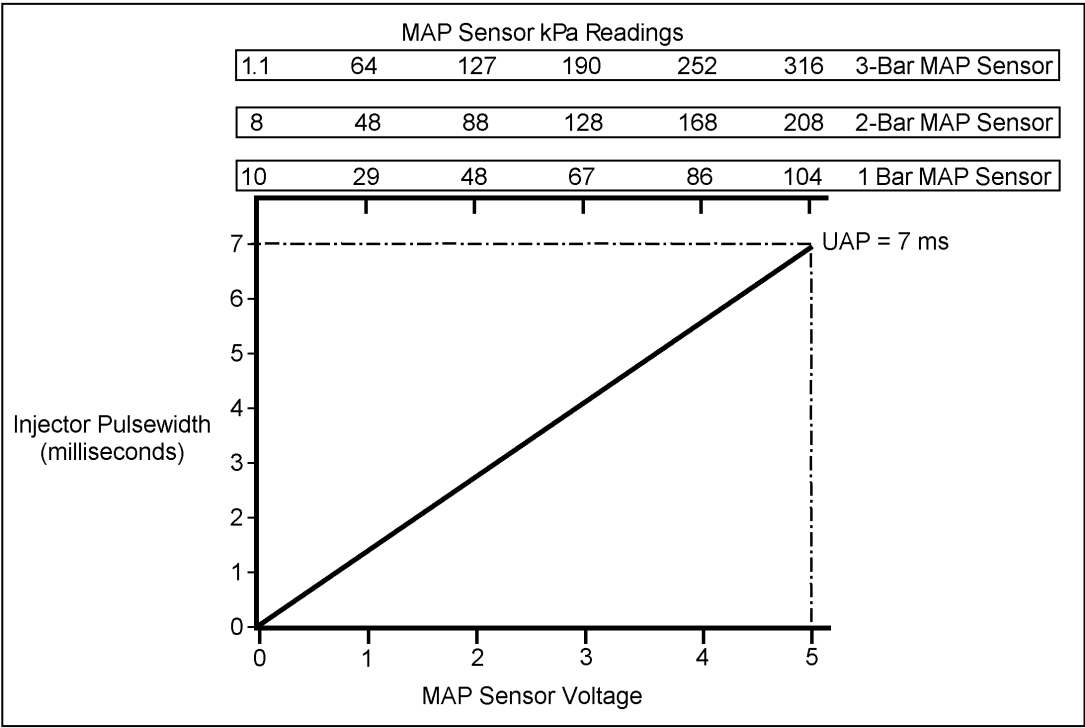
- Theoretical TOG** =  $\{24 \div 30\} \times \{(60 \div 6000) - 0.0012\} - 0$   
 $= 0.80 \times .0088$   
 $= 0.00704$  seconds = 7.04 milliseconds

**Theoretical TOG = 7.04ms**

- Scaled TOG** =  $7.04 \div (4 \div 5)$

**Scaled TOG = 8.80ms**

The **TECgt200** generates a straight line for the pulse width curve from the TOG value at **+5 Volts** on the MAP sensor to **zero pulse width at 0 Volts** on the MAP sensor. See **Figure 92** for a graphical representation of this.



**Figure 92:** Effect of TOG on injector pulse width. Note: TOG = 7ms, IOT = 0ms.

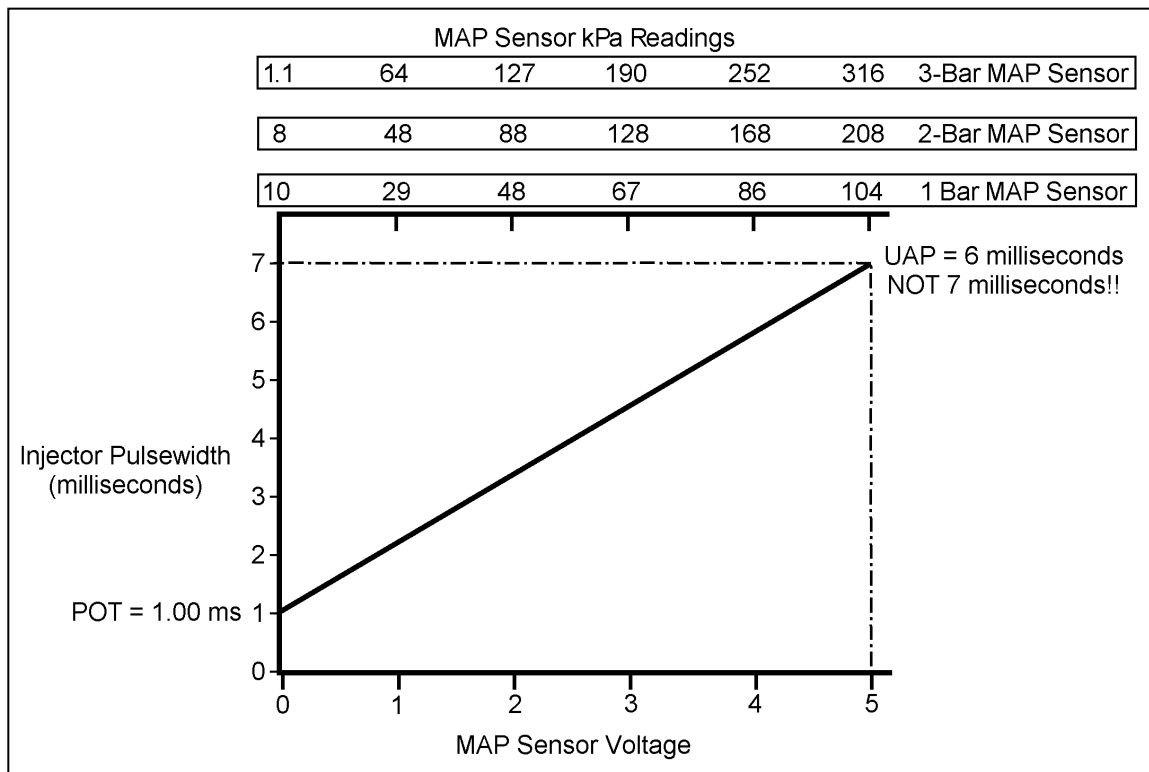


### 9.1.8 Injector Offset Time (IOT)

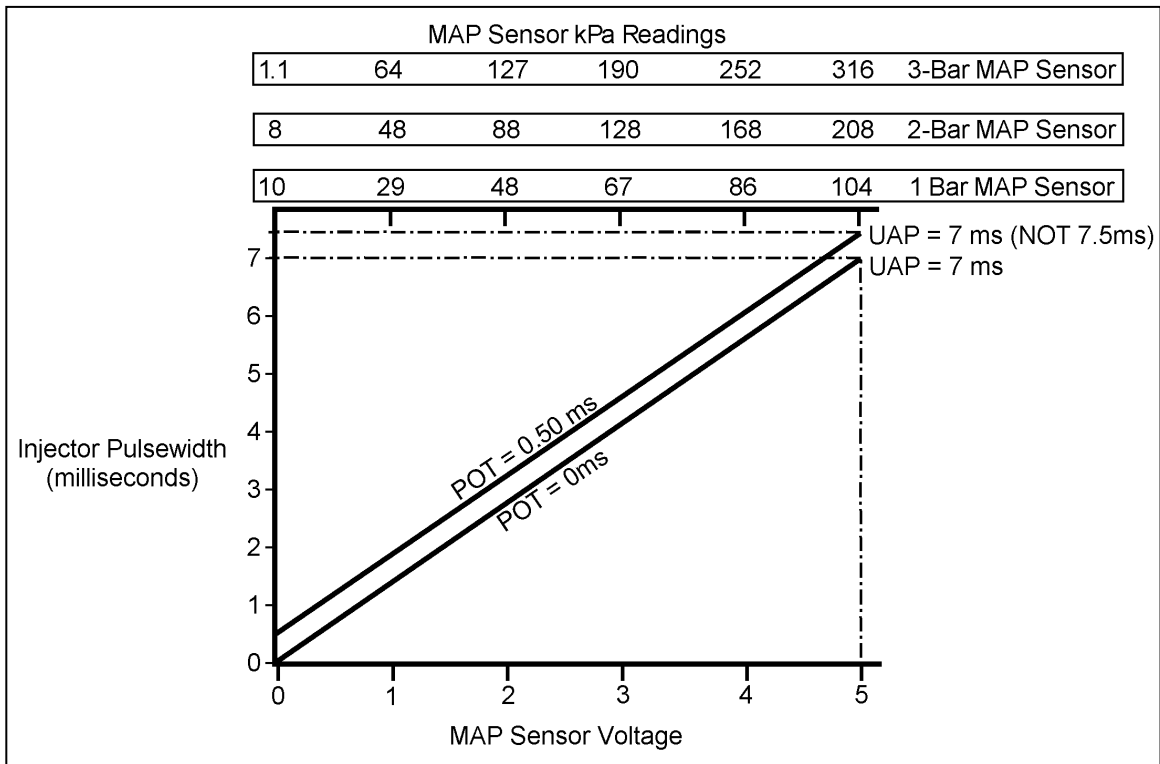
Users of Electromotive's other TEC systems will remember the Injector Offset Time **IOT** as the Pulse Width Offset Time (POT). The **IOT and POT are one and the same**; only the terminology has changed.

The IOT is analogous to the fuel flow through a carburetor when the metering rods are in the down position (minimum fuel flow). This number adds or subtracts fuel to the entire fuel curve. As such, IOT has its main effect on the low-load part of the fuel curve, since it provides a **large percentage of change on small pulse width values** (low load conditions), but a **small percentage of change on high pulse width values** (high load conditions).

Due to the fact that IOT is added or subtracted to the fuel curve at all points, the TOG must be adjusted in order for the injectors to remain at the same on-time at full load. That is, if an engine performed well under high load with a TOG of 7 milliseconds and a IOT of 0 milliseconds, it would be necessary to decrease the TOG by 1ms if the IOT was increased by 1ms in order for the full load tuning to remain the same. See **Figure 93** for a graphical explanation of this. Also, if it is desired to increase or decrease the raw fuel curve by a set amount of time, the IOT alone can be changed, as in **Figure 94**.



**Figure 93:** Effect of TOG and IOT on injector pulsewidth. Note: TOG=6ms, IOT=1ms.



**Figure 94:** Effect of TOG and IOT on injector pulse width. Note: TOG = constant, IOT changed from 0ms to 0.5ms.

**Some points to remember:**

- Changing IOT by itself results in a fixed increase or decrease of the pulse width number across the entire fuel curve.
- Changing TOG by itself results in adding or subtracting a percentage to the entire fuel curve.
- Changing TOG and IOT together affects the slope of the fuel curve.
- Select TOG and IOT such that the Volumetric Efficiency table corrections are at a minimum. (See next section for more details on this.)

### 9.1.9 Volumetric Efficiency Table Corrections

To compensate for engines that stray from thermodynamic linearity, the Volumetric Efficiency (VE) table comes into play. The VE table can be set to anywhere from 8 x 8 to 16 x 16 data points. The X-axis is the RPM and the Y-axis is the MAP reading. When the tuning program is first being established, the numbers in the VE table will be all zeros when the “Offset” view mode is selected (the numbers will be all 100’s when the “Absolute” view mode is selected). This refers to the fact that there is not yet any change in place from the raw fuel curve. Once a number is entered into the table, the raw fuel curve is modified at that particular point. Between cells in the VE table, a 256-point interpolation is occurring to smooth out the fuel curve. Otherwise, the fuel curve would “step” from cell-to-cell (and wouldn’t be much of a curve!).

The VE table allows the user to select between “Offset,” “Absolute,” “Pulse Width,” and “Duty Cycle” for the display mode. The “Offset” view mode will display zeros when there is no change to the raw fuel curve at a particular point. The Offset Number can be set to a negative or a positive number. When a negative number is entered, the fuel curve is leaner than the raw fuel curve at a given point. When the number is positive, it is richer than the raw fuel curve at that point. The “Absolute” view mode will display 100% when the fuel curve is unmodified. A number less than 100% will lean out the fuel curve, while a number greater than 100% will richen up the fuel curve. The “Pulse width” view mode shows the injector pulse width values that the **TECgt200** will use throughout the operating range. The numbers in the “Duty Cycle” view mode should not exceed the maximum value for an RPM when taking the injector recovery time into consideration. See the section on fuel injector selection for more details on this topic.

Since the Raw Fuel Curve defined by TOG and IOT is a two-dimensional graph (i.e. Load vs. Pulse width) and the VE table is a three-dimensional graph (i.e. Load vs. RPM vs. Pulse width), it is easy to visualize VE table changes at specific RPM points. As an example, if TOG was chosen to be 7ms, IOT was 0ms, and the engine ran well at peak torque and below, but was overly rich when above the torque peak, the raw fuel curve might be modified as in **Figure 95**. The modified fuel curve could be obtained easily by entering –30% into the VE “Offset” at all RPM/Load points above the torque peak. This type of modification results in a straight-line modification to the raw fuel curve.

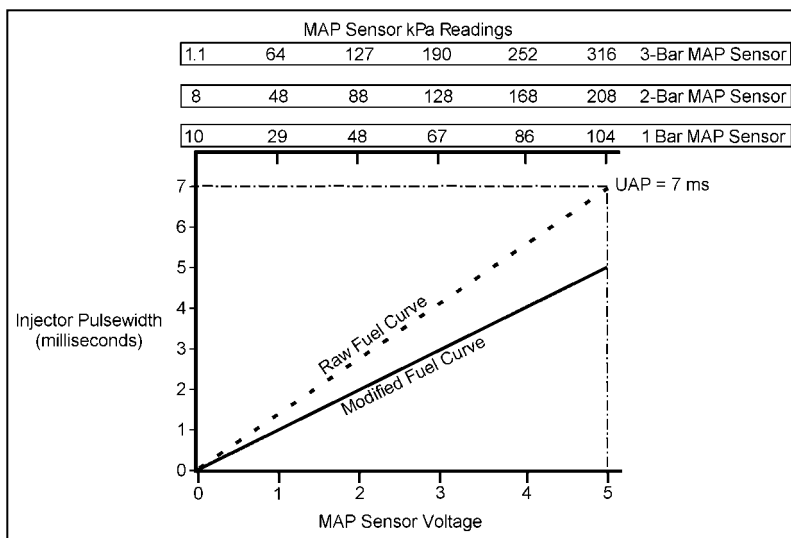
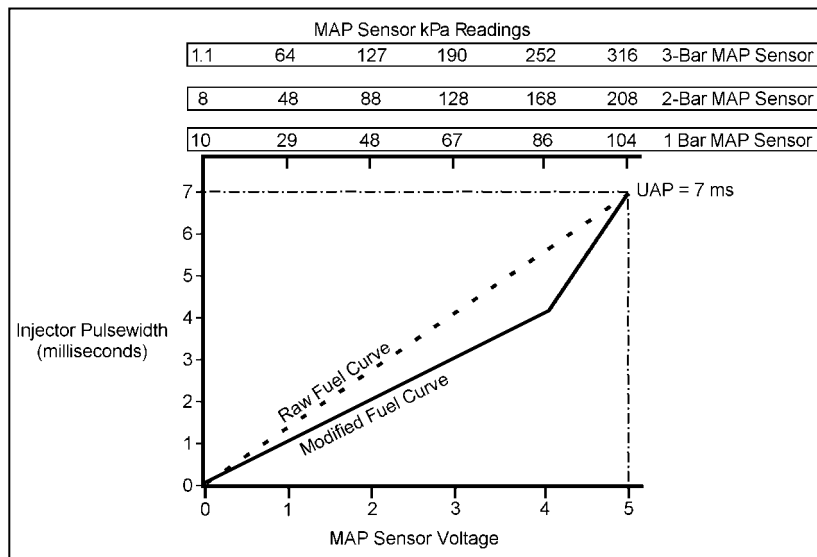


Figure 95

What if the same engine needs less fuel at around 80-90kPa for a particular RPM point (assuming a 1-Bar sensor)? The modification to the Raw Fuel Curve at the problem RPM may look something like **Figure 95**.



**Figure 96**

### 9.1.10 TPS/MAP Blend Corrections

The TPS/MAP Blend parameter is very useful on engines that have weak or erratic MAP sensor signals at idle and low RPM's. If your engine meets any of the following criteria, it is suggested that you consider using the TPS/MAP Blend function:

- Radical Camshaft (Long Duration)
- Individual Throttle-per-Cylinder (Hilborn- or TWM-style)
- Oversized Single Throttle
- High RPM Torque Peak (above 6000rpm)

These engines typically suffer from unstable MAP sensor readings at light load and low RPM operation. When this occurs, the MAP sensor reading is not very representative of an engine's fuel requirements. However, at light load (especially idle), the throttle position is fairly constant, and nearly closed. Thus, the TPS reading is both stable and has a low voltage output (typically less than 2 Volts) during these conditions.

When the **TECgt200** software is set up to use the TPS/Blend function, it takes the reading from the TPS and the MAP and combines them into one number. This number is then used as the MAP sensor reading. Consequently, when TPS/MAP Blend is being used, the displayed MAP sensor value when the engine is running will not be the output of the MAP sensor; it will be the **Modified MAP Value** from the TPS/MAP Blend.

A simple calculation is made to determine the modified MAP sensor value when using TPS/MAP Blend. The calculation uses the following inputs:

- Blend Percentage
- TPS Voltage
- TPS Offset Voltage
- MAP Sensor Voltage

These values are fairly easy to understand. The **Blend Percentage** refers to the biasing between the TPS and MAP sensor readings. If the Blend Percentage were set to 100%, only the TPS would be used for the Modified MAP Value. If the Blend Percentage were set to 50%, the Modified MAP Value would take half of its reading from the MAP sensor and half from the TPS. If the TPS read 1 Volt and the MAP sensor read 3 Volts, the modified MAP Value would be 2 Volts for this setup.

The Blend Percentage can be changed as a function of RPM. Typically, the Blend Percentage should be highest at low RPM's and lowest (usually zero) at higher RPM's. Typical 4-, 6-, and 8-cylinder street-based engines with individual throttles respond well when the TPS voltage is tapered to zero by 4000rpm. Around the idle speed (0-2000RPM), the Blend Percentage is typically kept constant somewhere between 45% and 75%. See **Figure 97** for a typical Blend Percentage curve.

The **TPS Voltage** is simply the current Throttle Position Sensor voltage reading. This can be observed from the engine monitor screen when the engine is running. Similarly, the **MAP Sensor Voltage** is the current MAP sensor reading that is observed with the engine running. This is the unmodified MAP sensor voltage.

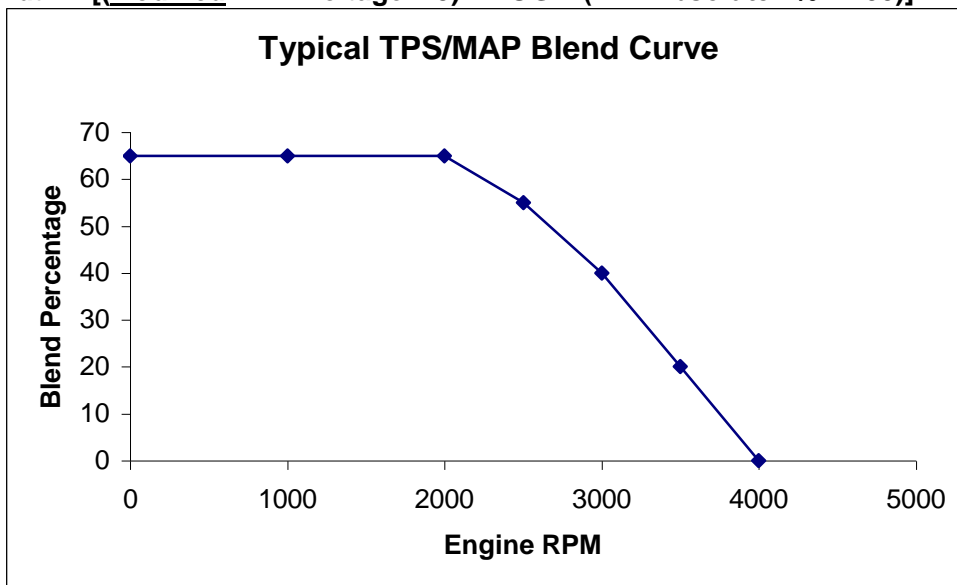
The **TPS Offset** is a number that is added to the TPS reading in the Modified MAP Value calculation. This number causes the actual TPS voltage to be increased slightly when it goes into the Blend routine. This is useful for placing the Modified MAP Value at the desired point. Generally, this parameter is used when the TPS output is not at the desired point. In practice, if an engine needs more fuel, the TPS Offset should be increased. If it needs less fuel the TPS Offset should be decreased. TPS Offset is not used for anything other than the TPS/Blend calculation (i.e. it will not be displayed as the TPS voltage on the monitor screen).

The four variables all come together in the following equation:

$$\text{Modified MAP Value} = [\text{Blend Percentage} \times (\text{TPS Voltage} + \text{TPS Offset Voltage})] + [(100 - \text{Blend Percentage}) \times \text{MAP Voltage}]$$

Keep in mind that the Modified MAP Value is used in place of the actual MAP sensor reading when TPS/MAP Blend is being used. As a result, the pulse width equation from before now becomes:

$$\text{Pulse Width} = [(\text{Modified MAP Voltage} \div 5) \times \text{TOG} \times (\text{VE "Absolute" \%} \div 100)] + \text{IOT}$$



**Figure 97:** A typical TPS/MAP Blend curve.

Take some time to learn how to use the TPS/MAP blend function. Getting a radically-cammed engine to idle nicely is very easy once you have mastered this feature.

### 9.1.11 Oxygen Sensor Corrections

The Exhaust Gas Oxygen (EGO) Sensor can provide for fuel injector pulse width modifications. In the software, the Air-Fuel Ratio Table defines the desired air-fuel ratio at the various operating points of the engine. When the EGO is turned on (in closed loop operation), the **TECgt200** will try to correct the injector pulse width to make the EGO reading the same as the numbers in the Air-Fuel Ratio Table. This is accomplished by sampling the reading from the EGO sensor, and adjusting the injector pulse width accordingly.

**An EGO reading that is numerically lower than the table value indicates a richer-than-desired air-fuel ratio.** When this occurs, the **TECgt200** will begin to shorten the injector pulse width. It does this by decreasing the “VE Absolute” percentage.

**An EGO reading that is numerically higher than the table value indicates a leaner-than-desired air-fuel ratio.** When this occurs, the **TECgt200** will begin to increase the injector pulse width. It does this by increasing the “VE Absolute” percentage.

**When discussing the air-fuel ratio of an engine, these terms are often used:**

- **Air-Fuel Ratio (AFR):** The ratio of incoming air mass to incoming fuel mass. A rich mixture would have a comparatively small ratio between the air and fuel (like 12:1), while a lean mixture would have a comparatively larger ratio between the air and fuel (like 16:1). Oxygen sensors measure the leftover oxygen content in the exhaust to try to determine this ratio.
- **Stoichiometric:** A chemically balanced air-fuel ratio that will result in (theoretically) zero excess fuel or excess air in the exhaust. For gasoline, this number is 14.64 parts air to 1 part fuel by mass. Thus, for gasoline, the stoichiometric air-fuel ratio is 14.64:1. Different fuels have radically different stoichiometric ratios.
- **Lambda:** The ratio of actual air-fuel ratio to stoichiometric air-fuel ratio. For a gasoline engine running at 14.64:1, lambda is  $14.64 \div 14.64 = 1$ . For an engine running at 12.5:1, lambda is  $12.5 \div 14.64 = 0.85$ . Thus, lambda normalizes the stoichiometric air-fuel ratio for comparison of different fuels.
- **Rich Mixture:** Excess fuel in the combustion process.
- **Lean Mixture:** Excess air in the combustion process.
- **Closed Loop:** When the ECU corrects the injector pulsewidths to obtain air-fuel ratios from the “Desired Air-Fuel Ratio Table,” it is operating in closed loop mode.
- **Open Loop:** When the ECU is not trying to correct to the “Desired Air Fuel Ratio Table,” it is operating in open loop mode.

**A few factors control the manner in which the TECgt200 alters the air-fuel ratio:**

#### EGO Parameters

- **EGO Feedback Control Activation:** This defines whether or not the oxygen sensor is set for closed-loop operation.
- **Coolant Temp. Above Which EGO is Enabled:** Allows the EGO to be turned off on cold engines. This is necessary because the EGO sensor must warm up before its readings are accurate.

#### EGO Reactivity and Authority

- **Instantaneous AFR Error Divisor:** Defines the size of the injector pulse width modifications when instantaneously large errors occur in the AFR (termed the “instantaneous error”). Large numbers for this parameter cause small pulse width modifications. Small numbers for this parameter cause large pulse width modifications. This number is used to control engine speed oscillation. Increasing this number generally helps to reduce oscillation associated with changing AFR’s.
- **Number of Samplings for Avg. Error:** Defines the size of the injector pulse width modifications when the EGO reading is changing slowly (termed the “average error”). A small number in this parameter causes large pulse width modifications. A large number for this parameter causes small pulse width modifications.
- **Number of Cylinder Events Between Samplings:** Defines the number of injector firings that will occur before the EGO obtains a new sample. This allows fuel to travel through the engine with the modified pulsewidths before the EGO reading is taken again. Larger numbers make the EGO corrections slower.
- **Authority Range for EGO:** Defines the percentage that the EGO function is capable of adding or subtracting from the “VE Absolute” value.

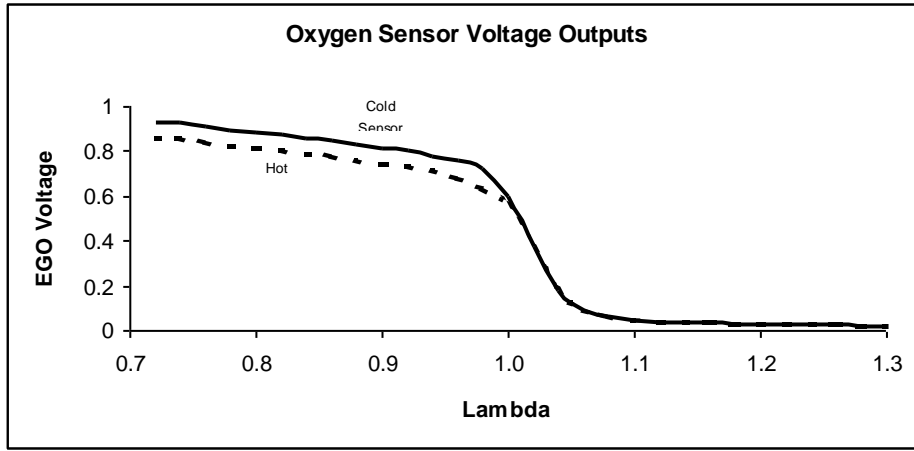
### EGO Programmable Deactivation

- **High MAP Switch Above Which EGO is Disabled:** Allows the EGO to be turned off above a specific MAP point. The system goes into open-loop mode above this MAP point, but returns to closed loop below this point.
- **RPM Above Which MAP Switch is Active:** Defines the RPM above which the High MAP switch is active. If the MAP reading exceeds the value in the “High MAP Switch,” but this RPM is not exceeded, the system will remain in closed-loop mode.
- **RPM Below Which EGO is Disabled:** Turns off closed-loop operation when the engine falls below this RPM. The TPS reading must be below the Closed Throttle Voltage for this parameter to be engaged. This parameter is used for exhaust systems that cannot create enough heat at idle for the EGO sensor to be accurate.

### **A few things to remember:**

- Standard oxygen sensors are designed to provide a **switch-point** for stoichiometric air-fuel operation. They are NOT designed to be able to tell you the exact air-fuel ratio when you are outside the stoichiometric amount (14.64:1 AFR).
- Oxygen sensors have a large degree of inaccuracy when operated at different temperatures. **Figure 98** shows a characteristic voltage curve variation with EGO sensor temperature.
- Do not use an EGO authority range that is greater than 10% on a tuned engine. A correction greater than a ten percent increase or decrease to the fuel curve should never be necessary on a tuned engine.
- It is strongly recommended that the High MAP Switch reading be set to a value **BELOW** 95kPa. This will turn off the oxygen sensor correction at full-load conditions. It will save an engine from having a lean-out condition due to the oxygen sensor reading. Never run a boosted engine in closed-loop during high-boost situations.
- Oxygen Sensors need heat to operate correctly. Readings obtained at idle are often inaccurate due to this fact.
- Although much faith is placed on air-fuel measurement, it is not the sole determining factor for proper engine operation and fuel metering. Unless you know a specific engine’s air-

fuel requirements, there is no “target” air-fuel ratio to shoot for. However, ALWAYS run engines on the rich side of stoichiometric when under medium to high load.



**Figure 98:** Typical oxygen sensor voltage variation with exhaust temperature.

### 9.1.12 Warm-Up Enrichments (Coolant Temperature-Based)

Since engines need more fuel when the block, valves, cylinder head, and intake manifold are cold, a coolant temperature-based enrichment curve is included in the software. The coolant temperature enrichment serves the same function as the choke plate on a carburetor. This parameter has the ability to provide different fuel enrichments for different coolant temperatures. If the engine is operating substantially above the thermostat value, the coolant temperature enrichment can be used to add fuel to help cool down the engine.

If a cold engine is running rough (misfiring), but not blowing black smoke from the exhaust, the coolant temperature enrichment likely needs to be increased. If a cold engine is blowing black smoke out the exhaust, the coolant temperature enrichments should be decreased at the problem temperature. **Figure 99** is a fairly typical coolant enrichment curve.

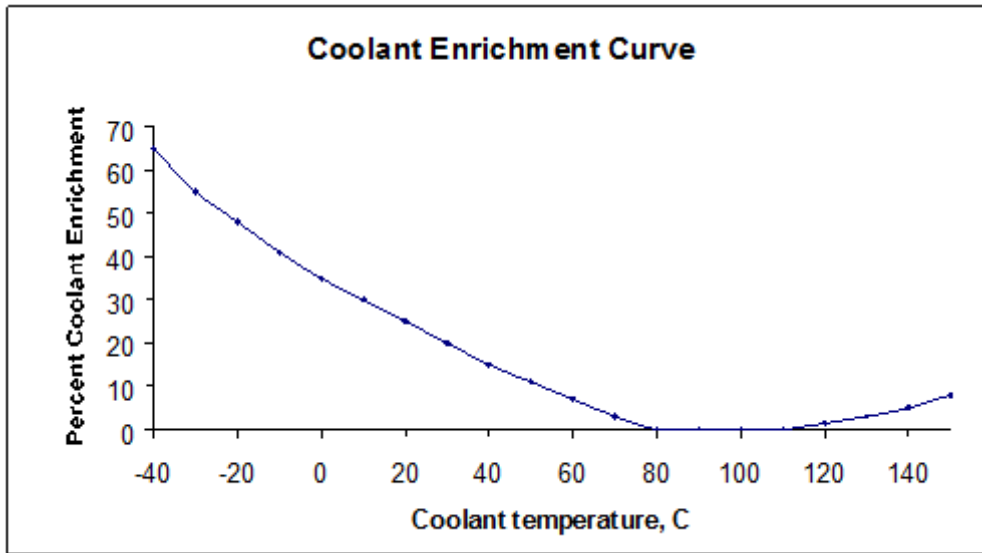
When the warm-up enrichment is in effect, its percentage of enrichment adds directly to the VE “Absolute” correction. Therefore, if the VE Absolute is 90% at a given point, and the coolant enrichment was 20%, the effective VE Absolute correction would be 110%. Fittingly, the pulse width equation must be modified to reflect this enrichment. It now becomes:

$$\text{Pulse Width} = [(\text{MAP Voltage} \div 5) \times \text{TOG} \times \{(\text{VE “Absolute” \%} + \text{CLT}) \div 100\}] + \text{IOT}$$

The same calculation method is used for both the EGO and MAT enrichments, which are outlined in subsequent sections.



**Figure 99:** A typical coolant enrichment curve.

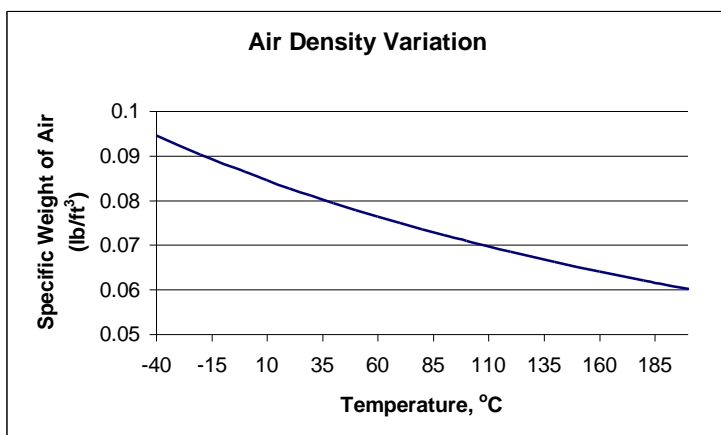


### 9.1.13 Manifold Air Temperature Enrichments

Just as the coolant temperature sensor provides engine temperature-based enrichments, the manifold air temperature sensor allows for air temperature-based enrichments. Since air becomes denser as it gets colder, it requires more fuel to maintain a specific air/fuel ratio. In fact, at  $-40^{\circ}\text{F}$  ( $-40^{\circ}\text{C}$ ), air is 25% denser than at  $70^{\circ}\text{F}$  ( $21^{\circ}\text{C}$ )! All things being equal, this means that the engine would require 25% more fuel at  $-40^{\circ}\text{F}$  than at  $70^{\circ}\text{F}$ . Look at **Figure 100** to see the dependence of temperature on air density.

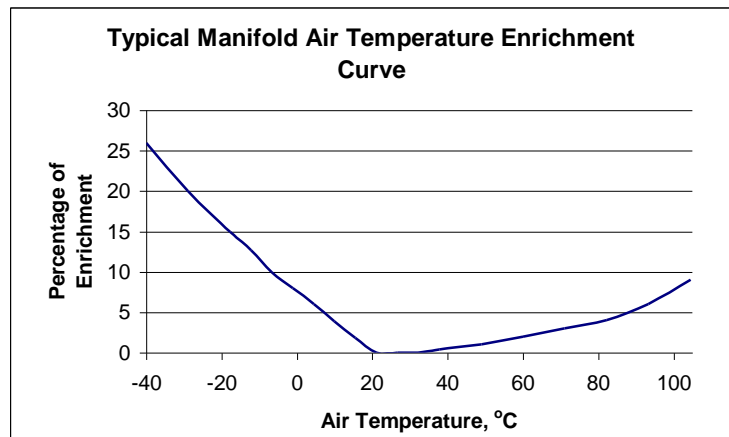
Since the majority of engines will run MAT readings at around  $70^{\circ}\text{--}100^{\circ}\text{F}$  ( $20^{\circ}\text{--}40^{\circ}\text{C}$ ), **Figure 101** shows a recommended MAT enrichment curve. Note that the MAT enrichment is zeroed around the normal operating temperatures. This is a good idea, because it eliminates one more variable from the tuning process on a fully-warmed-up engine.

Please note that the MAT enrichment increases at very high MAT readings in **Figure 101**. This is a safety precaution that is in place to reduce the tendency for an engine to detonate with excessive air temperatures. Turbocharged engines should definitely use the high air temperature enrichments. Naturally aspirated engines that are fairly detonation-resistant may want the MAT enrichment to go slightly negative with increasing temperature. Keep in mind, however, that even a well-designed engine can experience detonation issues when air charge temperatures get too high.



**Figure 100:** Air Density vs. Temperature

**Figure 101:** Recommended Starting MAT enrichment curve for turbo-charged applications.



### 9.1.14 Throttle Position Sensor and MAP Enrichments

The TPS acceleration enrichments provide extra fuel when the throttle is quickly depressed, just like the accelerator pump on a carburetor. Similarly, the MAP sensor rate-of-change enrichments provide fuel enrichments when the manifold pressure changes quickly. Most engines will only need TPS-based acceleration enrichments to run properly. A few factors govern the TPS- and MAP-based acceleration enrichments:

- **Throttle Position Rate of Change Enrichment Activation:** When this is turned on, the TPS will be used as the device to trigger the Acceleration Mode.
- **MAP Rate of Change Enrichment Activation:** When this is turned on, the MAP sensor will be used as the device to trigger the Acceleration Mode.

#### Sensitivity

- **TPS Rate of Change Sensitivity (ACE-0):** Defines the speed (in volts per second) at which the TPS must be moved in order for the TPS acceleration enrichments to be activated (referred to as *TPS Acceleration Mode*). Since the units are in volts/sec, smaller numbers make the TPS enrichments more sensitive to throttle position changes.
  - **MAP Rate of Change Sensitivity (ACE-1):** Defines the speed (in kPa per second) at which the MAP reading must change in order for the MAP acceleration enrichments to be activated (referred to as *MAP Acceleration Mode*). Since the units are in kPa/sec, smaller numbers make the MAP enrichments more sensitive to MAP changes.
- The **TECgt200** will only enter into either TPS *or* MAP Acceleration Mode (not both at the same time). TPS Acceleration Mode always takes precedence to MAP Acceleration Mode. Thus, if the TPS Rate of Change Sensitivity level is reached while in MAP Acceleration Mode, the **TECgt200** will change to TPS Acceleration Mode. However, with the exception of ACE-6, both MAP and TPS Acceleration Modes are identical.

#### One Second Acceleration Enrichments

- **Temperature-Based One Second Acceleration Enrichment (ACE-2):** The full value of this fuel enrichment is added when the Acceleration Mode is engaged and the coolant temperature is -40C. The enrichment ramps down to zero once the coolant temperature has reached +80C. This enrichment only adds fuel for a period of 1 second once the

Acceleration Mode is engaged. The enrichment value is added to the “VE Absolute” number. Use this parameter only after ACE-3 has been established on a fully warmed-up engine.

- **Constant One Second Acceleration Enrichment (ACE-3):** This enrichment is added for a period of one second after the Acceleration Mode has been engaged. The enrichment value is added to the “VE Absolute” number.

### Variable Time Acceleration Enrichments

- **Time for Variable Time Acceleration Enrichments (ACE-4):** This number defines the amount of time that the variable time acceleration enrichments will be added. Use the variable time acceleration enrichments when the engine requires fuel enrichments for either a longer or shorter amount of time than the One Second Acceleration Enrichments can provide. The enrichment value is added to the “VE Absolute” number.
- **Decaying, Variable Time Acceleration Enrichment (ACE-5):** The full value entered in this enrichment will be added when the acceleration mode has been engaged. The enrichment value will then decay to zero once the ACE-4 value has been reached. This enrichment value is added to the “VE Absolute” number.
- **Manifold Pressure Rate of Change Enrichment (ACE-6):** When the MAP Acceleration Mode has been activated, this enrichment will add fuel based on the rate at which the MAP reading is changing. The full value of this enrichment will be added when the MAP reading changes by

1.65kPa/ms on a 1-Bar sensor, or  
3.50kPa/ms on a 2-Bar sensor, or  
5.43kPa/ms on a 3-Bar sensor.

When the MAP reading changes by less than these rates, the full value of this enrichment is not added. Instead, a percentage of the full value is added, normalized to 0% at 0.00kPa/ms MAP sensor rate of change. The value of this enrichment is added for a time of ACE-4 milliseconds (it does NOT decay to zero). This enrichment is added to the “VE Absolute” number.

- **Constant Variable Time Acceleration Enrichment (ACE-7):** Functions similarly to ACE 5, but instead of the enrichment decaying with time, it is constant for the full ACE-4 number of seconds. The enrichment value is added to the “VE Absolute” number.

### Variable Time Injector Pulse Width Enrichments

- **Fixed Pulse Width Enrichment (ACE-8):** Adds a fixed fuel injector pulse width to the current pulse width once the Acceleration Mode is engaged. This number adds to the Injector Offset Time (IOT).
- **Time to Add the Fixed Pulse Width Enrichment (ACE-9):** This number sets the amount of time that ACE-8 adds to the injector pulse width when the Acceleration Mode is engaged.

## 9.1.15 Starting Enrichments

### One Second Starting Enrichments

- **Temperature-Based One Second Starting Enrichment (SE-0):** This enrichment adds to the injector pulse width for a period of one second after the **TECgt200** detects engine cranking. The full value of this enrichment is added at –40C coolant temperature. The

enrichment ramps down linearly to zero when the coolant reaches 80C. The enrichment value entered here is added to the “VE Absolute” value.

- **Constant One Second Starting Enrichment: (SE-1):** This enrichment adds to the injector pulse width for a period of one second after the **TECgt200** detects engine cranking. The enrichment value entered here is added to the “VE Absolute” value.
- **Fixed One Second Starting Pulse Width Addition (PW-0):** This enrichment adds a fixed amount of pulse width to the injectors for a period of one second after the **TECgt200** detects engine cranking. This number is only added when the coolant temperature is below CLT-0. PW-0's value is added to “IOT.”
- **Coolant Temperature Below Which PW0 is Activated (CLT-0):** This number determines the coolant temperature below which PW-0 will add its pulse width value.

### Twenty Second Starting Enrichments

- **Temperature-Based Twenty Second Starting Enrichment (ASE-0):** This enrichment adds extra fuel for a period of 20 seconds after the engine has been started. The full amount of this enrichment is added at –40C. The enrichment value ramps down to zero when the coolant reaches 80C. The enrichment value entered here is added to the “VE Absolute” value.
- **Constant Twenty Second Starting Enrichment (ASE-1):** This enrichment adds extra fuel for a period of 20 seconds after the engine has been started. The enrichment value entered here is added to the “VE Absolute” value.

### Fuel Pump Turn-On Time

- **Set Constant for the Fuel Pump Turn-On Time:** This feature is used to turn the fuel pump on when the ignition is turned on. The fuel pump will run for the specified number of seconds, or until engine cranking occurs. Use this value to prime your fuel system.

## 9.1.16 Battery Voltage Compensation

Fuel injectors generally require a longer pulse width at low battery voltage. Low battery voltages cannot move the injector pintle as quickly as normal battery voltages, which thereby creates a lean condition during low voltage operation. The amount of fuel enrichment that is needed for low battery voltage is usually very small.

Parameter BT0 (Injector Pulse Width Compensation for Low Battery Voltage) sets the amount of additional pulse width that is used for low battery voltages. BT0 does not add pulse width until battery voltage drops below 12 volts. Once this occurs, it will add pulse width to the “TFPW” value.

Low resistance injectors do not suffer from the same low battery voltage effects as high resistance injectors. **High resistance injectors should not need BT0 to be set higher than 360µs/volt, while low resistance injectors should not need BT0 to be set higher than 180µs/volt.** Note that 1000µseconds = 1milliseconds. As such, a 360µs/volt setting on BT0 would add 0.360 milliseconds to the injector pulse width when the battery is at 11 volts.

The battery voltage parameter allow the **TECgt200** to adjust the injector open times up or down to compensate for low or high battery voltages. The value specifies how many microseconds to add or subtract to calculated open time based on the current battery voltage. The compensation value is specified in microseconds per volt. When the voltage is at 10 volts (2 volts low), and value in the software voltage compensation specifies 65 microseconds per volt,

the value added to the final injector pulse time will be 130 microseconds (65 microseconds per volt x 2 volts low).

1 ms = 1000 microseconds, so 65 microseconds = .065 ms.

If the voltage varies more than between 8 and 16 volts, an additional battery, additional alternator, or a more powerful replacement alternator should be considered.

### **9.1.17 Deceleration Fuel Cut-Off**

When an engine is rapidly decelerating, injected fuel will often cause backfiring through the exhaust. This occurs because the engine is not using much air or fuel, so any excess injected fuel hits the exhaust manifold and ignites. To eliminate this situation, the Deceleration Fuel Cut-Off allows the injectors to be turned off when the throttle is closed quickly.

**A few factors control the fuel cut-off:**

- **Deceleration Fuel Cut-Off Activation:** This parameter defines whether or not the **TECgt200** will go into Deceleration Fuel Cut-Off mode. Turn this ON to enable the fuel cut-off.

#### **RPM Limits of Activation**

- **Cold RPM Above Which DECEL Activates (DCCL-0):** This is the RPM above which the Deceleration Fuel Cut-Off mode is active when the coolant temperature is -40C. When above -40C, the RPM above which the Fuel Cut-Off is active is determined by drawing a straight line from DCCL-0 to DCCL-1. Once the RPM drops below this point, the injectors turn back on, and DCCL-4 is added for 1 second.
- **Hot RPM Above Which DECEL Activates (DCCL-1):** This is the RPM above which the Deceleration Fuel Cut-Off mode is active when the coolant temperature is 80C. When below 80C, the RPM above which the Fuel Cut-Off is active is determined by drawing a straight line from DCCL-0 to DCCL-1. Once the RPM drops below this point, the injectors turn back on, and DCCL-4 is added for 1 second.

#### **Throttle Position Rate of Change Sensitivity**

- **TPS Rate Above Which DECEL Activates (DCCL-2):** This is the rate at which the throttle must be moving to initiate the Deceleration Fuel Cut-Off, expressed in volts per second. A lower number is more sensitive, and will engage the Fuel Cut-Off more readily than a higher number.

#### **Manifold Air Pressure Activation**

- **MAP Reading Below Which DECEL Activates (DCCL-3):** The Deceleration Fuel Cut-Off is only activated when the MAP reading drops below this value.

#### **Post Deceleration Enrichment**

- **One Second Enrichment After DECEL Ends (DCCL-4):** This enrichment is added for one second after the **TECgt200** comes out of Fuel Cut-Off mode. This is intended to help wet down the intake tract walls that were dried off under deceleration. The value of this enrichment is added to the "VE Absolute" number.

## 9.1.18 Summary

If you have made it through the preceding pages of discussion on Injector Pulse Width Derivation, you should have a good grasp on the entire functionality behind tuning a fuel injected vehicle...hopefully, you are still awake and of sound mental health!

Since there are so many enrichments that affect the injector pulse width calculation, it is sometimes hard to find the exact pulse width at a given instant in time. For this reason, the WinTec software displays a value called “**Total Fundamental Pulse Width Percentage (TFPW).**” This value is an absolute reading, so when the engine is operating at 100% TFP, it is running at the pulse width defined by the raw fuel curve, with no other enrichments. When the TFP value is less than 100%, the fuel injector pulse width is lower than the value defined by the raw fuel curve. When the TFP is greater than 100%, the fuel injector pulse width is higher than the value established by the raw fuel curve.

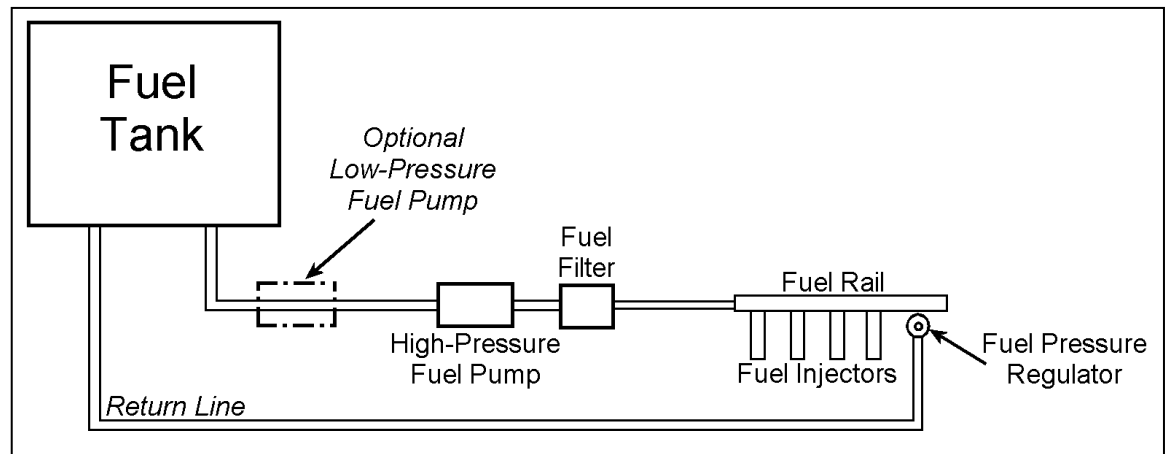
Tuning a fuel curve to reflect every situation of everyday driving is a large task that, at times, can be a bit frustrating. However, great lengths have been taken to ensure complete tunability for most situations that may arise in extreme driving environments. The Tuning Guide of this manual uses the points learned in this section to arrange the engine tuning procedure into simple one-step-at-a-time tasks.

## 10 Fuel System

A poorly designed fuel system will result in fuel delivery problems. There are a few common mistakes that are easy to avoid by following the recommendations in this section. See **Figure 104** for a typical fuel system layout.

- If the high-pressure fuel pump is mounted ABOVE the fuel level in the gas tank, a low-pressure transfer pump should be installed before the high-pressure pump. A fuel pump designed for a carbureted application should be used for the transfer pump (do not use a TBI-style pump as a transfer pump). High-pressure pumps often burn out when required to draw suction. Most low-pressure pumps are designed to be able to pull a good amount of suction without failure. Use a fuel pump designed for a carburetor when selecting a low-pressure pump.
- Fuel pumps that are internal to the gas tank will often last longer than external pumps. However, care should be taken to ensure that an in-tank pump is capable of flowing enough fuel for a given application.
- Reference the vacuum port on the fuel pressure regulator to intake manifold vacuum/pressure. On highly boosted engines, the hose should be secured with a zip tie or wire.
- The fuel pump power should be fused. For proper fuse selection, it is necessary to know the amperage draw of the fuel pump. Typically, a 10amp fuse will be adequate for most applications.

**Figure 104:**  
Fuel system  
plumbing.



## 10.1 Injector Sizing

The most important component of the fuel system is the fuel injector. Injectors must be flow matched to maintain a consistent fuel supply for all cylinders. Cylinder-to-cylinder fuel variations can lead to poor performance, increased fuel consumption, or even catastrophic detonation. Additionally, the size of the injector plays a large role in tuning a vehicle. Injector sizes (flow rates) are generally given in either pounds-per-hour (lbs/hr) or cubic centimeters per minute (cc/min). (Note that 1 lb/hr = 10.5 cc/min.) These ratings are either made by the injector manufacturer or by an aftermarket injector modifier. In either case, the importance of the pressure at which the flow rating was obtained must be realized. As an example, an injector that was rated at 40 lbs/hr at 43.5psi pressure will NOT supply 40 lbs/hr when operated at 30psi...it will flow more like 34 lbs/hr.

For an injector to be “sized” properly for an engine, a few things must be taken into consideration:

- Number of Cylinders
- Number of Injectors
- Engine Horsepower
- Peak RPM
- Brake Specific Fuel Consumption (BSFC)
- Injector Recovery Time (IRT)

The Brake Specific Fuel Consumption (BSFC) is a scaling factor used for fuel flow calculations. Its units are pounds-per-hour per horsepower (lbs/hr per HP). Typically, gasoline engines run BSFC's between 0.40 and 0.60. Alcohol engines generally run BSFC's between 0.80 and 1.20. A lower BSFC value indicates a more efficient engine. The original 4-cylinder BMW M3 engine has a BSFC of around 0.43, while some rotary turbo engines approach 0.60 BSFC. A turbo engine will normally have a BSFC above 0.5.

### Example:

Engine Horsepower = 300  
BSFC = 0.50  
 $300 \text{ HP} \times 0.50 \text{ lbs-per-hr/HP} = 150 \text{ lb/hr}$   
This engine would require a total of **150 lbs/hr** of fuel flow.

The Injector Recovery Time is the time that it takes for an injector to open once it receives a voltage signal. Typically, a low-impedance injector will have an IRT of around 1.3 milliseconds. A high impedance injector will generally have an IRT of 1.5 ms. This number determines two things:

- The minimum time that the injector can be pulsed
- The maximum duty cycle

If an injector is given a pulse width that is shorter than its IRT, it will flutter. This will cause erratic fuel metering, and ultimately horrible engine performance. This scenario sometimes occurs at idle on high-revving, high-horsepower engines with large injectors. If the IRT is not accounted for in high-rpm situations, the duty cycle will be too great, and the injector will flutter. This scenario occurs on engines with injectors that are too small.

To properly size an injector, the following sequence of equations should be followed:

- $HP \times BSFC = \text{Total Fuel Flow Requirement for the Engine (TFFR)}$
- $TFFR \div (\# \text{ of Injectors}) = \text{Uncorrected Injector Size (UIS)}$
- $60000 \div (\text{Peak RPM}) = \text{Available Injection Time (ms) per Revolution (AIT)}$
- $(AIT - \text{Injector Recovery Time in ms}) \div AIT = \text{Maximum Duty Cycle (MDC)}$
- $UIS \div MDC = \text{Required Injector Size}$

The above calculation assumes an injection scenario in which an injector is held open for a maximum of one engine revolution (typical phase sequential setup). For other firing options in which the injector is held open for 2 revolutions, multiply AIT by 2.

#### Example:

Engine Setup: 500HP 8-cylinder with 8 injectors  
Phase Sequential Injector Firing  
High Impedance Injectors (1.5ms IRT)  
Peak HP occurs at 6500 rpm  
BSFC = 0.5

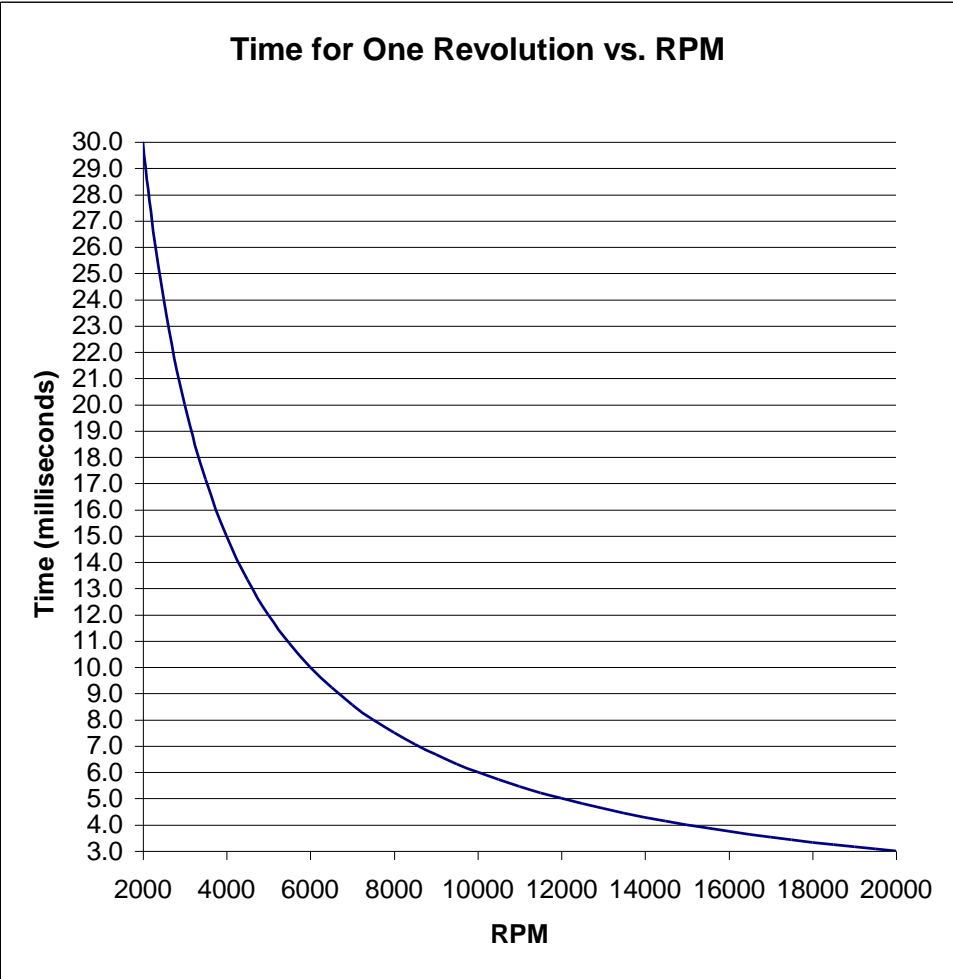
#### Calculations:

$TFFR = 500 \times 0.5 = 250 \text{ lb/hr}$   
 $UIS = 250 \div 8 = 31.25 \text{ lb/hr}$   
 $AIT = 60000 \div 6500 = 9.231 \text{ ms}$   
 $MDC = (9.231 - 1.5) \div 9.231 = 0.8375$   
Required Injector Size =  $31.25 \div 0.8375 = \mathbf{37.3 \text{ lb/hr (392 cc/min)}}$

Central to the topic of injector sizing is the RPM at which the engine will need the injectors to fire. High RPM's shorten the amount of time between TDC events, thus shortening the maximum injector pulse width. **Figure 105** shows the time per revolution as a function of RPM. **Table 10** shows the peak injector pulse width (assuming an injector recovery time of **zero**) that is possible using both once-per-revolution firing and once-per engine-cycle (2 revolutions on a 4 stroke) firing modes. If the operating pulse width approaches the values in **Table 10**, the injectors are effectively "maxed-out." Larger injectors would be necessary if the engine needed more fuel. Note that the injector recovery time will be at least 1.0ms in practice. Consequently, the values



given in **Table E.1. 1** should have 1.0ms subtracted from them to determine the actual pulse width peak.



**Figure 105:** Time between revolutions for various engine speeds.

**Table 10:** Peak injector pulse widths for phase- and full-sequential injector firing. Injector recovery time of zero is assumed.

<b>RPM</b>	<b>Phase Sequential (1 inj. per rev.) (ms)</b>	<b>Full Sequential (1 inj. per 2 rev.) (ms)</b>
0	-	-
500	120.0	240.0
1000	60.0	120.0
1500	40.0	80.0
2000	30.0	60.0
2500	24.0	48.0
3000	20.0	40.0
3500	17.1	34.3
4000	15.0	30.0
4500	13.3	26.7
5000	12.0	24.0
5500	10.9	21.8
6000	10.0	20.0
6500	9.2	18.5
7000	8.6	17.1
7500	8.0	16.0
8000	7.5	15.0
8500	7.1	14.1
9000	6.7	13.3
9500	6.3	12.6
10000	6.0	12.0
10500	5.7	11.4
11000	5.5	10.9
11500	5.2	10.4
12000	5.0	10.0
12500	4.8	9.6
13000	4.6	9.2
13500	4.4	8.9
14000	4.3	8.6
14500	4.1	8.3
15000	4.0	8.0
15500	3.9	7.7
16000	3.8	7.5
16500	3.6	7.3
17000	3.5	7.1
17500	3.4	6.9
18000	3.3	6.7
18500	3.2	6.5
19000	3.2	6.3
19500	3.1	6.2
20000	3.0	6.0

## 10.2 Fuel Pump Selection

When choosing a fuel pump, two factors are important:

- Flow Rating (in lbs/hr)
- Pressure Rating (in psi)

To find the flow rating required for a given engine, multiply the engine horsepower by the BSFC, and add at least 25%.

### Example:

$$\begin{aligned} & 400 \text{ HP Engine w/ } 0.50 \text{ BSFC} \\ \text{Fuel Pump Required} &= (400 \times 0.50) + (400 \times 0.50 \times .25) = \mathbf{250 \text{ lb/hr minimum}} \end{aligned}$$

As for the pressure rating, a minimum of 70psi is typically used for multi-port injection layouts. Fuel pumps for TBI setups can be rated lower, since the operating rail pressure is lower with TBI injectors.

High-boost (over 20psi) applications may suffer from problems with normal OEM fuel pumps. Since many fuel pumps are rated at 43psi (3-Bar), there is no information on what the pumps will flow at 60 or 70psi. On a turbo engine with 25psi boost, the fuel pump will see about 68psi. Most stock fuel pumps will not be able to maintain their flow rating at this pressure, and a lean-out condition may result. As such, it is highly advised that you buy a good quality aftermarket pump when running highly boosted engines.

If a high-pressure pump is mounted above the fuel level in a gas tank, a decreased pump lifespan will generally result. Some high-pressure pumps will fail very quickly when mounted above the fuel level. The reason for this failure is that high-pressure pumps often are not designed to pull suction. As such, any high-pressure pump mounted above the fuel level should have a low-pressure fuel pump before it. A standard carburetor-style fuel pump can be used for this task.

## 10.3 Fuel Pressure Regulator Selection

Unlike a stock OEM computer, the **TECgt200** generally does not require an adjustable fuel pressure regulator. The reason for this is quite simple: the **TECgt200** allows you to set the precise fuel injector pulse width for a given RPM/load point. In so doing, you do not need to change the fuel pressure to change the amount of fuel introduced into the cylinders; you simply need to change the injector pulse width.

There are, however, some guidelines to be followed for selecting a regulator. When you select the injector size needed for an engine, you will need to know the pressure for which the flow rate was established. Typically, injector sizes are rated at 3-Bar or 43.5psi. Therefore, an injector rated at 55 lb/hr at 43.5psi will only flow 55 lb/hr *when it is at 43.5psi*. More accurately, it will only flow 55 lb/hr when the *pressure gradient* across the injector is 43.5psi.

The pressure gradient is defined as the difference between the injector spray tip pressure (this is generally the same as the intake manifold pressure) and the fuel rail pressure (often referred to as “gauge pressure”). For a naturally aspirated engine at idle making 15” of Hg (about -7.5psi) vacuum, you will need to decrease your fuel rail pressure by 15” of Hg (about -7.5psi) to obtain the same pressure gradient across the injector. So for the 55 lb/hr injector to actually flow 55 lb/hr when the manifold is under -7.5psi vacuum, you will need to decrease the fuel rail pressure by 7.5psi. The rail pressure should therefore be reduced from 43.5psi to 36psi.

The same holds true for engines under boost: for an engine with 10psi of boost pressure in the intake manifold, the injectors will need to have 10psi added to the fuel rail pressure. The fuel rail pressure would then have to be 53.5psi.

Though this all may sound complicated, maintaining a constant pressure gradient sounds more difficult than it really is. Since 99% of all fuel pressure regulators have a vacuum hose port on them, all you need to do is run a vacuum hose from your intake manifold (after the throttle) to the regulator. On boosted applications using a draw-through throttle, place the vacuum hose after the turbo compressor. To be totally accurate, the vacuum/boost reference for the port on the regulator should be experiencing the same vacuum/boost as the injector tip. Plumb the hose accordingly.

Be aware that when you use a fuel pressure regulator that regulates the fuel pressure to a value that is not the same as the fuel injector flow rating pressure, the injector will no longer run at it's rated flow. That is, higher pressure will cause a higher flow rate. To keep things straightforward, try to run the fuel pressure for which your injectors are rated. Electromotive offers several regulators with different pressure ratings to make your search as easy as possible.

### 10.3.1 Absolute vs. Gage Pressure

A MAP sensor is an absolute sensor. This means that its readings are referenced to a full vacuum. As such, the lowest reading attainable on a MAP sensor would be a full vacuum. (In practice, however, most MAP sensors only go down to about 10kPa. Gauge pressure is referenced to ambient atmospheric pressure. When we say that an engine is running 15psi (103kPa) of boost, it means that the intake manifold is seeing 15psi of positive pressure. Since standard atmospheric pressure is approximately 14.7psi (101.3kPa), the absolute manifold pressure for this engine would be 29.7psi (205kPa or about 2 Bar). Thus, a 2-Bar sensor is necessary for this engine. Refer to the formula below if you are confused about the difference between gauge and absolute pressure.

#### Ambient (atmospheric) Pressure + Gauge Pressure = Absolute Pressure

- When discussing absolute pressure, there is no distinction made between vacuum and pressure.
- When discussing gauge or relative pressure, vacuum readings will be negative values and boost readings will be positive. Alternatively, in the US measurement system, vacuum readings can be expressed in inches of Mercury and boost can be expressed in pounds per square inch.

### 10.3.2 Units of Measurement

In the US, units of vacuum are typically measured in inches of mercury (in-Hg). Units of pressure are typically measured in pounds per square inch (psi). Since there is a distinction made between vacuum and pressure readings, these units are generally not used for absolute measurements.

In most other countries, the metric system is used for pressure measurements. In this system, the kilopascal (kPa) is the standard unit of measurement. The distinction must be made to whether the measurement is in absolute kPa or gauge kPa. Typically, this is done by writing "kPa, abs" for the former, and "kPa, gauge" for the latter. For the purposes of this section, we will treat all kPa reading as *absolute* readings. **Table 11** gives conversion data for US and metric units. Remember:

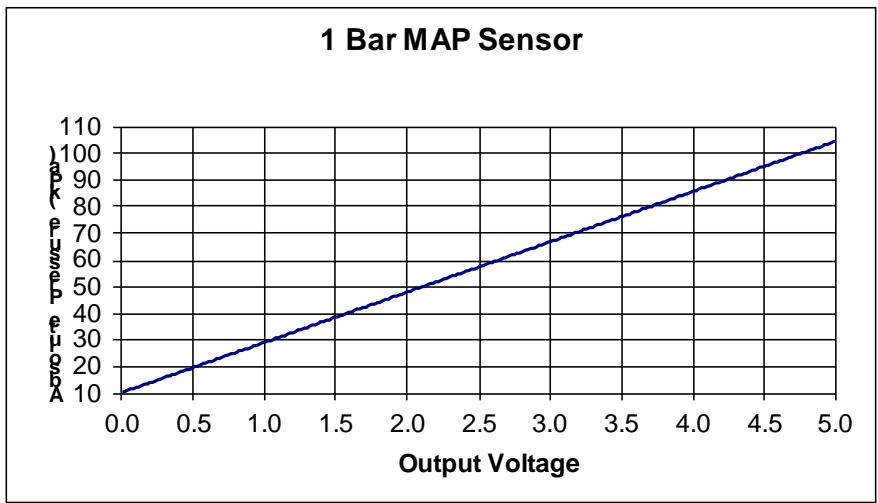
**Ambient (atmospheric) Pressure + Gauge Pressure = Absolute Pressure**

- 1psi = 6.895 kPa
- 1 in-Hg = 3.377 kPa
- 1 Bar = 101.3kPa, abs = 0psi, gauge
- 2 Bar = 202.6kPa, abs = 14.7psi, gauge
- 3 Bar = 303.9kPa, abs = 29.4psi, gauge

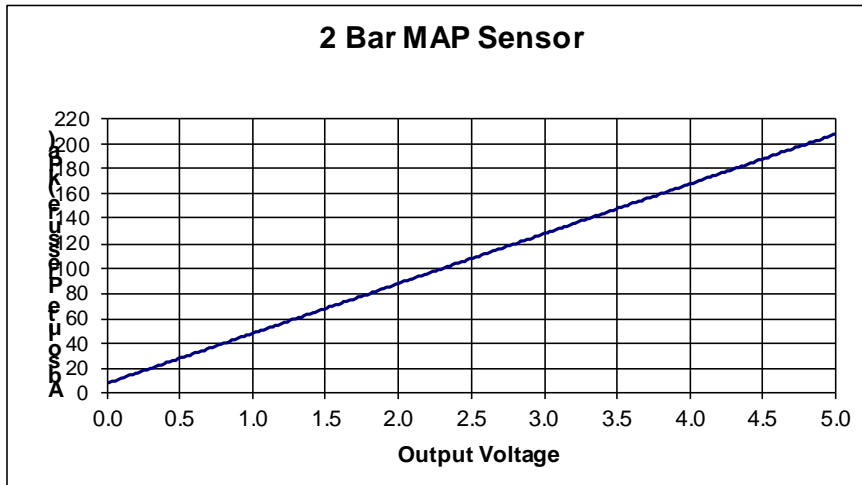
**Table 11:** US to metric unit conversion data.

kPa Absolute	in-Hg/psig Gauge
0	29.9 in-Hg
10	27.0 in-Hg
20	24.0 in-Hg
30	21.1 in-Hg
40	18.1 in-Hg
50	15.2 in-Hg
60	12.2 in-Hg
70	9.28 in-Hg
80	6.31 in-Hg
90	3.35 in-Hg
100	0.39 in-Hg
110	1.26 psi
120	2.71 psi
130	4.16 psi
140	5.61 psi
150	7.06 psi
160	8.51 psi

kPa Absolute	in-Hg/psig Gauge
170	10.0 psi
180	11.4 psi
190	12.9 psi
200	14.3 psi
210	15.8 psi
220	17.2 psi
230	18.6 psi
240	20.1 psi
250	21.6 psi
260	23.0 psi
270	24.4 psi
280	25.9 psi
290	27.4 psi
300	28.8 psi
310	30.3 psi
320	31.7 psi
330	33.2 psi

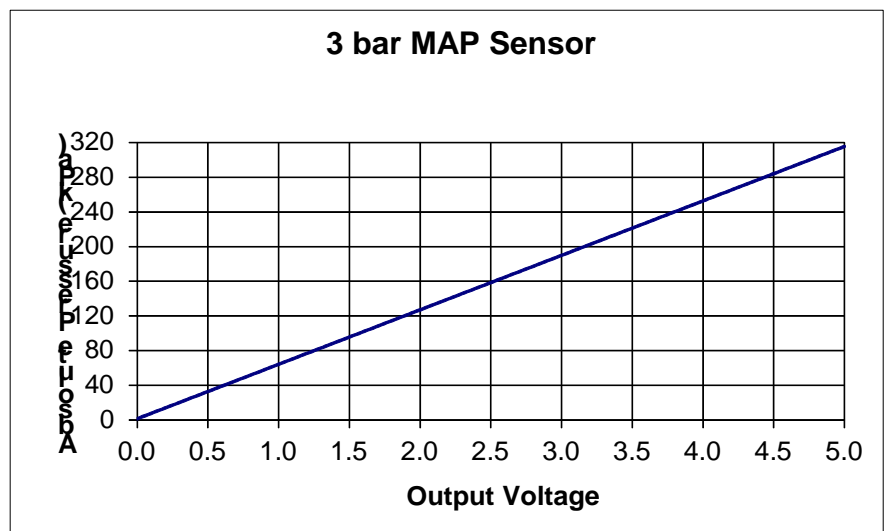


**Figure 106:** 1-Bar MAP sensor output voltage.



**Figure 107:** 2-Bar MAP sensor output voltage.

**Figure 108:** 3-Bar MAP sensor output voltage.



## 11 Diagnostics

The **TECgt200** has two provisions for diagnostics: an output wire for a “check engine” light and an LED on the ECU. The two outputs perform different tasks that are outlined below.

### 11.1 Trouble Codes from the LED’s Mounted on the TECgt200

The LED’s mounted on the **TECgt200** are used to alert the user’s attention to electrical and crank trigger problems. They are also used to show the mode (in terms of the rpm range) in which the **TECgt200** is operating. Here are the readings from the LED’s :

- **Turn ignition key on (but do not start engine):**  
 Upper LED goes steady green :  
     Good, the processors are getting power.  
 Upper LED does not turn on at all :

Either the **TECgt200** is not receiving +12V power from pin (A), or the ECU has an issue.

- **Engine cranking (below 400 rpm):**  
Lower LED changes color from red to green every other revolution:  
    Good, the crank sensor is working correctly  
Lower LED does not change colors:  
    The crank sensor is not functioning properly (signal is not being picked up).
- **Engine running (over 400 rpm):**  
Lower LED is steady green:  
    Good, the crank trigger is functioning properly.  
Lower LED flashes red every so often:  
    The **TECgt200** is getting a bad signal from the crank trigger. The engine most likely misfires whenever the light flashes red.
- **Engine is Hitting Rev Limiter:**  
Lower LED changes color turns orange:  
    The first or second stage of the rev limiter is occurring.  
Lower LED turns red:  
    The third (and final) rev limiter stage is occurring.

**Note:**

If a misfire occurs during normal engine operation, but the lower LED on the **TECgt200** was not observed to momentarily flash red, the crank sensor may be at fault. To test for errors in this situation, turn the engine off without removing power from the **TECgt200** ECU (this can be accomplished by unplugging the fuel injector harness, or by hitting the letter “K” from the engine monitor screen when using a laptop). If the lower LED is flashing red after the engine is shut off, there was a crank sensor problem at some point during the run.

## 11.2 Trouble Codes from the Check Engine Output

The trouble codes from the check engine output are related to the engine sensors. If the check engine output wire is connected to a light bulb, it will display a sequence of flashes depending on the problem. The diagnostic codes are arranged such that there are two digits for each code. The check engine light will give long duration flashes for the first digit of the code and short duration flashes for the second digit. Here are the diagnostic codes (asterisked items are not available with the first software release):

- 12: Crank Trigger Error
- 13: Cam Trigger Error
- 14: ECU Internal Failure\*
- 21: Throttle Position Sensor High
- 22: Throttle Position Sensor Low
- 23: Manifold Air Pressure Sensor High
- 24: Manifold Air Pressure Sensor Low
- 25: Coolant Temperature Sensor High
- 26: Coolant Temperature Sensor Low
- 31: Manifold Air Temperature Sensor High
- 32: Manifold Air Temperature Sensor Low
- 33: High Battery Voltage

- 34: Low Battery Voltage
- 35: Knock too Long
- 37: Exhaust Gas Oxygen Sensor Lean too Long
- 38: Exhaust Gas Oxygen Sensor Rich too Long\*
- 41: GP I/O 6 Input High\*
- 42: GP I/O 6 Input Low\*
- 43: GP I/O 7 Input High\*
- 44: GP I/O 7 Input Low\*
- 45: GP I/O 8 Input High\*
- 46: GP I/O 8 Input Low\*
- 47: GP I/O 9 Input High\*
- 48: GP I/O 9 Input Low\*
- 51: GPO 1 Failure
- 52: GP I/O 3 Failure
- 53: GP I/O 4 Failure
- 54: GP I/O 5 Failure
- 61: Idle Speed Motor Driver Thermal Shutdown
- 62: Idle Speed Motor Driver Short to Battery or Open Load
- 63: Idle Speed Motor Driver Short to Ground

### 11.3 Trouble Code Descriptions

**Code 12 – Crank Trigger Error:** This code will register when the ECU has detected a problem with the crank trigger signal. If any of the failure scenarios have been detected in the section above on the crank sensor LED diagnostic, this code will be displayed

**Code 13 – Cam Trigger Error:** The ECU is not getting an appropriate signal from the cam sensor. A broken cam trigger wheel or a bad cam sensor could cause this error. This code will only be displayed on sequential applications.

**Code 14 – ECU Internal Failure:** This code is displayed when there has been a substantial failure inside the ECU. Call Technical support for further information.

**Codes 21 & 22 – TPS High/Low:** See above description.

**Codes 23 & 24 – Manifold Air Pressure High/Low:** These codes are set when the MAP sensor has gone outside its specified range. This can be useful for a boosted application to trigger a check engine signal when an over-boost situation has occurred. Alternately, it can be used to detect a short in the wires. When this code is displayed, the **TECgt200** will be using the MAP Failure Default value for MAP calculations. As such, there will be no load input to the **TECgt200's** ECU, and the computer will enter into a "limp-home" mode.

**Codes 25 & 26 – Coolant Temperature Sensor High/Low:** Once again, these codes are set when the coolant temperature reading is outside its specified range. Use this light to warn of coolant temperatures that are too high. When this code is displayed, the **TECgt200** will be using the CLT Failure Default value for coolant-based calculations. As such, there will be no engine temperature input to the **TECgt200's** ECU.



**Codes 31 & 32 – Manifold Air Temperature Sensor High/Low:** Works identically to codes 25 & 26, except for the MAT sensor.

**Code 33 – Battery Voltage too High:** The battery voltage has exceeded 17 Volts. This can be caused by a bad voltage regulator on the alternator.

**Code 34 – Battery Voltage too Low:** The battery voltage has gone below 7.5 Volts. Check the state of charge on the battery. Also check all power connections.

**Code 35 – Knock too Long:** The ECU has recorded a level of engine spark knock (from the knock sensor) for a duration that exceeds what was established in the software. This code is indicative of either poor fuel quality, or extreme engine temperatures leading to spark knock. Some tuning will be required for the knock sensor trouble codes, since all engines make noises that will trigger the knock sensor, but which are not caused by spark knock.

**Code 37 – EGO Lean too Long:** This code is set when the oxygen sensor reading is lean for a prolonged period of time. Make sure the sensor has not come unplugged.

**Code 38 – EGO Rich too Long:** This code is set when the oxygen sensor reading is rich for a prolonged period of time. Make sure the sensor is not shorted to +12 Volts.

**Codes 41&42, 43&44, 45&46, 47&48** all function like Codes 23&24, except they are for the Analog to Digital Inputs.

**Codes 51-54 – GP I/O 1-9 Failure:** These codes are set when the GP I/O input/outputs have been shorted to voltage or have been over-drawn (too much current). Make sure that the total circuit draw for GP I/O's 1-9 is less than 10 amps (1 amp per channel).

**Code 55 – Fuel Pump Output Failure:** The fuel pump output has seen an over-current situation, or is shorted to power.

**Code 56 – Check Engine Output Failure:** The check engine output has seen an over-current situation, or is shorted to power. The code can only be seen with a laptop, since the check engine light is likely at fault.

**Code 58 – Tachometer Output Failure:** The tachometer output has seen an over-current situation, or is shorted to power or ground.

**Code 61 – Idle Speed Control Thermal Shutdown:** The driver for the idle speed motor has been overheated. This can be caused by incorrect IAC motor wiring, or from a broken motor.

**Code 62 – Idle Speed Control Short to Battery or Open Load:** This code is set when the IAC driver has been shorted to voltage, or the motor has been unplugged.

**Code 63 – Idle Speed Control Short to Ground:** The IAC driver has been shorted to ground.

### 11.3.1 Using the Trouble Codes

The trouble codes are displayed for a sensor when the maximum or minimum value for a sensor has been exceeded. Since the maximum and minimum points are user-definable in the

WinTec software, a failure code does not necessarily indicate a failed sensor (i.e. the failure parameters may be set incorrectly).

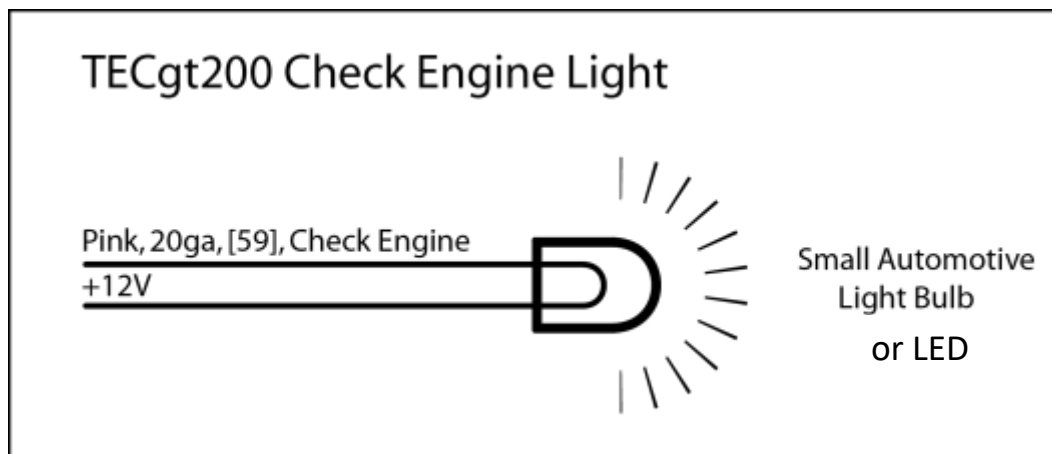
As an example, let's look at the Throttle Position Sensor Parameters. Before the parameters can be entered into the software, it is necessary to know the TPS voltage at both fully closed and wide open throttle. This can be observed in the monitor screen by opening and closing the throttle (without the engine running). If the closed throttle voltage was 1.0 volt and the wide open throttle voltage was 4.6 volts, the TPS parameters should be set as follows:

TPS Fully Closed Throttle Voltage:	1.1 Volts
TPS Wide Open Throttle Voltage:	4.5 Volts
TPS High Voltage Failure (0-5V):	4.8 Volts
TPS Low Voltage Failure (0-5 V):	0.8 Volts
TPS Failure Default Value (0-5V):	1.5 Volts

As can be seen, the **Fully Closed Throttle Voltage** setting is actually a bit above the actual closed throttle voltage ( $1.1V > 1.0V$ ). This is done because the Idle Speed Control will only start working when the TPS reading is below the **Fully Closed Throttle Voltage** setting. The **Low Voltage Failure** setting is made a few tenths of a volt lower than the actual closed throttle voltage ( $1.0V > 0.8V$ ). This is done to display code 22 for throttle position sensors that have either rotated in their mount or have failed completely by outputting a lower-than-expected voltage. Likewise, the **High Voltage Failure** setting is made a few tenths of a volt higher than the observed wide open throttle voltage. This will allow code 21 to be displayed in the event of a high voltage failure. The **Failure Default Value** is the voltage that the **TECgt200** will use for its TPS-based calculations when the TPS sensor has failed. Since this is a fixed value, there will be no TPS-based acceleration enrichments when the TPS has failed. However, the Failure Default Value is useful for applications using the TPS-MAP Blend feature because it defines a fixed amount of TPS to blend with the MAP sensor during a TPS failure.

### 11.3.2 Wiring the Check Engine Light

The check engine light output gives a pull-to-ground for a light bulb. Pin on the **TECgt200's** gray connector is the pink wire for the check engine light. The circuit should not be allowed to flow more than 0.25 Amps, which dictates that a light bulb of 3 Watts or less should be used. See **Figure 110** for wiring instructions.



**Figure 110:** Wiring diagram for the check engine output.

## 11.4 Tuning the Knock Control

Once an engine is tuned well enough to drive, the Knock Control feature can be used. The Knock Control retards timing based on detonation occurrence. When the detonation level detected by the **KNK** sensor exceeds the value defined in the Knock Threshold setting, the **TECgt200** will begin to retard the timing. More specifically, the timing will be retarded in increments defined by the Rate of Advance Retard. Each time a coil fires, the timing will be retarded by this amount until the knock level has dropped below the Knock Threshold. If the knock level drops below the Knock Threshold, the **TECgt200** will add back ignition advance in increments defined by the Rate of Advance Increase parameter. If the knock level does not drop below the Knock Threshold, the **TECgt200** will stop retarding the ignition timing when the Maximum Retard Allowed parameter is met. It is important to realize that the **TECgt200** will NEVER add ignition timing over and above the value set in the Ignition Advance Table when the Knock Control is adding advance back to the engine.

## 11.5 Using the Injector Trims

To compensate for fuel injector variations or cylinder-to-cylinder inconsistencies, advanced users of the **TECgt200** may wish to adjust the fuel delivery to individual injectors. The Fuel Trim feature allows these adjustments. When running in full-sequential injection mode, each individual injector can be trimmed. When running in phase-sequential mode, injectors can be trimmed in their driver channel pairs. TBI setups do not have a trimming option.

When the Fuel Trim function is used, a set percentage of fuel injector pulse width will be added or subtracted from each driver channel. Care should be taken not to lean the injectors out too much, since engine damage may result.

Fuel can be trimmed by + or – 15%.

## 11.6 Using the Ignition Advance Trims

Just as the fuel injector trims allow the fuel to be fine-tuned between cylinders, the Ignition Advance Trim feature allows timing to be adjusted based on coil output channels. When in phase-sequential operation, the coils can be trimmed in waste-spark pairs. When in full-sequential operation, the coils can be trimmed on an individual cylinder basis.

When the Ignition Advance trim is used, a set amount of timing can be added to or subtracted from the Ignition Advance curve. Certain engines have the tendency to detonate on certain cylinders more than others. To counteract this issue, the Ignition Advance Trim can be used to remove timing from the problematic cylinders.

Timing can be adjusted by + or – 15°.

## 11.7 Tuning the EGO Sensor

Tuning the EGO sensor is the final step in the engine tuning process. Since EGO sensors are only designed to provide a switch-point for stoichiometric operation, it is not recommended that the EGO be used in closed loop mode for anything other than its intended design: part throttle and idling stoichiometric control.

Start with tuning the EGO in closed-loop at idle. (Keep in mind that some exhaust configurations may not generate enough heat at idle to keep the sensor warm enough for repeatable readings.) With the engine running at the desired idle speed, lean the mixture out enough to detect a slight lean misfire. This can be done by manipulating the IOT/POT or the Volumetric Efficiency Table. The EGO reading will typically begin to sway back and forth erratically when misfiring is occurring. Richen the engine back up in small increments (1% VE adjustments, or 0.01 ms POT adjustments) until the misfiring is less noticeable. At this point, the EGO reading should come back in line. Record the EGO reading at this time, and enter this

value into the Air Fuel Ratio Table at cells surrounding (and including) the idle MAP/RPM point. Keep in mind that if the EGO is detecting an AFR around the stoichiometric point, the reading will be bouncing around slightly, but not nearly as erratically as when the engine is misfiring. If the EGO reading is still bouncing around, and richening up the mixture does not fix the problem, the EGO is too cold for closed-loop operation at idle.

When the idle is tuned in this manner, the engine will normally be running at its cleanest overall emissions. This will reflect a balance between HC, CO, and NO<sub>x</sub> production, and will keep the catalytic converter (if equipped) functioning properly. If an engine is running richer than stoichiometric, the NO<sub>x</sub> levels will fall, but the CO and HC levels will rise. Catalytic converters will become clogged with carbon deposits when this happens, and the exhaust gas temperatures will fall. When an engine is running leaner than stoichiometric, HC and CO levels will fall, but NO<sub>x</sub> levels will rise. Exhaust gas temperatures will rise, and catalytic converters will not be able to eliminate the high levels of NO<sub>x</sub>.

On a gas analyzer, high NO<sub>x</sub> production is indicative of an overly-lean mixture. High HC and CO levels are indicative of an overly-rich mixture. However, high HC levels with comparatively low CO levels will occur when the engine is misfiring. As such, high HC can sometimes be thought of as a misfire detector.

To use the EGO sensor at part-throttle, follow the same tuning procedure as was discussed for tuning the idle. Target the part-throttle cruise RPM and MAP points in the VE Table, and tune them to achieve an AFR of around 14.64. Once this is done, turn on the EGO sensor, and use the Desired Air Fuel Ratio Table to fine-tune your EGO correction value.

When using the EGO sensor, a **15% Authority Range** should be the maximum necessary for a properly tuned engine. An engine that requires more correction than 15% (in either direction) is not tuned properly to begin with.

Some tuners like to use the EGO sensor at higher engine loads. This is not necessarily a bad idea, but the limitations of an EGO sensor must be realized. As long as the Desired Air Fuel Ratio Table has appropriate values at the higher load points, it should not be too much of a problem. Keep in mind that high loads require richer mixtures. Most engines will detonate severely if a 14.64:1 AFR is used under high load. When tuning the EGO in this mode, it is best to start with extremely rich numbers in the AFR Table (like 11:1) to prevent lean-out problems.

## 12 Data logging with the TECgt200

There is a huge amount of data moving between the engine sensors and ECU when using the **TECgt200** system. The data logging feature of the system allows users to view all of this data in graphical format, thereby simplifying tuning and troubleshooting by a huge amount. Data logging is available in two modes : **On-Board** Data logging (OBD) and **PC-Based** Data logging (PCD). As their name imply, OBD stores sensor information inside the **TECgt200's** ECU, while PCD stores sensor information on the hard drive of a laptop.

### 12.1 PC-Based Data logging

PCD requires the use of a laptop computer to record sensor data. The volume of recorded data is only limited by hard drive space. Since the data is recorded in a simple text file, only a small amount of disk space is needed for a lot of data logging.

To engage the PCD function, simply click on the “Create Data log File” button in the WinTec software. The speed at which the data logging occurs can be defined, as can the length of the data recording. To view the data, click the “View Data log File” button in the software. The data can be displayed on either a single graph with all the sensors, or individual graphs for each sensor.

## 12.2 On-Board Data logging

On Board Datalogging, OBD does not require that a laptop be present to record data. Instead, the OBD function is engaged by a switch to +5 or +12 volts on a GPI channel. Using the Data Log Status Light line (pin [56]), an OBD status light can be wired to tell the user what mode of data logging is occurring. Consult **Wiring Sensors and Inputs** to wire the GPI and Data Log Status Light to configure the data logging. When wired appropriately, the status light will display the following codes : **Light is Off** : No OBD is occurring. **Light is Flashing** : The OBD function is active, and data is being recorded. **Light is On** : The OBD memory is full.

When the OBD memory is full, turn the GPI switch off. View the data log file with the Wintec software by selecting the GPI channel and double click on “Retrieve Data Log from Unit”. If you do not wish to view a particular OBD file, simply turn the GPI switch back on, and the previous file will be erased. This is an important fact : whenever the GPI switch is turned off, the data will remain in the Tec’s memory, even if the engine is shut off. When the switch is turned back on, the previous data will ALWAYS be erased.

There is the option to engage the OBD function only above a specified RPM point. When this is chosen, the OBD will be engaged when that RPM is reached, and will remain on until the switch is turned off, or the memory is full.

Typically, the RPM activation point is used for drag race applications in the following scenario : In the software, set the RPM point to be about 200 RPM above the staging RPM. Do the burnout and stage the car. Turn on the OBD feature. Make the run and turn the OBD off after crossing the finish line. Download the data to the laptop when you are ready to view it. The memory will be erased the next time the OBD switch is turned on.

The OBD has a much higher sampling rate than the PCD. The sampling rate can be defined in the software. Faster sampling rates allow less time to be viewed in a data log file. Conversely, slower sampling rates allow more time to be viewed in a data log file.

OBD total data logging time is limited by the memory space available in the Tec. When the data logging is operating at the highest frequency (20 samples-per-second), about 109 seconds of data can be stored in the memory.

## 13 Rev Limiters

Several different rev limiters are built into the **TECgt200** system. These rev limiters can be engaged in a few different manners, and can be used for a variety of functions.

### 13.1 Valet Mode Rev Limiter

The Valet Mode rev Limiter is engaged when the Valet Switch is turned on. See **Section Wiring General Purpose Inputs** for details on wiring the valet switch. Use a standard GPI input pin, a dash mounted switch and configure the function in Wintec. The Valet Mode Rev Limiter is activated by either RPM or Vehicle Speed. When the RPM or speed threshold is crossed, the Valet Mode Rev Limiter will be engaged.

Unlike the Primary and Secondary rev Limiters, the Valet Mode Rev Limiter only provides a fuel cut. The timing retard features will not be activated.

The Valet Mode Rev Limiter can also be used as a staging rev limiter in drag racing applications.

### **13.2 Secondary Rev Limiter :**

The Secondary Rev Limiter is activated when the MAT line (White 20awg, Pin 47) is connected to ground. When activated, it will engage the same type of rev limiter as the Primary Rev Limiter (so if the Three-Stage Rev Limiter is chosen for the Primary Rev Limiter, the Secondary Rev Limiter will also be a Three-Stage).

The Secondary Rev Limiter is most often used in drag racing applications as a staging rev limiter. A relay can be connected to the Trans-Brake on an automatic car, and when the brake is released, the relay will break the connection between the MAT line and ground.

The MAT reading will obviously drop to zero volts, which corresponds to a temperature of 150C. It is recommended that the Low Voltage Failure for the MAT be set slightly higher than zero volts to counteract this effect. This will cause the MAT reading to go to the Failure Default Value.

The easiest way to wire the Secondary Rev Limiter is to use a standard 4-position relay. Using the relay, Pins 30 and 87 will short to each other when 86 goes to +12 volts :

**Relay Pin 30** : MAT Sensor Signal (White 20awg, [47]) from the connector AND from the **TECgt200**.

**Relay Pin 87** : Sensor Ground (Black/White 18awg, [17]) from the MAT Connector AND from the **TECgt200**.

**Relay Pin 85** : Vehicle Ground

**Relay Pin 86** : Switch to +12 Volts to activate Secondary Rev Limiter.

### **13.3 Primary Rev Limiter :**

The Electromotive rev limiter is very flexible. For ignition control, the timing can be dropped to 0 degrees on rev limit, or our 3-stage coil cut can be used. Fuel control can also be controlled with either no fuel cut, a full fuel cut or the new progressive fuel cut. The options are described below.

#### **13.4 Zero degree advance**

This is the simplest rev limiter. When the rev limit is reached, timing is simply dropped to zero degrees. This item is unlikely to do the job by itself in any but the lowest power applications.

#### **13.5 3-stage coil cut**

The 3-stage coil cut uses three steps to limit RPMs. When the rev limit is reached, timing will drop to 12 degrees ATDC. This step by itself will cause a significant drop in power. However many high powered, boosted engines will continue to climb quite rapidly. After a specified number of RPM, the coil current is cut in half. This will cause the engine to misfire and further reduce the RPM increase. If the engine continues to climb, after the second specified number of RPM, the ignition is cut completely. This rev limiter alone will prevent over revving, but in the case of high powered drag engines coupled to an automatic transmission or supercharged applications, this can be quite violent. This is best used alone in naturally aspirated and turbo charged engines with a manual transmission.

#### **13.6 Full coil cut**

Full coil cut rev limiter turns all coils off at the rev limit speed.

## **13.7 FUEL CONTROL REV LIMITING**

### **13.7.1 No Fuel Cut**

This setting will never cut fuel. This option will typically only be used with the 3-stage rev limit.

### **13.7.2 Fuel Cut**

This setting will cut fuel completely on rev limit. This setting will typically only be used with the zero degree advance timing option.

### **13.7.3 Progressive Fuel Cut**

This option is the most powerful of all rev limit settings. Upon over revving, one injector event in 16 will be skipped. If the revs continue to rise, after the RPM delay and the time specified by the Update Rate, another injector event in 16 is skipped. This process will continue until all cylinders are cut or the revs drop below the RPM delay value. When the RPMs are above the rev limit and below the delay RPM, the number of cylinder events skipped will stay the same. If the revs drop below the rev limit and remain above the hysteresis value, the number of injector events will be increased. This will help to maintain a smooth consistent RPM when holding against the rev limiter.

# 14 Troubleshooting

Troubleshooting an engine management system is actually a fairly straightforward process. When viewed in simple terms, an engine that is in good mechanical condition, but will not run properly, can only need one of these things:

- Make sure there is adequate fuel pressure at all times.
- Make sure the crank trigger is installed properly.
- Make sure the wiring is correct.
- Make sure the DFUs are GROUNDED and that the coil screws are TIGHT.
- Make sure that the engine sensors are reading correctly.
- Make sure that the fuel injectors are firing, and are not clogged.
- Check the fuses and relays if a power loss occurs.

## 14.1.1 Air, Fuel, and Spark

As a result, troubleshooting an engine problem can be divided into these three parameters. With laptop software that allows the tuning of the engine as well as the diagnosis of potential engine sensor problems, troubleshooting an electronically controlled engine is fairly simple.

## 14.2 Starting Problems

### 14.2.1 Air-Related Starting Problems

- A small amount of air must enter the engine cranking in order for the engine to start.
  - Open the throttle a small amount during cranking. If the engine starts, manipulate the IAC motor settings as outlined in the **Tuning Guide Section sub section idle air control**. for proper start-up parameters.
  - If the engine does not start with a small amount of throttle opening, look to either fuel or spark-related problems.

### 14.2.2 Fuel-Related Starting Problems

**Note:** When diagnosing a fuel system problem, a fuel pressure gauge will be needed.

- With the ignition key switched on, the fuel pump should run for a few seconds. The fuel pressure should then increase to the rating of the fuel pressure regulator (typically 43psi).
  - If the pressure does not rise to this pressure, there is either air in the line, or the fuel pump or regulator is malfunctioning.
    - Air can be relieved from the fuel line by running the fuel pump for a minute or two.
  - If the pressure stays at 43psi but the engine will not start, look to the fuel injectors. With a stethoscope (or a screwdriver placed against the ear), listen to the fuel injectors while cranking the engine. A loud clicking sound should be heard. If none of the injectors are clicking, there is a wiring problem.
    - Check for +12volts on one injector terminal with the ignition turned on. If +12volts is present on one terminal, check the continuity between the other terminal and the injector channels of the **TECgt200**. If an oscilloscope is available, look for a +12 Volt square wave at the injector connector



- If the electrical test shows no problem, but the injectors are still not clicking, look to the injectors themselves. A stuck injector will not click. An injector that is stuck closed will not flow fuel, and an injector stuck open will flood a cylinder in short order.
- If the fuel system passes the above test procedure, look to the engine tuning calibration file.
  - Too much of a starting enrichment will flood the engine. A flooded engine will have spark plugs that are wet with fuel.
  - Too little starting enrichment will keep an engine from starting and running properly.
  - A coolant temperature enrichment that is too low or too high will cause an engine to have cold starting problems.

### 14.2.3 Spark-Related Starting Problems

- The crank sensor is the first thing to check when an engine will not start.
  - Crank the engine. The LED on the **TECgt200** ECU should flash red-green-red-green in a fairly steady fashion. If the light is not functioning in this manner during cranking, and there is no RPM reading when viewed on a laptop, there is likely a trigger problem.
  - IF the Crank indicator is solid green then...
    - Check the crank sensor alignment and air gap with the trigger wheel.
    - Check the crank sensor resistance (should be between 600 and 700 ohms across the red and black wires).
  - If the Crank indicator is solid red then...
    - check that all teeth are intact not damaged
    - The run out (out of round) of the sensor wheel is not excessive.
    - No other electrical interference is present such as DC motors or spark plug wires are near the sensor or wheel.
    - That the steel wheel and pulleys are not magnetized
  - If the LED is functioning normally, check for spark at the coils. Remove the two spark plug wires from the coils, and watch for a spark between the coil towers during cranking. **BE EXTREMELY CAREFUL NOT TO TOUCH THE SPARK!!** It will really be painful, and can be deadly to people with pacemakers!
    - If there is no spark, check the wiring to the DFU and to the **TECgt200**. Pin D on the DFU should have +12volts with the ignition key on.
    - If the wiring is good, and the coils are still not firing, look to the software. Make sure the appropriate calibration file is loaded.
    - If there is spark across the coil towers, but the engine will not run, check the plugs and plug wires. Also be sure that the coils are firing the appropriate cylinders (see **Wiring section, sub section coil firing patterns**). An engine will not run (or will run very rough) if the plug wires are not going to the appropriate cylinders.
- If the engine backfires through the throttle, check that “mechanical timing” has not been added or subtracted with an improper trigger wheel installation.

### 14.3 Idling Problems

**Sections on Idle speed control in the Tuning Guide** above should be consulted to determine problems with idling that are tuning-related before any troubleshooting is undertaken.

### 14.3.1 Air-Related Idling Problems

- If using an IAC motor, and the engine is surging at idle, turn the IAC control OFF.
  - If the engine idles nicely, it is likely an IAC tuning problem.
  - If the engine still surges, it is likely an air-fuel mixture problem.
- If using an IAC motor and the engine runs rough at idle, it is likely an air-fuel mixture problem.
- If the IAC motor does not seem to be functioning at all, check the TPS closed throttle voltage. This value must be ABOVE the actual TPS reading at closed throttle in order for the IAC motor to be engaged.
- If the engine idles too high, either the IAC motor is not functioning, the RPM value set in the calibration file is too high, or the throttle plate is opened too far.
- To check for proper IAC functioning, the pintle should retract fully when the ignition key is first turned on, if using a 4-wire IAC motor. The motor should then move out by the specified amount in the IAC motor settings.

### 14.3.2 Fuel-Related Idling Problems

- Check for stuck injectors and fuel pressure problems if the idling characteristics cannot be improved through tuning see the **Section on Fuel Injection** sub section Fuel Related Starting Problems to see if the fuel injectors are functioning properly.
- If the engine is blowing black smoke out the exhaust during idling, the mixture is too rich. Decrease the IOT, or decrease the VE Table values at the problem area.
- If the engine misfires at idle, the mixture is probably too lean. Increase the IOT, or increase the VE Table values at the problem area.

### 14.3.3 Spark-Related Idling Problems

- Check for wiring problems before attempting to correct an idling problem. If the plug wires are run correctly, and the DFUs are powered correctly, check the ignition advance table.
- Engines typically need at least 10° of timing to idle smoothly. Check the Timing Advance Table at the idle MAP/RPM points.
- Check the trigger wheel installation to make sure that “mechanical” timing has not been (unknowingly) added or subtracted.

## 14.4 Low-, Medium-, and High-Load Problems

### 14.4.1 Air-Related Load Problems

To function properly, the only air-related load problems arise from improperly sized throttles. Make sure that a throttle can flow enough air for an engine. Stock throttles on heavily modified engines will typically cause upper-rpm performance problems.

### 14.4.2 Fuel-Related Load Problems

- Fuel problems when an engine is under load can cause engine damage quickly. The first check for the fuel system is to look at the fuel pressure.
  - If the fuel pressure is dropping with load, there is a problem. Either the fuel pump cannot keep up with the engine’s fuel needs, or the fuel pressure regulator is not functioning properly. Fuel pressure should increase by 1psi with every 1psi of boost on turbo- or supercharged engines (unless a rising rate regulator is installed).
  - If the fuel pressure is good, the injectors may be undersized. Go through **Section called Fuel System Sizing** to determine if injector sizing is a problem.

- If the injectors are sized appropriately and the fuel pressure is adequate, it is likely a tuning issue. Consult **Section called Tuning Guide**.
- Undesired EGO sensor corrections can contribute to fuel problems under load. Consult **Section Fuel Injection / Oxygen Sensor Corrections** for EGO tuning recommendations.

### 14.4.3 Spark-Related Load Problems

- Problems related to spark when under load can be traced to three factors: Tuning, Secondary Ignition Failure, and Improper Wiring. Make sure the DFU's are wired correctly before proceeding.
  - Tuning issues sometimes seem like spark-related problems. An engine that is detonating has too much timing in the Ignition Advance Table, or is not receiving enough fuel. An engine that is not performing well may have too little timing, or too much timing.
    - Try adding timing until detonation is detected, then back off a bit. Rotary engines do not make a loud pinging sound, so **do not** attempt to run a rotary into detonation.
  - Secondary Ignition failure is often blamed for ignition problems under load. The secondary ignition includes the spark plugs and spark plug wires. **See the Wiring Section** above for the proper selection of spark plugs and wires.
    - Make sure the coil screws are very tight! Also, the DFU's must be grounded for proper operation.
    - If misfiring occurs under load, loose coil screws or ungrounded DFUs are often the culprit.

# 15 Appendix I. ECU Specifications

## 15.1 OUTPUTS

### 15.1.1 Fuel Injector Drivers

- 6 x 3 amp saturated switch injector drivers
- Up to 12 high impedance injectors can be driven

### 15.1.2 Coil Outputs

- 6 x 8 amp direct-fire coil drivers
- Feedback charging loop for ideal cylinder-to-cylinder consistency
- No “ignition modules” or “CD” boxes needed
- 6 parallel Logic output for DOC coils, with user set fixed dwell time.

### 15.1.3 Idle Air Control (IAC) Motor

- Provides control of 4-wire stepper motor IAC’s
- 2-wire IAC motor control
- Adjustable idle speed increase for cold starts
- Adjusts idle speed in response to engine load (i.e. A/C activation)

### 15.1.4 General Purpose s (GPO’s)

- 1 amp max per GPO channel
- 9 channels of pull down outputs
- 4 channels are push-pull for 4 wire IAC’s

### 15.1.5 Fuel Pump Control

- Low current pull-to-ground output for activation of fuel pump relay
- Configurable for fuel system priming

### 15.1.6 Tachometer Output

- Drives modern 0-12 volt tachometers
- High side amplifier to drive multiple triggered tachometers and other devices.

### 15.1.7 Check Engine Light Output

- Pull-to-ground output for instrument panel light (1 amp max current draw)

### 15.1.8 ECU Diagnostic Check engine Lamp

- Warns of crank trigger problems
- Multi-code diagnostics

## 15.2 INPUTS

### 15.2.1 General Purpose Inputs (GPI’s)

- 8 channels 0-5 Volt analog inputs
- 1 Resistive temperature device.
- 1 Secondary EGO channel 0-5 Volts
- 1 Road Speed pulse input

### 15.2.2 Engine Sensor Inputs

- Crank Sensor
  - 2-wire magnetic or Hall sensor (compatible w/ some OEM’s)
  - Uses Electromotive-spec 60(-2) tooth crank trigger
  - Ultra-high resolution engine position input
- Cam Sensor

- Hall effect sensor necessary for full-sequential applications
- Once-per-cam-revolution pulse
- Manifold Air Pressure (MAP) Sensor
  - 1 Bar: 0-104kPa absolute  
30”Hg – 0”Hg (naturally aspirated)
  - 2 Bar: 0-206kPa absolute (up to 1 Bar Boost)  
30”Hg – 15psi (up to 15 psi Boost)
  - 3 Bar: 0-313kPa absolute (up to 2 Bar Boost)  
30”Hg – 30psi (up to 30psi Boost)
- Throttle Position Sensor (TPS)
  - Uses throttle shaft-mounted rotary potentiometer
  - Compatible with most OEM 3-wire setups
- Coolant Temperature Sensor (CLT)
  - Uses NTC thermistor coolant sensor (2-wire)
- Manifold Air Temperature Sensor (MAT)
  - Uses NTC thermistor manifold temperature sensor (2-wire)
- Knock Sensor (KNK)
  - Provides ability to detect pre-ignition
  - Compatible with piezo-style knock sensors (1-wire)
- Oxygen Sensor (EGO)
  - Compatible with 1-, 3-, and 4-wire oxygen sensors
  - Wide Band converter modules (0-5v output)

### 15.2.3 Angle Based Timing Control

- Ultra-high resolution triggering
- Engine position known to within 1/8°

### 15.2.4 Feedback Charging Control

- Monitors each coil firing event
- Coil current monitoring
  - Consistent dwell adjustment
  - Full coil charging without overcharging

## 15.3 Tuning Features

### 15.3.1 Ignition Timing Map

- 16 x 16 user definable tables of RPM vs. MAP for ignition advance angle
- 65535-point interpolation between data points
- 1° adjustment increments
- +/-1/4° spark timing accuracy, worst case

### 15.3.2 Fuel Map

- Two numbers define slope of fuel curve
- 16 x 16 tables of RPM vs. MAP for volumetric efficiency corrections
- 65535-point interpolation between data points
- 1% adjustment increments (up to 0.001millisecond resolution)

### 15.3.3 Load Sensing – Three Options

- MAP sensor based
- TPS & MAP based (using ‘TPS/MAP Blend’ feature)
- TPS Based (using 100% TPS/MAP Blend)

### 15.3.4 Rev Limiters

- Progressive “soft” rev limiter (3 stages)

- Fuel injector cutoff
- 1000-2000rpm capability for primary rev limiter
- 1500-12000rpm capability for auxiliary rev limiter

### 15.3.5 On-Fly Tuning

- Glitch-free, real-time tuning while engine is running
- Full control of all fuel, ignition, and input/output parameters

### 15.3.6 Compensation Features

- Fuel
  - Individual cylinder fuel trims
  - Oxygen sensor closed loop corrections
  - Starting (cranking) enrichments
  - Cold start / cold weather enrichments
  - Accelerator pump enrichments
  - Deceleration fuel cutoff
  - Battery voltage correction for injector pulse widths
- Ignition
  - Coolant temperature-based advance adjustments
  - Manifold air temperature-based advance adjustments
  - Smooth idle advance control (integrated w/ IAC settings)
  - Paired-cylinder timing trims (each coil has timing trim)
  - Individual-cylinder timing trims for full-sequential setups
  - Ignition timing offsets for odd-fire applications
  - RPM-based timing split for rotary application

## 1.1 Supported Engine Configurations

### 15.3.7 4-Stroke

- 1-, 2-, 3-, 4-, 6-, 8- 12- cylinder even-fire engines.
- 2-, 4- 6- cylinder odd-fire engines.
- 2-, 4- 6-cylinder dual-plug engines.
- Full sequential fuel injection on all even-fire applications (**except 8,12 cyl.**)
- Phase-sequential and TBI injection on all applications
- Staged injection available for most setups
- Waste-spark ignition control for all applications

### 15.3.8 2-Stroke

- 1-, 2-, 3-, 4- cylinder engines.
- Full sequential fuel injection or TBI
- Staged injection available for all setups
- Coil-per-plug for all applications

### 15.3.9 Rotary

- 1-, 2- 3-rotor engines.
- Full sequential fuel injection w/ staged injection or TBI
- Coil-per-plug for all applications

## 15.4 Data logging Features

### 15.4.1 Laptop Data logging

- Records to hard drive on laptop

- Sampling rate is approximately 50 samples-per-second
- Total data logging time is limited only by hard drive space

## 15.5 Physical Dimensions

Length:	7.5"
Width:	4.0"
Height:	1.0" (add for connector)
Weight:	1.55 lbs
Bolt Hole Pattern:	6.88" x 3.375" (1/4" – 6mm bolts)

## 15.6 Environmental Considerations

One Sealed 73-Pin Molex MX123 Connector for Inputs & Outputs  
Sealed Printed Circuit Board. Water resistant case, under hood mountable.

## 15.7 PC Requirements

### Computer

- IBM-Compatible PC
- Pentium-1 233 or better
- 1024 x 768 monitor resolution (256 colors)
- 64 Mb of ram
- 10 MB of free hard drive space

### Communications

- RS-232 9- or 25-pin D connector
- COM 1-99 (software selectable)
- USB Optional, use either or RS232 or USB but not both
- CAN Bus Data Output

# 16 Appendix II. Trigger Wheel Availability

## Universal 60(-2) Tooth Crank Trigger Wheels – All Have 1" Center Hole (unless noted)

8.25" Outer Diameter	PN 230-72682
7.25" Outer Diameter	PN 230-72672
6" Outer Diameter	PN 230-72660
5" Outer Diameter	PN 230-72650
3.5" Outer Diameter	PN 230-72635
2.5" OD, 1.5" Center Hole	PN 230-72625
2.375" OD, 0.25" center Hole	PN 230-72624

## Universal 120(-4) Tooth Wheels Cam Trigger Wheels

2.75" Outer Diameter	PN 230-72128
3.25" Outer Diameter	PN 230-72133

**Custom Bolt-On Trigger Wheel Kits** – All custom kits include everything necessary to install a trigger setup. Kits with a 220- Part Number reuse the stock sensor and mount in the stock location. Kits with 205- designations use the 3/8" sensors, while 200- kits use the 1/2" sensors.

Chevrolet Small Block – 8" Damper	PN 200-72808
Chevrolet Small Block – All Other Dampers	PN 200-72707
Chevrolet LT1	PN 205-72828

Chevrolet Big Block – all Dampers	PN 200-72820
Ford Small Block – 351W Based Engines	PN 200-72819
Ford 4.6L & 5.4L SOHC and DOHC	PN 220-72500
Toyota Supra 3.0L 2JZ-GE & GTE (1993-1998) (includes current Lexus IS300)	PN 220-72301
Eclipse/Talon 2.0L (1 <sup>st</sup> Generation only)	PN 200-73002
Honda 'B' Series DOHC VTEC (No P/S or A/C)	PN 200-72410
Dodge Neon (1 <sup>st</sup> generation SOHC & DOHC)	PN 200-73001
VW Type 1	PN 200-72401
Jeep 4.2 Liter	PN 205-72780
2 <sup>nd</sup> Generation MR2 Turbo & NA	Coming Soon

Please note that most common engines have trigger kits made by our various dealers. Porsche, Mazda, Toyota, Acura/Honda and Subaru applications are currently covered extensively.



# 17 Appendix III. Secondary Coil Polarity for Redundant Ignition Applications

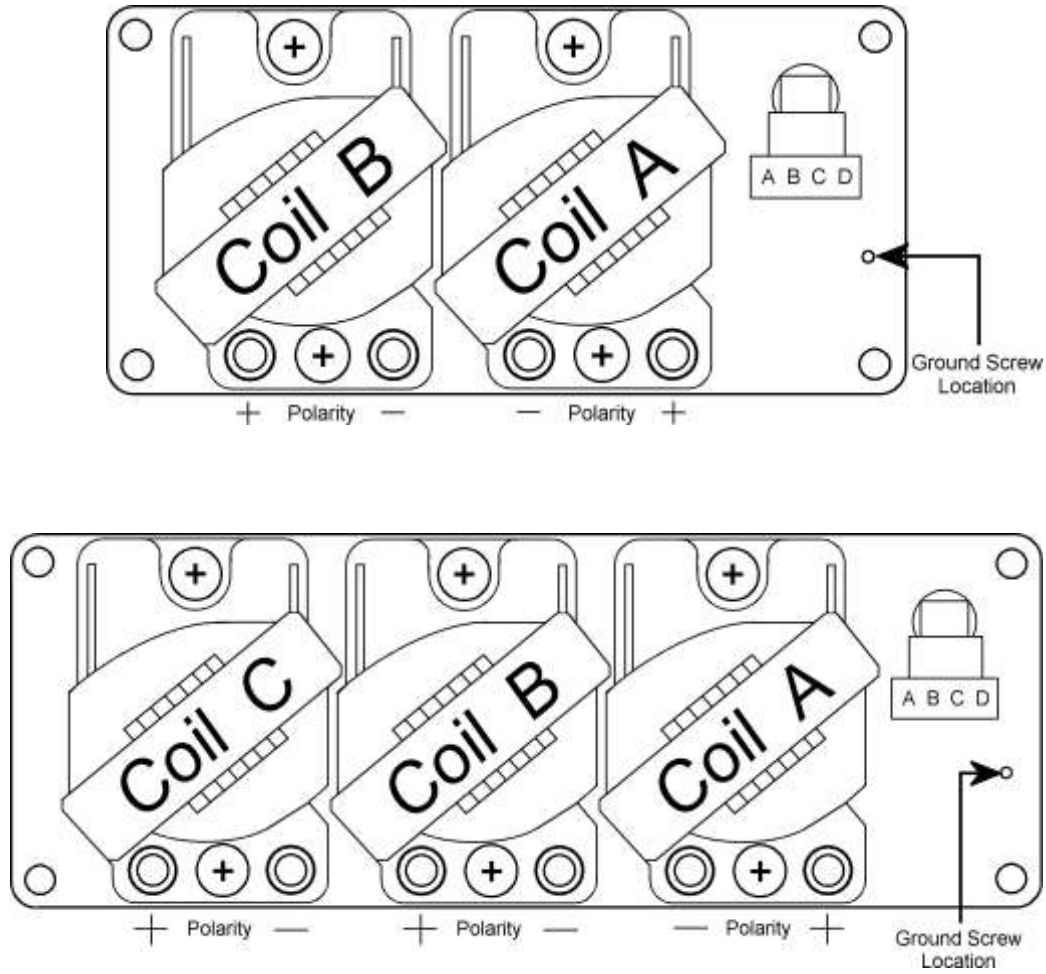


Figure 120: DFU Secondary Voltage Polarity – for Redundant Ignition Applications.

## 18 Software & Firmware Support

The **TECgt200** is designed to be fully upgradeable with respect to its software and firmware. The software is the operating system that is used to tune the engine. The firmware is the embedded code that is installed in the **TECgt200's** processors. Small changes in functionality can be covered with software changes. Larger changes in functionality, particularly the addition of new features, generally require a firmware upgrade.

Both software and firmware upgrades are available for a nominal fee on our website. To perform the upgrade (that is, to purchase software and firmware upgrades), you will need to know your unit's serial number. **Software and Firmware upgrades that are purchased with a serial number that does not match your unit's serial number WILL NOT WORK on your unit.**

### 18.1.1 Software Coding Information

Electromotive calls its **TECgt200** Windows software "WinTec 4.X.Y." The "4.X.Y" portion of the WinTec name is the code that is used to tell what the version of software is made for.

- The "4" means simply the software version 4 platform.
- The "X" digit states the FIRMWARE version on which the software will function.
- The "Y" digit states the latest build SOFTWARE version.

The software version is displayed when the WinTec software is opened on a computer. Software versions are compatible with the firmware version for which they are designed. For example,

- A 4.0.3 software version is compatible with a 4.0.0 firmware version.
- A 4.1.2 software version is compatible with a 4.1.0 firmware version.
- A 4.1.0 software version WILL NOT run with a 4.0.0 firmware version.

**Always use the PC SOFTWARE version for which the FIRMWARE is designed. The "X" digit of the PC software must always match the "X" digit of the Firmware!**

### 18.1.2 Firmware Coding Information

The Firmware version is displayed in the Engine Monitor Screen. The firmware code is "4.X.0.T3" The "X" digit must match the "X" digit of the software version (see above). This is the firmware version. Firmware for the **TECgt200** starts with "WTL02". The next two digits XX are the release version, release changes, new feature additions or some other major change will be signified in this number. The last 3 digits are the build number. Build number YYY indicates bug fixes from one release level to the next. Example : where firmware file number "WTL02xxyyy" XX is the release number, YYY is the build number.

### 18.1.3 Software Upgrade Procedure

As was previously stated, the firmware and software versions are completely upgradeable through a simple software download from the Electromotive website. Software upgrades are simple, and can be accomplished with the following steps.

1. Download the software from the Electromotive website onto a PC.
2. Install the new WinTec software onto the PC that you will use for tuning your engine.
3. Open the NEW WinTec software version on the PC, and open the OLD calibration file (the \*.bin file) into the NEW WinTec software.

4. The main values from your old \*.bin file should be transferred directly. However, for safety, ALWAYS make sure that the old \*.bin values are the same as the new values.
5. Save the bin file in the new WinTec software version (give it a new name).
6. Download the new file into your **TECgt200** ECU as you normally would.

Following this step-by-step procedure should keep everything straightforward during the upgrade process.

#### **18.1.4 Firmware Upgrade Procedure**

Care must be taken when installing different firmware versions on your **TECgt200** ECU. Follow the steps outlined below:

1. Download the Firmware upgrade from the Electromotive website.
2. Install the firmware upgrade on the PC that you will use to tune the engine.
3. Connect the **TECgt200** to the PC's serial or USB port and power it ON.
4. Startup the WinTec software, it should show in the System console that the unit was found and display the firmware version.
5. Turn-OFF power to the TEC unit.
6. Turn on power to TEC but do not run engine
7. Go to Tools > Options > Firmware Upgrade. Find and select the new .em3 file and download
8. Once the upgrade is complete, cycle the power to the TEC. If the firmware upgrade was successful, both LED's will go GREEN. If the firmware upgrade failed, the ECCL LED will stay RED and the crank will stay off. If this occurs, start the procedure over at step 5.
9. The firmware is now upgraded, you can begin/continue tuning.

## 19 Appendix IV. ECU Connector Pin Out List

Pin	EMI Color	Gauge	Function	Alternate Color	Assigned Function
1	Bare (A)	16 TST	Coil Shield		
2	White(A)	16 TST	Coil A1		
3	Red(A)	16 TST	Coil B1		
4	Black(A)	16 TST	Coil C1		
5	Blk/Gray	20TXL	DoC A1		
6	Blk/Red	20TXL	DoC B1		
7	Blk/Grn	20TXL	DoC C1		
8	Tan	20TXL	Ground		
9	Orange	20TXL	Knock		
10	Blk/Blue	20TXL	DoC A2		
11	Blk/Pink	20TXL	DoC B2		
12	Blk/Org	20TXL	DoC C2		
13	Bare (B)	16 TST	Coil Shield		
14	White(B)	16 TST	Coil A2		
15	Red(B)	16 TST	Coil B2		
16	Black(B)	16 TST	Coil C2		
17	Blk/Wht	20TXL	Ground		
18	Blk/Wht	20TXL	Ground		
19	Gray/Red	20TXL	5V Ref		
20	Gray/Red	20TXL	5V Ref		
21	Gray/Red	20TXL	5V Ref		
22	Org/Red	20TXL	GPI2		
23	Org/Grn	20TXL	GPI3		
24	Org/Blue	20TXL	GPI4		
25	Org/Ppl	20TXL	GPI5		
26	Org/Pink	20TXL	GPI6		
27	Org/Tan	20TXL	GPI7		
28	Org/Yel	20TXL	GPI8		
29	Org/Gray	20TXL	GPI9		
30	Brown	7cond	Ground		
31	Orange	7cond	RXD		
32	Blue	7cond	TXD		
33	Red/Wht	18TXL	12 volt in		
34	Org/Blk	20TXL	Speed In		
35	Black/Shield	7cond	USB GND		
36	Red	7cond	USB PC5V		
37	White	7cond	USB D-		
38	Green	7cond	USB D+		
39	Yel	20TXL	CAM in		

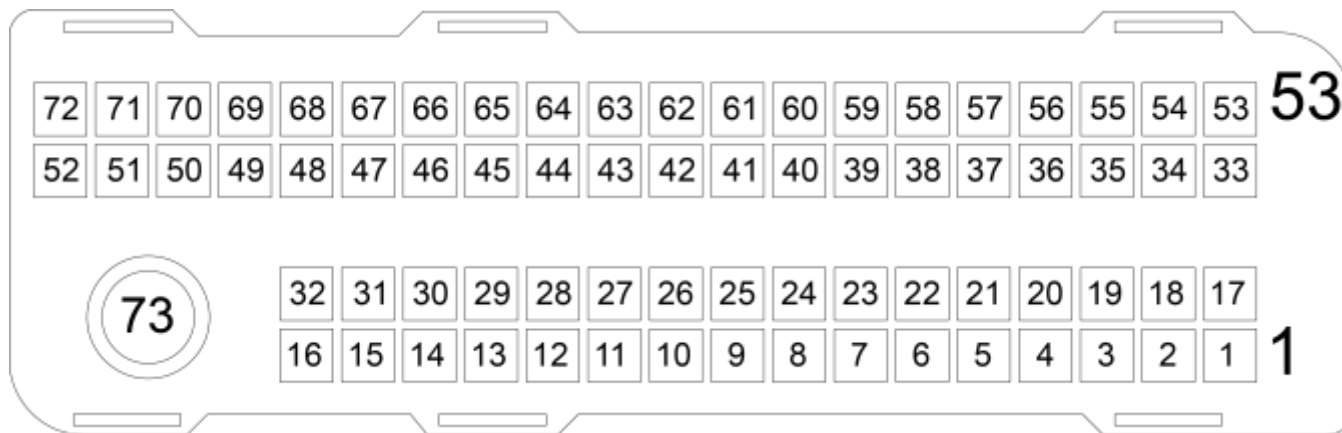
40	Yel/Ppl		CAM 2		
41	Black/Wht	20TXL	Ground		
42	Red	24 TSP	Crank Sensor in		
43	Blk/Shld	24 TSP	Ground		
44	Green	20TXL	MAP		
45	Blue	20TXL	TPS		
46	Gray	20TXL	CLT		
47	White	20TXL	MAT		
48	Org/Wht		EG RTD		
49	Purple	20TXL	EGO Primary		
50	Ppl/Tan		EGO Secondary		
51	Yel/Pink	20TXL	CAN H		
52	Grn/Pink	20TXL	CAN L		
53	Red/Wht	18TXL	12 volt in		
54	Wht/Grn		GPO 7		
55	Wht/Red		GPO 2		
56	Wht/Org		Data log stat		
57	L.Grn	20TXL	FPR		
58	White/Blk	20TXL	GPO1		
59	Pink	20TXL	CE		
60	D.Blu/Wht	20	IACB / GPO4		
61	D.Blu/Blk	20	IACA / GPO3		
62	Brown	20TXL	Tach		
63	Wht/Ppl		GPO9/VVT		
64	Wht/Blue		GPO8/VVT		
65	D.Grn/Wht	20	IACD / GPO6		
66	D.Grn/Blk	20	IACC / GPO5		
67	Yel/Blk	20TXL	Inj1		
68	Yel/Red	20TXL	Inj2		
69	Yel/Grn	20TXL	Inj3		
70	Yel/Blue	20TXL	Inj4		
71	L.Blue/Blk	20TXL	Inj5		
72	L.Blue/Red	20TXL	Inj6		
73	Black	12TXL	Main Gnd		

## 20 Appendix V. ECU Connector Drawing

Please go to this internet link and down load this document:

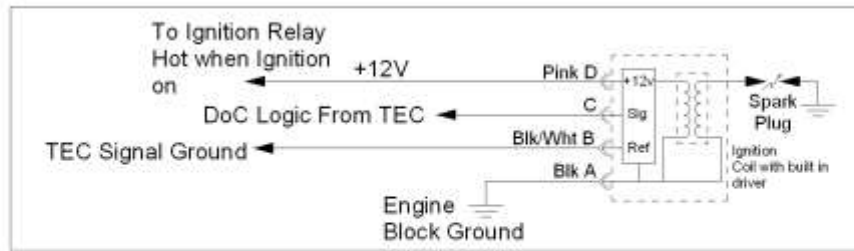
[http://www.molex.com/pdm\\_docs/as/AS-34566-001.pdf](http://www.molex.com/pdm_docs/as/AS-34566-001.pdf)

It has important information on handling the TECgt200's new Molex connector.

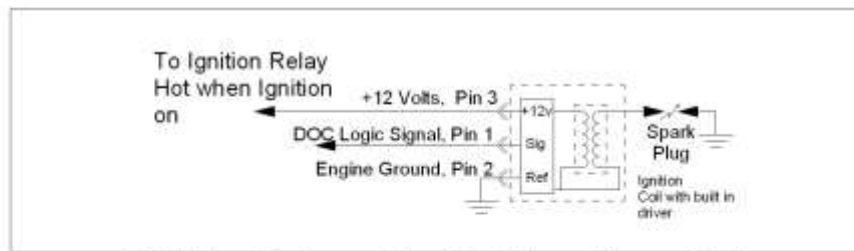


**Molex 73 Circuit MX123  
Wire Side Shown**

## 21 Appendix VII. Driver on Coil Schematic



**4 Wire Driver On Coil Ignition Coil  
(Example shown is GM LS coil)**



**3 Wire Driver On Coil Ignition Coil  
(Example shown is Hitachi, Honda coil)**

TECgt200 Pin	Function	Wire Color	4 Cylinder	6 Cylinder	8 Cylinder
		Firing Order	1,3,4,2	1,5,3,6,2,4	1,8,4,3,6,5,7,2
17	ECU Ground	Blk/Wht			
5	DoC A1	Blk/Gray	1 & 4	1 & 6	1 & 6
6	DoC B1	Blk/Red	2 & 3	5 & 2	4 & 7
7	DoC C1	Blk/Grn		3 & 4	
17	ECU Ground	Blk/Wht			
10	DoC A2	Blk/Blue			5 & 8
11	DoC B2	Blk/Pink			2 & 3
12	DoC C2	Blk/Org			

**Wiring of TECgt200 Driver on Coil Logic outputs to Cylinder Coils**

## 22 Glossary of Terms

**Advance:** As applied to ignition timing, advancing the timing refers to firing the spark plug comparatively sooner.

**ATDC (After Top Dead Center):** When a piston is moving downward, after TDC.

**Bar:** A Bar is a measurement of pressure. One Bar equals 101.3kPa or 14.7psi. Standard atmospheric pressure is 1-Bar absolute, or 0-Bar relative (gauge). An engine running 1-Bar of turbo boost is actually running 2-Bar absolute, so it requires a 2-Bar MAP sensor.

**Boost:** When a pressure that is greater than the ambient atmospheric pressure is forced into the intake manifold. Turbo- and superchargers create boost.

**BTDC (Before Top Dead Center):** When a piston is moving upward, but has not yet reached TDC.

**Cam Sensor:** A device used to provide a once-per-engine cycle pulse to the **TECgt200**. This establishes the stage of engine operation that is occurring for a given TDC.

**Closed Loop:** When an oxygen sensor reading is used to correct the air-fuel mixture through the manipulation of the fuel injector pulse widths.

**Coolant Enrichment:** A coolant temperature-based fuel enrichment that is used to add fuel when an engine is cold. This feature is the electrical equivalent of the choke plate on a carburetor.

**Coolant Temperature Sensor:** A device that measures the coolant temperature of an engine.

**Crank Sensor:** A device that can “read” a crank trigger wheel, and output a voltage signal that can be used by an engine management system.

**Crank Trigger:** A device used to measure the crankshaft position and speed, typically composed of a crank trigger wheel and a crank sensor.

**Detonation:** When the air-fuel mixture is ignited by the spark plug, then a high cylinder temperature “spontaneously” ignites another portion of the unburned mixture. A knocking sound is produced when detonation occurs, and knock sensors are designed to hear this knocking. Engine damage can be caused by detonation.

**DFU:** Direct Fire Unit. Electromotive coil packs are referred to as DFUs.

**Duty Cycle:** The percentage of time that a pulse width modulated output is turned on. A duty cycle of 100% indicates a fully turned-on modulation output.

**ECU:** Electronic Control Unit. A device that is used to process several inputs for the control of several outputs.



**Exhaust Gas Oxygen (EGO) Sensor:** A device that compares the oxygen content of the exhaust gases with the oxygen content of the ambient atmosphere. An air-fuel ratio approximation can be made with an EGO sensor.

**Enrichment:** A software parameter that adds injector pulse width (typically as a percentage) to the values defined by the raw fuel curve.

**Fuel Pressure Regulator:** A device that regulates the fuel rail (and thus the fuel injector) pressure. Generally equipped with a vacuum port referenced to manifold vacuum/boost to adjust fuel pressure on a 1-to-1 basis with manifold pressure. For examples, a regulator will increase fuel pressure by 1psi for every psi increase in manifold pressure.

**Gamma:** See TFPW. This number is no longer used with **TECgt200** systems.

**General Purpose Inputs (GPI):** Input channels that the **TECgt200** can use to process data from sensors that are not related to the core engine management sensors. Switches and vehicle speed sensors can be run to the GPIs.

**General Purpose Outputs (GPO):** Output channels from the **TECgt200** that can be used to trigger external devices such as thermo fans, torque converters, etc.

**Horsepower (HP):** A measurement of the rate at which an engine can perform work. One HP = 550 lb-ft per second.

**Idle Air Control (IAC) Motor:** A device that is used to meter air into an engine at idle. Air from the outside of the intake manifold is regulated into the intake plenum by the IAC motor.

**Ignition Timing:** The amount of degrees before Top Dead Center that a spark plug fires.

**IOT/POT:** Injector Offset Time. (a.k.a. Pulse-width offset time) This number adds or subtracts a fixed pulse width from the raw fuel curve. The value of IOT/POT is the amount of time (in milliseconds) that will be added or subtracted.

**Knock Sensor:** A device used to measure detonation.

**Knocking:** see 'Detonation'

**Lean Mixture:** An air-fuel mixture that carries less fuel than the stoichiometric air-fuel ratio.

**Load:** The amount of work that an engine must provide at a given instant. Load is measured by using the MAP sensor to estimate the cylinder pressure on **TECgt200** systems. Higher loads result in higher MAP readings.

**Manifold Air Pressure (MAP) Sensor:** A device that measures the absolute pressure of the intake charge for an engine.

**Manifold Air Temperature Enrichment:** An inlet air temperature-based enrichment that is used to add fuel when the incoming air is cold, and therefore denser than usual.

**Manifold Air Temperature (MAT) Sensor:** A device that measures the temperature of the incoming air charge for an engine.

**Millisecond (ms):** A length of time equal to one one-thousandth of a second.  
1 millisecond = 0.001 second

**Mixture:** A term used to describe the air and fuel entering the engine as a single entity.

**Multi-Port Injection:** The most common form of modern fuel injection, whereby each cylinder has its own fuel injector.

**Open Loop:** When an engine is running off of its base calibration with no EGO sensor feedback to correct the air-fuel ratio.

**Pinging:** See 'Detonation'.

**POT/IOT:** Pulse Width Offset Time (a.k.a. Injector Offset Time). This number adds or subtracts a fixed pulse width from the raw fuel curve. The value of POT/IOT is the amount of time (in milliseconds) that will be added or subtracted.

**Pre-Ignition:** When the air-fuel mixture is ignited by a hot spot in the combustion chamber BEFORE the spark plug fires. When pre-ignition occurs, it produces a similar effect to advancing the ignition timing too much. Engine damage may result.

**Pulse Width:** The amount time that an injector is turned on for a given operating scenario. Expressed in milliseconds (ms).

**Pulse Width Modulation (PWM):** When a variable pulsed voltage signal is supplied to a module, pulse width modulation is occurring. Fuel injectors are common examples of PWM-controlled modules.

**Stoichiometric Mixture:** An air-fuel mixture that has the chemically ideal ratio between incoming air and fuel. When combusted, the product of a stoichiometric mixture will carry no excess air or fuel.

**Retard:** As applied to ignition timing, retarding the timing refers to firing the spark plug comparatively later.

**Rich Mixture:** An air-fuel mixture that carries more fuel than the stoichiometric air-fuel ratio.

**Rising Rate Fuel Pressure Regulator:** A Fuel Pressure Regulator that is adjustable to provide a non 1-to-1 relationship between manifold pressure and fuel pressure. For example, a rising rate regulator may be used to supply 2psi of fuel pressure increase with every 1psi of manifold boost.

**Spark Knock:** See 'Detonation'

**TDC (Top Dead Center):** On piston engines, when a piston is at its highest point (closest to the cylinder head), and the combustion chamber is at its smallest volume, it is at TDC. TDC#1 refers to the case when the #1 cylinder is on TDC. On rotary engines, TDC occurs when the combustion chamber volume is smallest.

**TFPW:** Total Fuel Injector Pulse Width. This number defines that total modification to the raw fuel curve that is occurring at a given instant. A TFPW of 100% indicates that no modification is occurring to the raw fuel curve. A TFPW less than 100% indicates a leaner pulse width than the raw fuel curve value, while a TFPW greater than 100% indicates a mixture that is richer than the raw fuel curve value.

**Throttle Position Sensor (TPS):** A device used to measure the position of the throttle.

**TOG/UAP:** Time on for one Gama (a.k.a. User Adjustable Pulse Width) This number defines the slope of the raw fuel curve. When TOG/UAP is zero, the raw fuel curve will have zero pulse width at zero MAP sensor volts. When the MAP sensor is at +5 volts, the pulse width will be the number defined by TOG/UAP expressed in milliseconds.

**Torque (TQ):** A measurement of the work that an engine can perform, typically expressed in pound-feet (lb-ft).

**TPS/MAP Blend:** A feature of the WinTec software that allows the TPS and MAP sensor readings to be blended together. Typically, this feature is used on engines with radical cams or throttle-per-cylinder setups since these engines have poor MAP signals at idle and part throttle.

**Trigger Wheel:** A device attached to the crankshaft that provides a moving reference of speed and position of an engine's crankshaft.

**UAP/TOG:** User Adjustable Pulse Width (a.k.a. Time on for One Gama). This number defines the slope of the raw fuel curve. When UAP/TOG is zero, the raw fuel curve will have zero pulse width at zero MAP sensor volts. When the MAP sensor is at +5volts, the pulse width will be the number defined by UAP/TOG, expressed in milliseconds.